



Operators Manual

**** MAC JR 1200E ****

USE IN CONJUNCTION WITH M2-E922 MIXER MANUAL (ENCLOSED)

Unit Serial No. _____

M2-E922 Mixer

Serial No. _____

Links relating to this Manual

www.stsmixers.com

Dealer

TABLE OF CONTENTS

	PAGE
STS Inc. Warranty.....	5
Safety Statements.....	6-9
Safety Markings.....	10
Main Working Components (<i>Photo</i>).....	11
Introduction to the MAC JR 1200E	12
MAC JR 1200E Foot Print (<i>top view</i>).....	13
MAC JR 1200E General Data Sheet	14-15
Identifying Your Machine & Components	16
 <u>SECTION II</u> (<i>Description, Care and Maintenance</i>)	
Base Skid with Tanks	18-20
Internal Tank Nozzles	21
External Piping	22
Leveling Jacks	23
2 Cone Head Assembly	24
Cone Manifold	25
Hydro-Cyclones	26
Over-Flow Box	27
Under-Flow Box	28
Valves on the M2-922 Mixer	29

TABLE OF CONTENTS

	PAGE
<u>SECTION III</u> (<i>Set-up and Connection of unit in Detail</i>)	
Site Set-up (work mode)	31
Hose Connections	32
Site Tear-down (transport mode)	33
<u>SECTION IV</u> (<i>Operating the MAC JR 1200 Unit.</i>)	
Site set-up and pre-check	35
Mixing New Drilling Fluid	36
Transferring New Drill Fluid to Active Tank	37
Agitating the Active Tank	38
Cleaning the Dirty Fluid for Re-use	39
Shutdown, cleanup & storage	
Warm weather	40
Cold/ freezing weather	41
Prolonged Periods of Storage	42
<u>SECTION V</u> (<i>Trouble shooting</i>)	
Trouble Shooting the MAC JR 1200	44-45
<u>SECTION VI</u> (<i>Periodic Maintenance & Repair Information</i>)	
Maintenance Schedule	47
Bolt torque Specifications	48
Notes	49

TABLE OF CONTENTS

	PAGE
<u>SECTION VII</u> (<i>OEM Repair / Information</i>)	
Leveling Jack Breakdown	51-52
Gruvloc® Pipe Couplings	53-55
<u>SECTION VIII</u> (<i>Parts Manual</i>)	
MAC JR 1200E PARTS MANUAL	57-64



Limited Warranty

United States and Canada

Surface to Surface Inc. or its subsidiary which last sold the product, warrants new products sold by it for use in the United States and Canada to be, at the time of manufacture, free from defects in workmanship and materials. This warranty covers for a period of **Twelve (12) Months** of operation from the date of delivery for initial use, whichever comes first.

Exclusions and Additional Limitations

1. This warranty relates to the condition of the product at the time of manufacture and does not cover parts or service as a result of:
 - (a) Normal wear and tear or required maintenance including, without limitation, adjustments or replacement of components subject to wear and tear, such as belts, hoses, seals and/or packing, fuses, bulbs, switches and ignition parts.
 - (b) Abuse including, without limitation, neglect, improper operation, misapplication, overloading, accident or alterations not approved by Surface to Surface Inc.
 - (c) Lack of maintenance, including, without limitation, failure to inspect and maintain, improper repair, use of "unapproved parts", cracked engine heads and blocks unless caused by the failure of an internally lubricated part or repair of engine valves, rings or guides.
2. The Company's warranty does not apply to purchased components manufactured by others where separate warranty is made by the manufacture of such components and will be applied as interpreted by the supplier.
3. All claims under his warranty shall be submitted in writing by the distributor to the Company, which will be the sole judge in determining the merits of the claim.
4. The company shall have the right to have all products or parts claimed to be defective returned to it and the cost of shipping such items shall be borne by the distributor.

.....

Warranty Registration Card

In order to help us provide complete service for our product, please complete this card and return it.
If not returned, all requests for warranty will be denied.

Print Name:

Address:

City:State/Province.....Zip/PC.....

Model No. Serial No.

Date of Purchase Dealer

**Return to: Surface to Surface Inc.
5150 Forest Rd. RR#3
Watford, Ontario, Canada
N0M 2S0**



MAC JR 1200E

SAFETY STATEMENTS

Your personal safety and the safe operation of this unit are the concern of Surface to Surface Inc., and by reading and understanding this manual and understanding the safety statements, you will decrease the risk of personal and equipment damage.

Safety statements are listed here and throughout this manual to draw your attention to potential hazards that may be encountered while operating this piece of equipment. While reading this manual, you will notice that certain safety statements will relate directly to the operation, or maintenance of that particular part of the unit and should be followed carefully. Decals on the unit also follow the same format as the warnings in this manual, and therefore should be kept in good repair to alert the operator and others of the potential hazard.

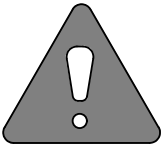

This safety alert symbol appears with most safety statements. It means attention, become alert, your safety is involved! Please read and abide by the message that follows the safety alert symbol.

 **DANGER**

Danger (the word "DANGER" is in white letters with a red rectangle behind it) indicates an imminently hazardous situation, which, if not avoided, will result in death or serious injury. Danger is limited to the most extreme situations.

 **CAUTION**

Caution (the word "CAUTION" is in black letters with a yellow rectangle behind it) indicates an potentially hazardous situation which, if not avoided, may result in minor or moderate injury.

 **WARNING**

Warning (the word "WARNING" is in black letters with an orange rectangle behind it) indicates an potentially hazardous situation which, if not avoided, could result in death or serious injury.

CAUTION

Caution "without the safety alert symbol" indicates an potentially hazardous situation that can cause damage to the, machine, personal property and / or the environment or cause the machine to operate improperly.

SAFETY STATEMENTS

The following caution statements have been drawn from the instructions in this manual. They have been assembled here for ready reference.

 **DANGER**

NEVER TRANSPORT
the unit without the wheel locks engaged in the transport position, the tongue extended and pinned and the leveling jacks fully retracted.

 **WARNING**

NEVER USE BODY PARTS, OR FOREIGN OBJECTS
in an attempt to unplug or clean the tank inlets or tank jet nozzels.
Serious personal injury or damage will result.

 **DANGER**

NEVER ATTEMPT TO PUT THE UNIT INTO OPERATION
without lowering the unit to the ground and leveling with the jacks.
Serious personal injury will result.

 **WARNING**

DO NOT REMOVE OR MODIFY SAFETY COVERS OR GUARDS.
Serious personal injury will result.

 **DANGER**

IN AN EMERGENCY
STOP the mixer / pumping unit to halt the pump, and fluid flow

 **WARNING**

NEVER ATTEMPT TO REMOVE OR CLEAN THE HYDRO-CYCLONES
while the unit is in operation.
Serious personal injury will result.

 **DANGER**

NEVER ATTEMPT REPAIRS OR DISASSEMBLY
without shutting off the mixing unit and disconnecting any power sources.
Serious personal injury will result.

 **CAUTION**

DO NOT POSITION ANY PART OF YOUR BODY
over the under-flow or over-flow box while operating.

SAFETY STATEMENTS *continued*

The following caution statements have been drawn from the instructions in this manual. They have been assembled here for ready reference.

⚠ CAUTION

WHEN THE UNIT IS IN OPERATION,
the fluid in the piping and hoses may reach pressures up to 50 p.s.i.

CAUTION

AVOID ALLOWING FOREIGN MATERIAL into the Tanks.

CAUTION

BEFORE STARTING OR RESTARTING the mixer, make sure the suction valve on the proper tank is open, and the fluid level in the tank is above the suction port.

CAUTION

CARE MUST BE TAKEN WHEN INSTALLING THE COUPLER GASKETS. If the gaskets are not properly lubricated and installed, a leak may develop.

CAUTION

TRAPPED FLUID MAY BE PRESENT and will spill out when piping or hoses are removed.

CAUTION

CARE MUST BE TAKEN WHEN CONNECTING THE HOSE COUPLINGS. The faces must be clean before mating together. Rotate body to engage lock.

CAUTION

NEVER LEAVE LIQUID IN THE PIPING, HOSES OR TANK during freezing weather conditions, as damage will result. Follow instruction for winterizing.

CAUTION

DO NOT CONNECT CHAINS OR STRAPS to piping or other parts of the unit. D-Hooks are provided on the base structure for such use.

SAFETY STATEMENTS *continued*

The following caution statements have been drawn from the instructions in this manual. They have been assembled here for ready reference.

CAUTION
<p>The manufacturer should be consulted when considering alternative uses for this piece of equipment. This unit was designed for the mixing, cleaning and storing of drilling fluid. Other uses may create unforeseen safety issues and personal injury risk.</p>

	WARNING
	<p>REFER TO THE SAFETY STATEMENTS IN THE OEM MANUALS SUPPLIED AND THIS MANUAL REGARDING THESE OPERATIONS.</p>

MAC JR 1200E

Safety Markings

Hazard and warning markings have been placed at appropriate points on the unit. International symbols have been used, in order to ensure universal understanding of the nature of the hazard. Please comply with all warnings and markings to ensure safe use of the equipment.

These include but are not limited to:

- | | |
|-----------------------------|--|
| a) Valve Operations | b) Valve Identification |
| c) Outlet Descriptions | d) Personal Protection recommendations |
| e) Personal dangers | f) Equipment dangers |
| g) Maintenance instructions | h) Fluid flow direction |

SOME EXAMPLES FOUND ON THE EQUIPMENT



Personal Protection, Read and understand Operator's manual and Maintenance manual

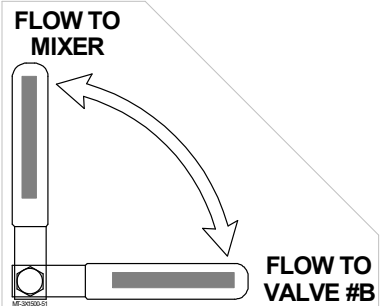

Valve Operations



Valve Identification



Outlet Descriptions



⚠ WARNING

BEFORE TRANSPORTING

- ALL Tanks **MUST** be Empty.
- **SECURE** Wheel Locks

BEFORE OPERATING

- Unit **MUST** be on the ground and **LEVELED** with jacks, **BEFORE** Filling with fluid

MT-3X1600-54

Equipment Dangers



Fluid Flow Direction



Maintenance Instructions

MAC JR 1200

Main Working Components

(Unit shown with M2-E922 mixer)

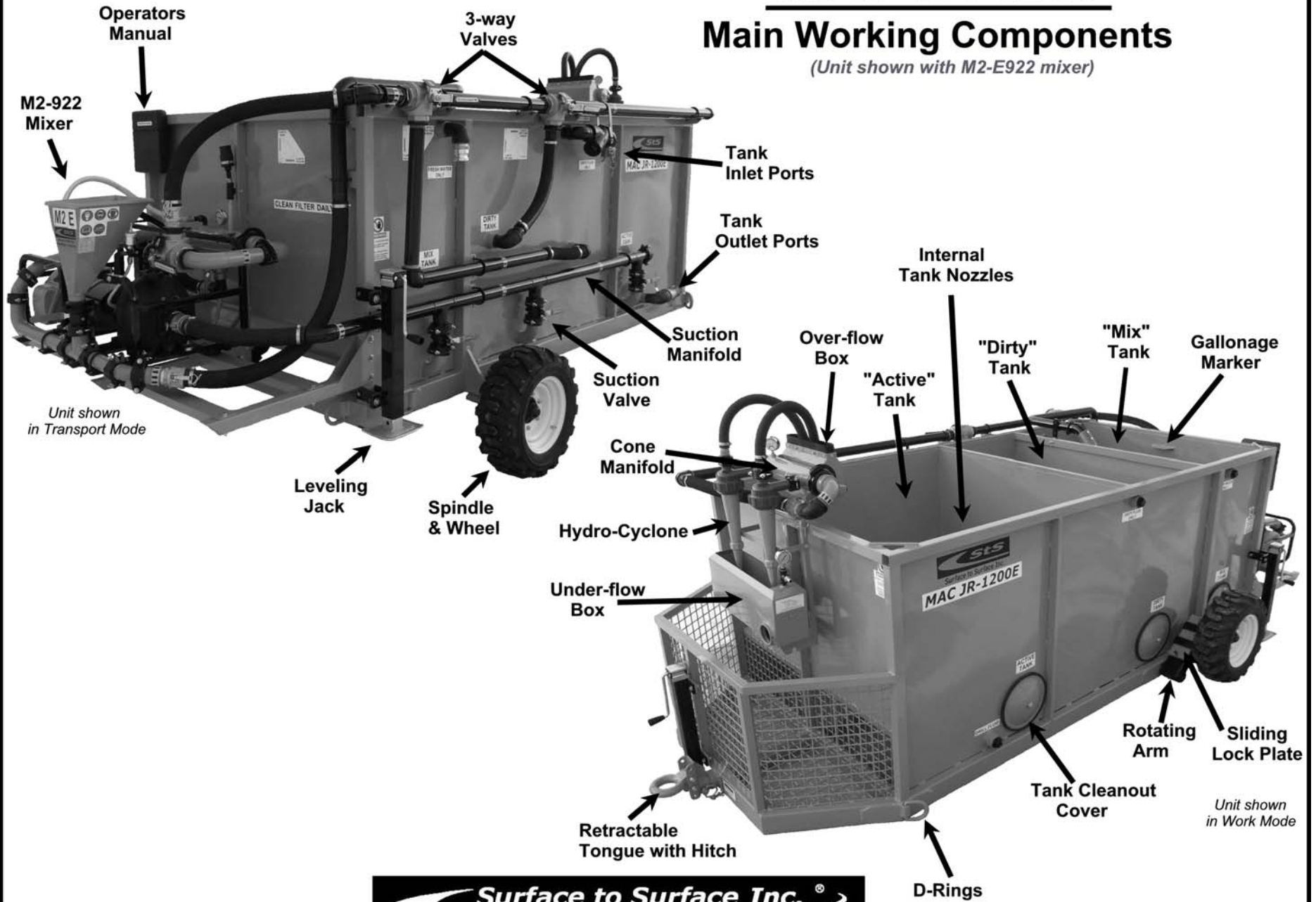



MAC JR 1200E
Operators Manual

Congratulations on your acquisition of the MAC JR 1200 drill fluid mixing and recovery system. You have acquired the most efficient fluid system manufactured, for mixing bentonite drilling slurry (mud) and fluid recovery system on the market. As a manufacturer of drilling support equipment, we are well aware of the extreme conditions that drilling equipment is exposed to on a daily basis. Surface To Surface Inc. strives to overcome these conditions, with better design and manufacturing practices. Please feel free to call our toll free number (1-800-567-0978) if you have any questions or concerns about your system.

Thank you, for choosing the MAC JR 1200 system.

The MAC Junior 1200 was designed to mix drilling fluid, clean and recycle used drill fluid, and maintain proper drilling fluid in an active tank for the drilling rig. The MAC Junior 1200 is built as one unit that includes 3 tanks, each with injector nozzles, a manifold assembly of hydro-cyclones, a STS M2 mixer and all the valves and piping to needed to create a smooth and effortless system.

The unit is designed to be operated on ground level. When the unit is to be transported it is jacked up, letting the wheels rotate down and into position, were they are secured and locked in place, creating 12” of ground clearance for transporting over uneven terrain. Once on location, lower jacks and take the weight off of the wheels, release the locks and lower to ground level.

The mixer located at the rear of the unit is designed around the time proven M series mixers of STS.

The MAC Junior 1200E consists of an electric powered centrifugal pump, filter/shear unit, venturi mixing tee assembly, dry hopper and pressure wash wand, making effective use of the 4 point mixing system.

The hydro-cyclones are 2 1/2” with a capacity of 16 us. gpm each and a D-cut of 5 micron. As the fluid is processed with the hydro-cyclones, the over-flow (clean) fluid is routed into the active tank for reuse.

For ease of interpretation, looking at the tongue (hitch) straight on will be considered looking at the front of the unit. Hence the M2 mixer will be the rear and the sides will be right or left.

RECORD OF OWNERSHIP:

- Unit Serial No. _____
- Pump Serial No: _____
- Date Purchased/Leased: _____
- Dealer Purchased/Leased From: _____
- Special Custom Features: _____

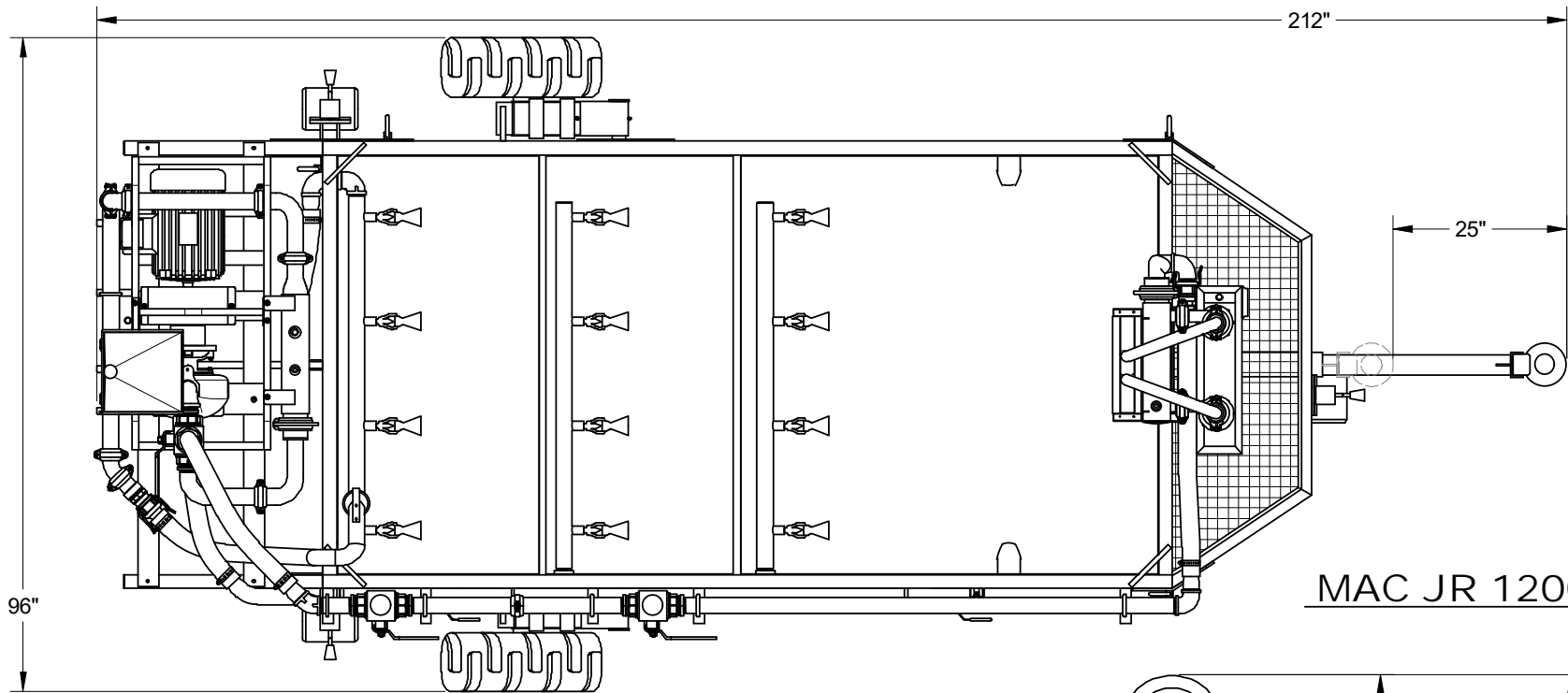

MAC JR 1200E

(Transport mode) ** wheels down, tongue extended
 (Work mode) ** wheels up, tongue retracted

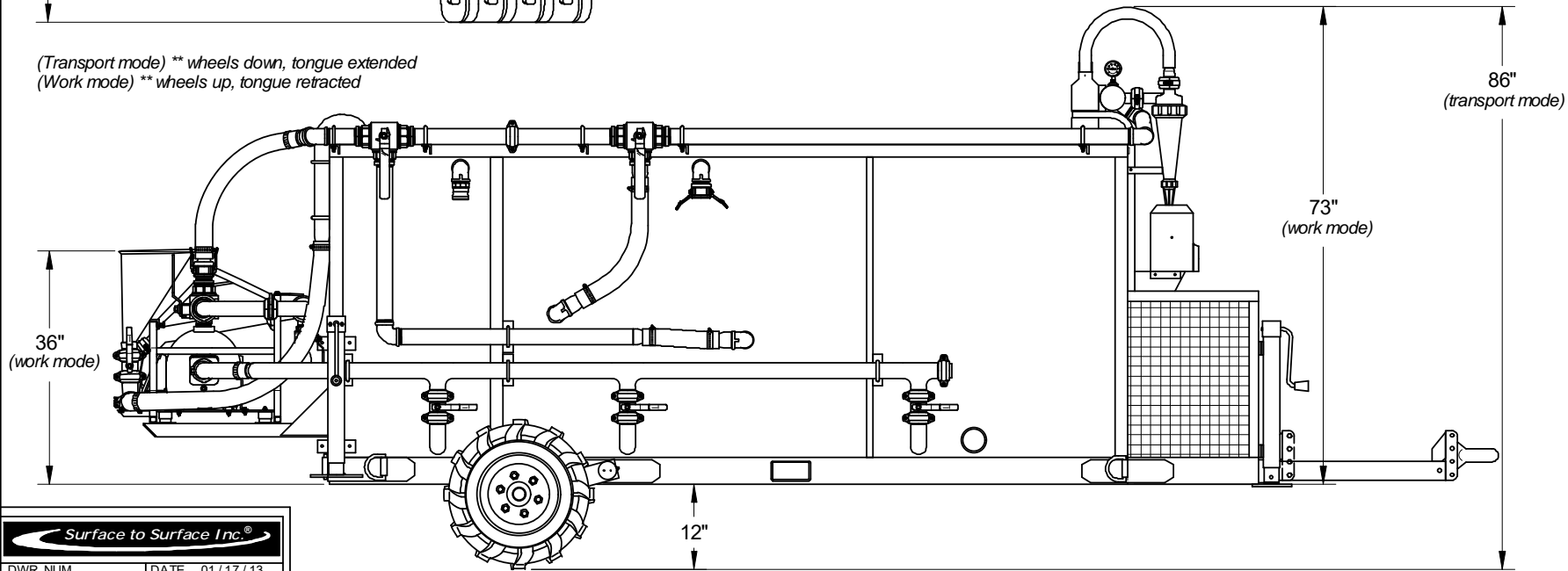

Surface to Surface Inc.®

DWR. NUM.	DATE: 01/17/13
MAC JR 1200E	REV. 03/15/19



Mix-Clean-Recover Unit Model MAC Junior 1200E

Surface to Surface Inc.

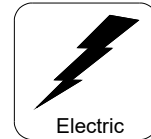

Unit shown with a M2-E922 mixer



Features and Benefits: **MAC Junior 1200E**

The MAC Junior 1200E was designed to mix drilling fluid, clean and recycle used drill fluid, and maintain proper drilling fluid in an active tank for the drilling rig. The MAC Junior 1200 is built as one unit that includes 3 tanks, a manifold assembly of hydro-cyclones, a STS M2 mixer and all the valves and piping to needed to create a smooth and effortless system needed to satisfy the customer's needs.

The unit is designed to be operated on ground level with a tank height of 50 inches, so the operator can over-see the process, and visually inspect inside of the tanks without ever having to climb up or down causing a safety issue. When the unit is to be transported from location to location, the unit is jacked up with the 3 onboard jacks letting the wheels rotate down and into position, where they are secured and locked in place. This creates 12" of ground clearance for transporting over uneven terrain. Once on location, lower jacks and take the weight off of the wheels, release the locks and lower to ground level.

The mixer located at the rear of the unit is designed around the time proven M series mixers of STS. The MAC Junior 1200E is powered by a 10HP Teco/Westinghouse electric motor, driving a 2" centrifugal pump, making effective use of the renowned 4 point mixing system. With the proper valve selection, this one motor and pump will do all of the functions required to operate the unit effectively and efficiently, thus reducing mechanical and maintenance issues.

With a hopper height of only 36" from the ground, operator fatigue from loading bags into the hopper is reduced. The mixer blends and shears the new drilling fluid in the rear 300 us. gallon tank. A set of 5-1 injector nozzles in combination with a rolled bottom tank design keeps the fluid agitated and consistent. When the operator has the proper drill fluid made, simply rotate a valve on the mixing unit and route the fluid to the front active tank. The active tank will hold 600 us. gallons of drilling fluid for the drilling rig to draw from. This tank is also designed with a rolled bottom and a set of 5-1 injector nozzles to keep the fluid agitated and consistent.

The tank in the center of the unit has a capacity of 300us. gallons for storing "dirty, spent" drill fluid from the drill hole. This tank is filled by a customer supplied pit pump usually of the 2" size. When the "dirty" tank is full, the pump on the mixer is used to draw "dirty" fluid from the center tank and route it to the front mounted hydro-cyclones. While routing fluid to the hydro-cyclones the pump also uses the "dirty" tank's rolled bottom and set of 5-1 injector nozzles to keep the dirty fluid agitated and consistent. The hydro-cyclones are 2 1/2" with a capacity of 16 us.gpm each and a D-cut of 5 micron. As the fluid is processed with the hydro-cyclones, the over-flow (clean) fluid is routed into the active tank for reuse. The underflow (solids) are routed out and away for customer disposal or optional secondary treatment.

Each tank is open top and has side clean out access. The tanks are equipped with the required inlet-outlet connections on both sides of the tank to allow for better external hose routing and to eliminate hoses over the top and tied. The frame has many securing and tie-down points located in key spots.

This unit was designed for operator safety, site safety, ease of use, portability, small footprint and maximizing drilling fluid handling efficiency.



Mix-Clean-Recover Unit Model MAC Junior 1200E

Surface to Surface Inc.

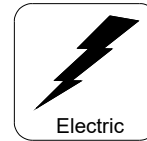

Specifications

Dimensions (Working)
 Dimensions (Transporting)
 Weight without Mixer
 Weight including Mixer
 Hopper Height & Size
 Hydro-cyclones
 Piping
 Flow Valves
 Quick coupling connectors
 Tanks
 Tank nozzles (4 per tank)
 Threaded inlet & outlet ports
 Leveling Jacks
 Tires
 Retractable tongue
 Large storage area
 Mixing System

MAC Junior 1200E Unit

96" W x 187" L x 72" H
 96" W x 212" L x 86" H
 2500 lbs.
 3000 lbs. (M2-E922)
 36" High Holds 1/2 of a bag
 2 @ 2 1/2" 16 gpm
 2" sched. 40 Pipe
 Brass and Steel construction
 2" cam loc
 2 @ 300us gal, 1 @ 600us gal
 Educator Nozzles (5-1 fluid output)
 2" NPT
 3 HD screw jacks
 23 / 8.5 x 12 x 6 ply
 Retracts 24" under unit
 Caged with open top
 2" StS Mixing System

Benefits

Small foot print operate from ground level
 12" of ground clearance
 Light weight for easy transportation.

 Low hopper height reduces back strain.
 D-cut of 5 micron
 Built tough for the construction trade.
 Withstand the abuse of daily operations
 Ease of connections and draining
 Rolled bottom with clean out
 Fast and effective rolling and mixing action.
 Safe Proper connections, no hoses over the top
 Allows for 3-point leveling of unit
 Stand up to rugged terrain
 Smaller working footprint. Avoids tripping hazard.
 Keep hoses & accessories all in one place
 Fast & efficient with high shearing ability.

Optional Fluid Recovery from the Hydro-cyclone discharge is available.

Specifications

Dimensions
 Weight
 Hopper Height & Size
 Mixing System
 Flow Valves
 Skid Frame
 Motor
 Pump
 Pump / Motor Connection
 Pipe Couplers
 Pressure Wand
 Mechanical Seal
 Replaceable Wear Plate
 3-way Valves

M2-E922 Mixer

33" W x 52" L x 26 1/2" H
 500 lbs. (227 Kg)
 26 1/2" High Holds 1/2 of a bag
 2" Renowned StS Mixing System
 Brass and Steel construction
 1" steel tube with lifting bale
 10 HP Teco 230V/460V 60Hz
 2" Cast iron centrifugal trash pump
 Bearing Block to Lovejoy® Coupler
 Bolt & Snap-groove type
 Hopper maintenance wand
 Self Pressurizing Grease Seal
 Hardened plate ahead of Impeller
 2 1/2" NPT Port, 2 position

Benefits

Small space saving footprint.
 Light weight for easy transportation.
 Low hopper height reduces back strain.
 Fast & efficient with high shearing ability.
 Withstand the abuse of daily operations
 Built tough for the construction trade.
 Industrial rated for longer service life
 Gorman-Rupp 80 series
 Large bearings & oversized coupler (service life)
 Fast cold weather draining of system.
 Removal of build-up caused by additive.
 Greaseable seal for more rugged working conditions
 Less wear on internal pump parts and is replaceable.
 Designed for heavy duty slurry use. Large handles.

With a 40 second viscosity, the M2 model produces 90 gpm @ 36psi through the mix nozzle and 52 gpm @ 36psi to the tank nozzles (5-1 mixing equals 260 gpm of mixing / rolling action in tank) and a discharge rate of 80 gpm @ 36psi

Also available in Hydraulic (MAC Junior 1200H) or Diesel (MAC Junior 1200D) models.

*** All Specifications Subject to Change Without Notice ***

Check our website for the latest products and specifications
www.stsmixers.com

Surface to Surface Inc.

5150 Forest Road, R.R.#3, Watford, Ontario, N0M 2S0
Tel: 1-800-567-0978

03/15/19

MAC JR 1200E

Identifying Your Machine & Components

Location of Tags and PIN Plates

Unit
Serial Number

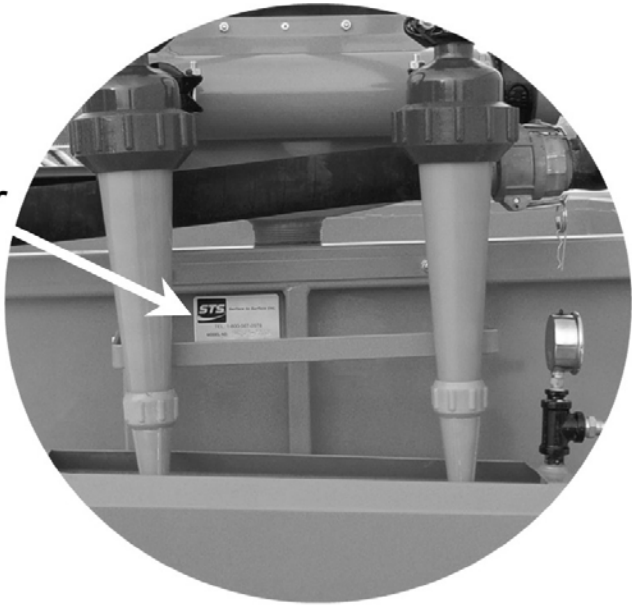

SECTION #II

Description, Care and Maintenance

MAC JR 1200E

Description, Care and Maintenance

Base Skid with Tanks

The base skid is built to support the 3 tanks and allow the unit to be transported from work site to work site with a unique set of wheels that can be raised or lowered (Fig.1a) and a retractable tongue (Fig.1b) for connecting to a transporting device. The base skid has various connecting points (D-rings) to attach a chain, cable or strap, if the need arises. Maintenance of the base itself is minimal. It should be kept clean and a visual inspection of the welds and tubing structure should be done on a daily bases. Connecting points (D-rings) should also be checked for wear or damage before using. The retractable tongue should also be kept clean to enable it to “retract” into the base skid. The hitch on the tongue will need to be checked for any wear or damage that would render it un-safe for towing.

Mounted on each side of the base skid, is a rotating arm (Fig.1a) with a spindle hub and a rubber tire. On top of the rotating arm is a sliding lock plate that stops the arm assembly from rotating while in the transporting position. There is a grease fitting located on the end of each arm that should be greased on a monthly basis. The sliding lock plate should be kept clean and free of debris to allow easy movement of the plate back and forth.

The lug bolts that attach the wheel to the spindle should be checked daily and tightened if needed. The air pressure in the tires should be checked regularly and maintained at the manufactures recommended pressure, which is stated on the side wall of the tire. The bearings inside of the spindle should be serviced as per the service schedule.

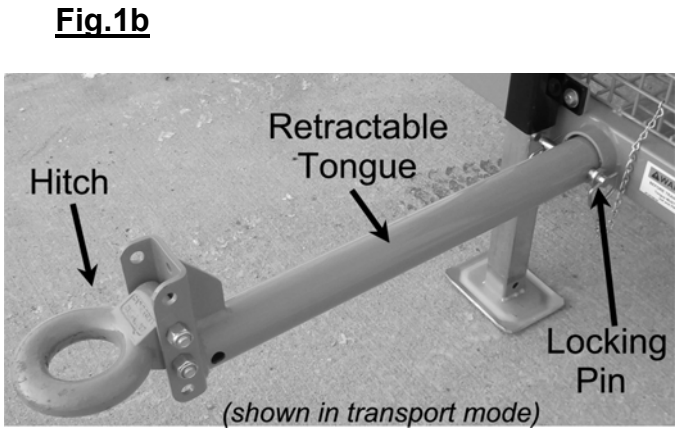
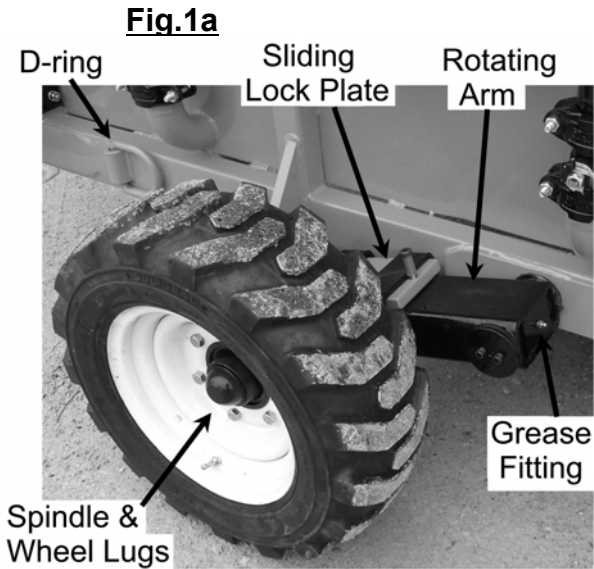

⚠ DANGER

NEVER TRANSPORT the unit without the wheel locks engaged in the transport position, the tongue extended and pinned and the leveling jacks fully retracted.

⚠ DANGER

NEVER ATTEMPT TO PUT THE UNIT INTO OPERATION without lowering the unit to the ground and leveling with the jacks. Serious personal injury will result.

CAUTION

DO NOT CONNECT CHAINS OR STRAPS to piping or other parts of the unit. D-Hooks are provided on the base structure for such use.

MAC JR 1200E

Description, Care and Maintenance

Base Skid with Tanks

There are 3 tanks atop of the base skid. The front tank is 600us. gal, and is referred to as the “active” tank. The middle tank is 300us. gal and is referred to as the “dirty” tank. The back tank is also 300us. gal and is referred to as the “mixing” tank.

Each tank is equipped with a removable clean out cover (Fig.2a), which is easily taken off by removing the center bolt. There is a rubber gasket ring around the cover itself and this gasket should be cleaned before reinstalling the cover back on the tank. Do not over-tighten.

The tanks should be checked regularly for any debris or sediment that may have accumulated on the bottom and cleaned out before the next use.

Each tank has gallonage marker(s) (Fig.2b), mounted on the inside wall. The markers indicate US. gallons. Tanks should never be filled above the top marker of the tank.

Fig.2a



Fig.2b

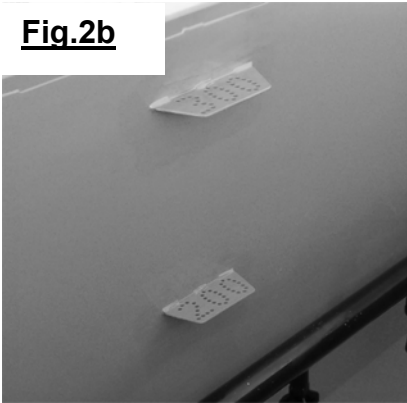

CAUTION
NEVER LEAVE LIQUID IN THE PIPING, HOSES OR TANK during freezing weather conditions, as damage will result. Follow instruction for winterizing.

CAUTION
BEFORE STARTING OR RESTARTING the mixer, make sure the suction valve on the proper tank is open, and the fluid level in the tank is above the suction port.

CAUTION
AVOID ALLOWING FOREIGN MATERIAL into the Tanks.

MAC JR 1200E

Description, Care and Maintenance

Base Skid with Tanks

The middle and back tanks have labeled inlet ports (Fig.3a, 3b), on both sides of the unit, to receive the appropriate (labeled) fluid and should be used to make a safe and solid connection for the filling hoses. It is recommended that the inlet port of the middle “Dirty” tank be protected with a screening device such as the screening basket (supplied) (Fig.3c) to stop large debris from entering the tank, that may damage or plug the hydro-cyclones. This filtering device should be cleaned on a daily basis.

The front “Active” tank has labeled discharge ports (Fig.3d) located on both sides, were the connection for the drilling rig is to be made. A valve is mounted to this discharge port to stop the flow of fluid from the tank.

With solid port connections available, there should be no need to have hoses draped over the top of the tanks, creating an operator hazard.

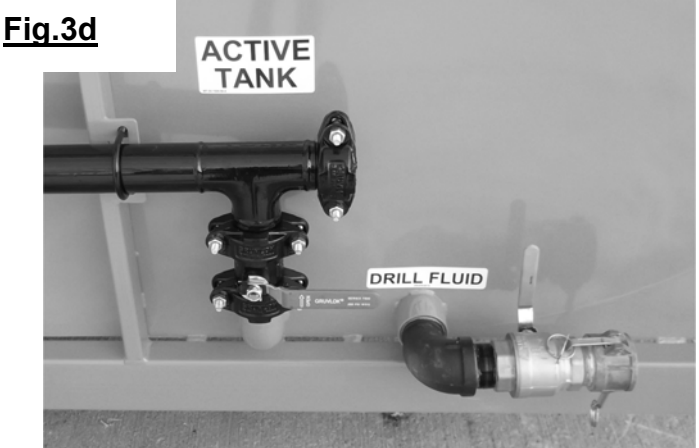
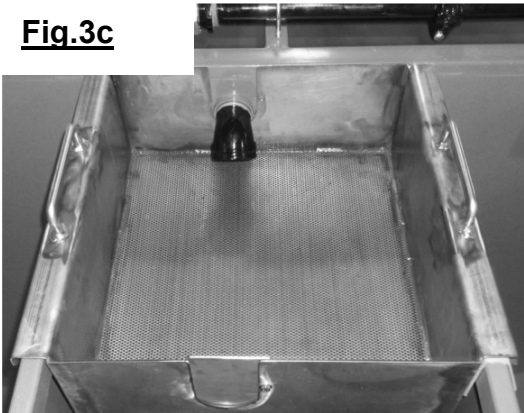
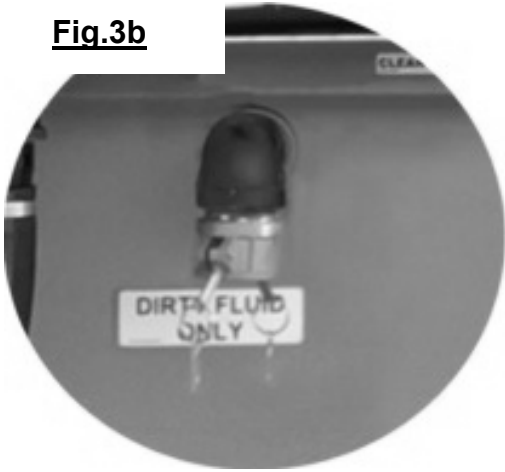

⚠ WARNING

NEVER USE BODY PARTS, OR FOREIGN OBJECTS
 in an attempt to unplug or clean the tank inlets or tank jet nozzels.
 Serious personal injury or damage will result.

CAUTION

TRAPPED FLUID MAY BE PRESENT and will spill out when piping or hoses are removed.

CAUTION

CARE MUST BE TAKEN WHEN CONNECTING THE HOSE COUPLINGS. The faces must be clean before mating together. Rotate body to engage lock.

MAC JR 1200E

Description, Care and Maintenance

Internal Tank Nozzles

Inside each tank is a set of internal tank nozzles (Fig.4a) mounted on a pipe manifold (Fig.4b). The manifold spans the tank width and the nozzles are spaced on the manifold to achieve proper coverage of the tank bottom. The nozzles stir the fluid to achieve a rolling action which keeps the fluid and solids in suspension and a consistent mixture of fluid. The nozzles use a venturi effect to create a 5-1 fluid stream See (Fig.4c) for a detailed explanation.

The internal tank nozzles requires little or no maintenance and will only require attention if they become clogged. Flushing the entire system weekly with clear water should eliminate any problems with this piece of the system. The fluid passing through the internal tank jets is at a very high pressure and extreme caution should be used when viewing the inside of the tank.

Fig.4a



Fig.4b

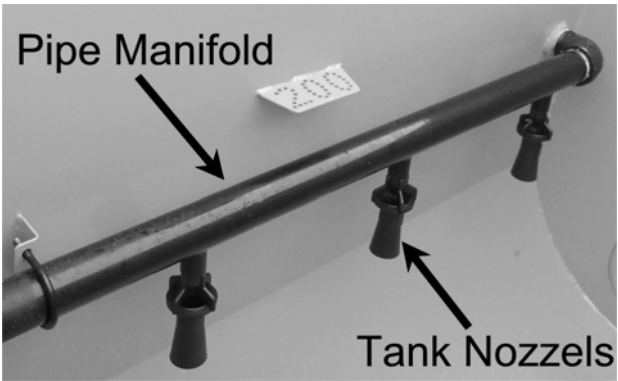
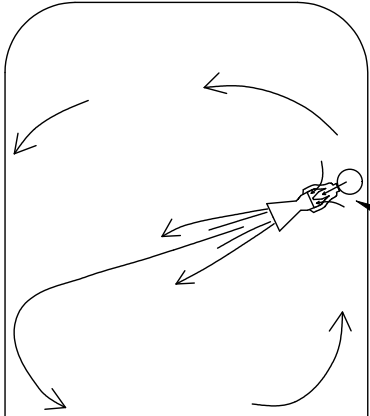
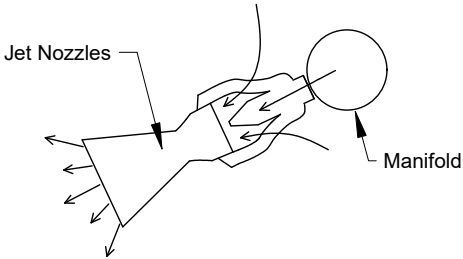



Fig.4c

For every gallon of fluid passing through the jet nozzle from the manifold pipe, the jet nozzle will draw in another 4-5 gallon more from around the outside of the nozzle, creating a larger volume of fluid movement in the tank.

Connect the manifold to the outlet on the filter/shear of the STS Mixing Unit. Each unit is shipped with 2-4 jet nozzles that have been properly sized for the unit.



ALL Jet Nozzles are mounted on one side of the tank to create a rolling effect in the tank.

 DANGER
IN AN EMERGENCY STOP the mixer / pumping unit to halt the pump, and fluid flow

 WARNING
NEVER USE BODY PARTS, OR FOREIGN OBJECTS in an attempt to unplug or clean the tank inlets or tank jet nozzels. Serious personal injury or damage will result.

CAUTION
AVOID ALLOWING FOREIGN MATERIAL into the Tanks.

MAC JR 1200E

Description, Care and Maintenance

External Piping

Mounted on the exterior of the tanks is a series of piping and valves (Fig.5) that allow the operator to move fluid from mixer to tanks and or tank to tank. The suction manifold is located at the bottom of the tanks and each tank has a valve installed to control the fluid flow. This suction manifold and valves are of the grooved design and a grooved coupler (clamp) is used to connect the assembly together. These clamps are explained in detail in section VII of the manual. Flushing the system with fresh water regularly will keep the pipe and valves clean and remove any build-up that may occur.

The remaining pipes are discharge piping and are made up of threaded connections, fittings, rubber hoses, and 3-way ball valves. The fluid flow direction is decaled on the pipes to aid in the operation of the unit.

When fluid is routed through the discharge pipes, it is under pressure and should be treated as such. The piping and fittings requires little maintenance. The rubber hose and clamps should be visually checked daily for cracks, holes, or damage, and the clamps should be kept tight. Flushing the system with fresh water regularly and cycling the valves open & close while flushing with water, will keep the pipes and valves clean and remove any build-up that may occur.

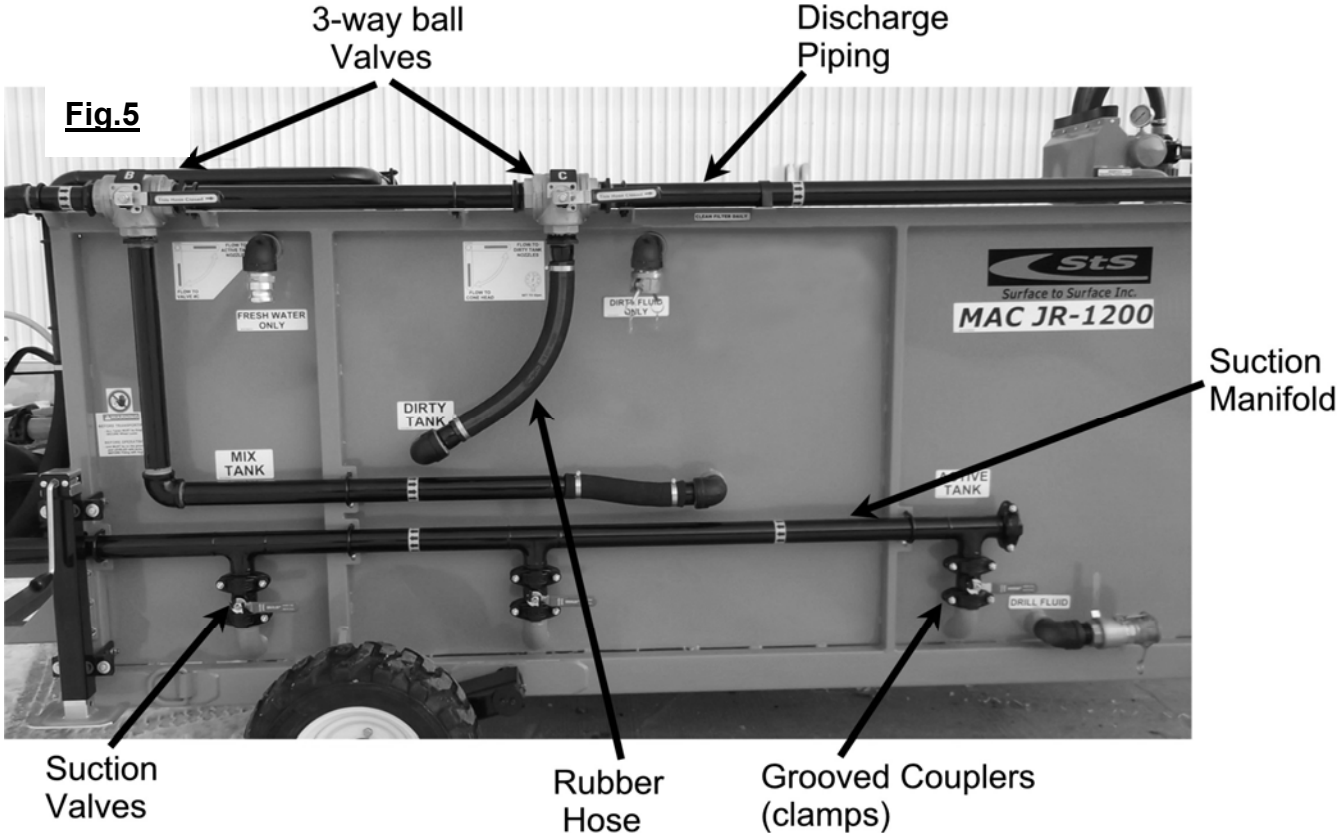

 DANGER
NEVER ATTEMPT REPAIRS OR DISASSEMBLY without shutting off the mixing unit and disconnecting any power sources. Serious personal injury will result.

 CAUTION
WHEN THE UNIT IS IN OPERATION, the fluid in the piping and hoses may reach pressures up to 50 p.s.i.

CAUTION
NEVER LEAVE LIQUID IN THE PIPING, HOSES OR TANK during freezing weather conditions, as damage will result. Follow instruction for winterizing.

MAC JR 1200E

Description, Care and Maintenance

Leveling Jacks

Mounted on the back corners and on the front of the MAC JR 1200 are crank type leveling jacks (Fig.6). These jacks are used to raise and lower the unit for transporting, and when setting up on site, to level the unit on uneven ground.

CAUTION: the jacks must be fully retracted when in the transport mode to avoid being bent. These jacks will require little maintenance other than to keep clean of mud and debris, and should be serviced as per the service schedule.

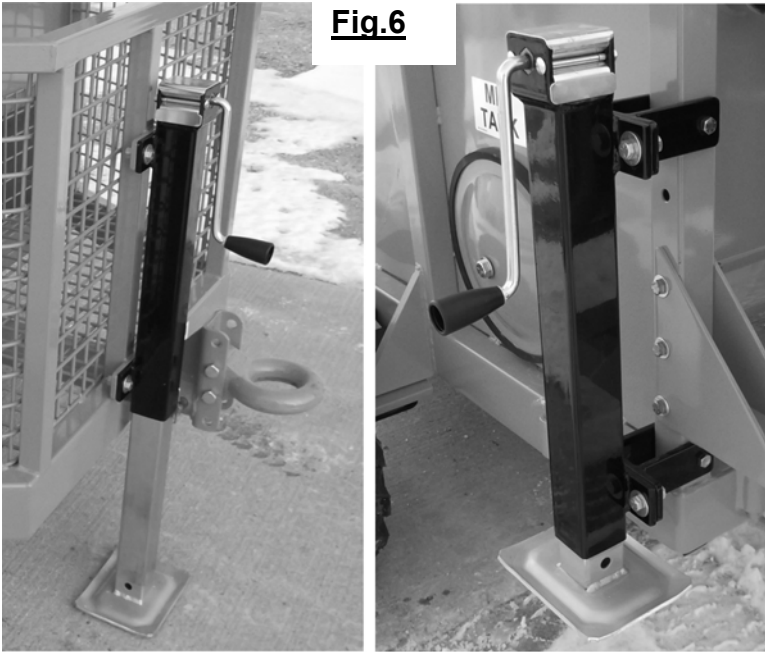

Front Jack
(Extended)

Rear Corner Jacks
(Retracted)

⚠ DANGER

NEVER ATTEMPT TO PUT THE UNIT INTO OPERATION
without lowering the unit to the ground and leveling with the jacks.
Serious personal injury will result.

⚠ DANGER

NEVER TRANSPORT
the unit without the wheel locks engaged in the transport position, the tongue extended and pinned and the leveling jacks fully retracted.

MAC JR 1200E

Description, Care and Maintenance

2 Cone Head Assembly

The 2 cone head assembly (Fig.7) is mounted on the front of the MAC JR 1200, over top of the active tank.

The head assembly consists of 4 key components that are explained in more detail in following pages. The cone manifold, equally distributes the incoming fluid to the hydro-cyclones. The Hydro-cyclones separate the drill fluid into two flow streams defined as over-flow and under-flow. The over-flow box is positioned at the back, over the active tank. The under-flow box is at the front, mounted beneath the hydro-cyclones. All of these components are mounted together on one removable bolt-on frame.

The MAC JR 1200 must be in the work mode (wheels up) and level for the head assembly to work properly. This will allow the fluid to flow in the proper directions (out the outlets) and stop pooling of the fluid in the boxes.

After transporting from site to site, and setup to work, the hydro-cyclones may rotate from vibration and should be checked and if needed, rotate back to the vertical position.

Although there is no moving parts to maintain, the head assembly should be kept clean and flushed with clean water on a daily basis.

OPTIONAL: This unit can be equipped with an optional water recovery injection system and therefore additional parts may be pre-mounted. These parts may include a nozzle, weir plate, pressure gauge and a small hose connection, all of which are located inside and outside of the under-flow box.

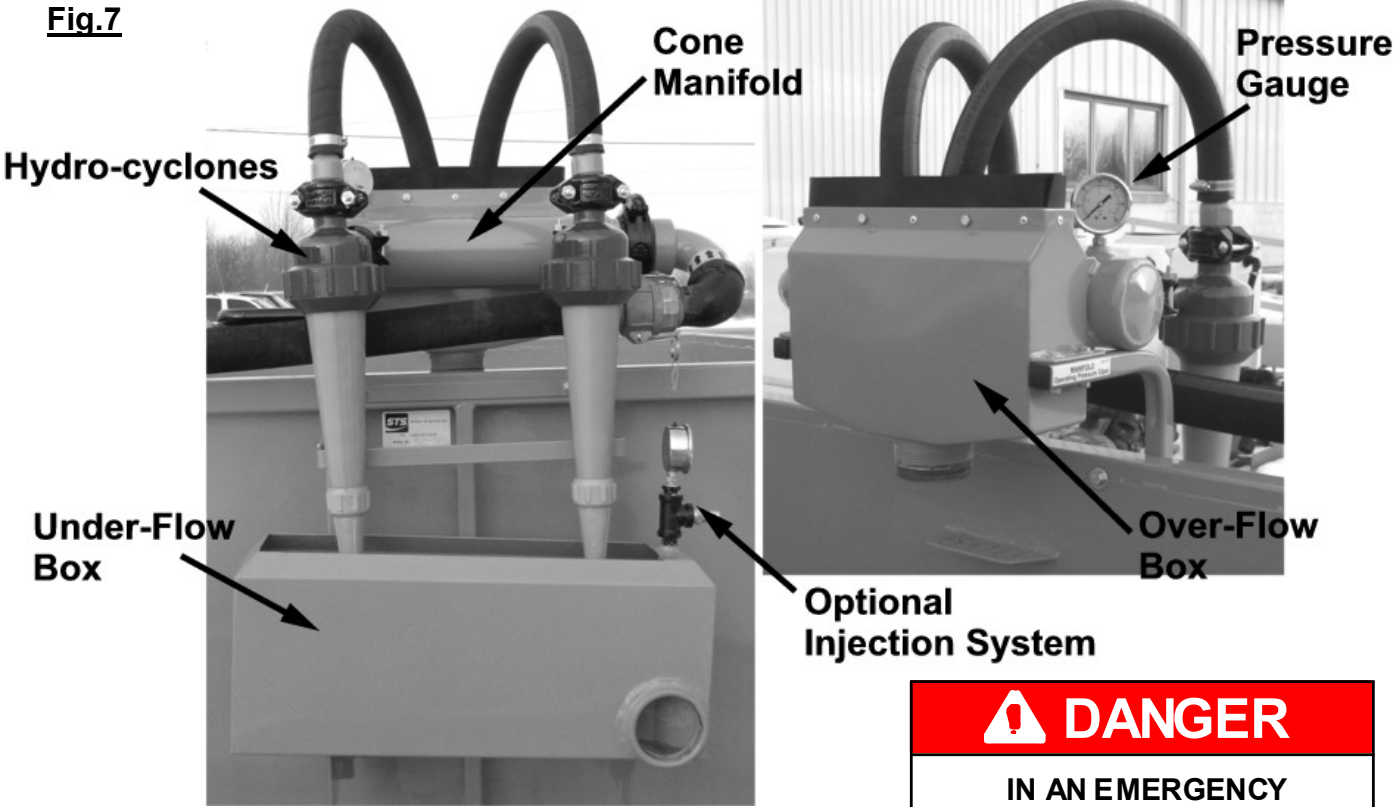

⚠ DANGER

IN AN EMERGENCY

STOP the mixer / pumping unit to halt the pump, and fluid flow

MAC JR-1200

Description, Care and Maintenance

Cone Manifold

The cone manifold (Fig.8) allows the oncoming fluid to be evenly distributed to the 2 hydro-cyclones. The cone manifold has a removable inlet pipe to allow for cleaning or winterizing.

The manifold has a pressure gauge mounted on top. This gauge measures the fluid pressure inside the manifold, to set and keep the hydro-cyclones at the proper operating pressure “see affixed label on unit”.

The inlet end of the manifold should be removed regularly and rinsed out to remove any solids build-up that has settled out and collected on the bottom of the manifold.

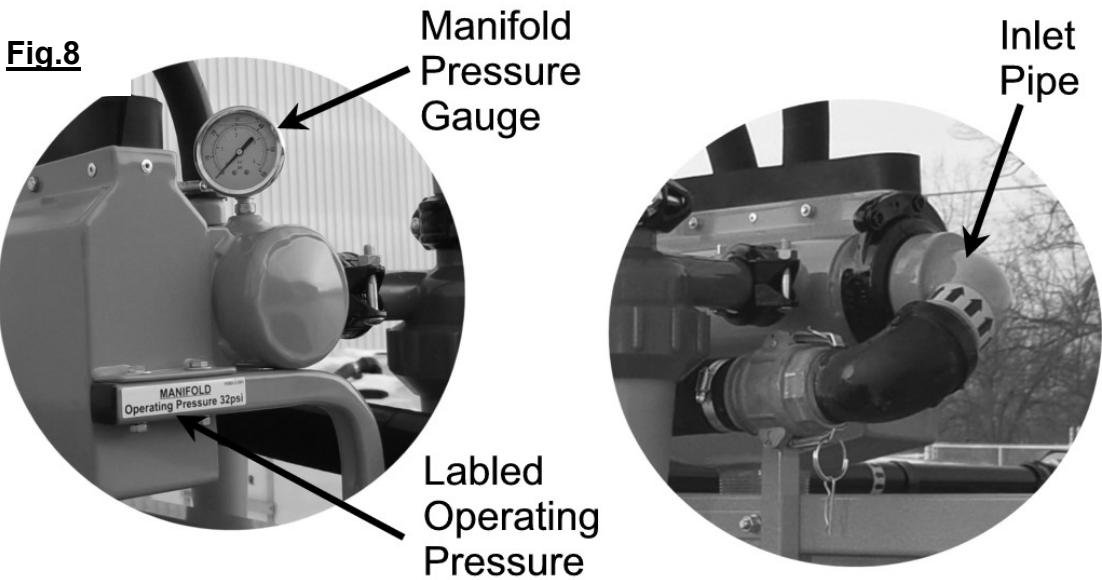

⚠ DANGER
IN AN EMERGENCY
STOP the mixer / pumping unit to halt the pump, and fluid flow

CAUTION
TRAPPED FLUID MAY BE PRESENT and will spill out when piping or hoses are removed.

⚠ DANGER
NEVER ATTEMPT REPAIRS OR DISASSEMBLY
without shutting off the mixing unit and disconnecting any power sources. Serious personal injury will result.

CAUTION
NEVER LEAVE LIQUID IN THE PIPING, HOSES OR TANK during freezing weather conditions, as damage will result. Follow instruction for winterizing.

⚠ CAUTION
WHEN THE UNIT IS IN OPERATION,
the fluid in the piping and hoses may reach pressures up to 50 p.s.i.

CAUTION
CARE MUST BE TAKEN WHEN INSTALLING THE COUPLER GASKETS. If the gaskets are not properly lubricated and installed, a leak may develop.

MAC JR 1200E

Description, Care and Maintenance

Hydro-cyclones

The Hydro-cyclones (cones) (Fig.9a) are the first step in cleaning process of the spent drilling fluid. The fluid enters the cones from the manifold and the flow and pressure create a spiraling effect (like a tornado) inside of the cone. This action forces the separation of heavier solids outward and downward to the bottom of the cone and exits through the apex of the cone. This is called the under-flow. As it exits the apex (Fig.9b) it will visually appear as a spray mist in the shape of an inverted hollow cone. This will indicate that the cone is working properly. If the discharge from the apex has a rope like stream coming out, then the cone is overloaded with solids and is not working properly. This usually indicated improper flow / pressure or the fluid being pumped to the manifold has a solids content that is extremely high and is too great for the cone to handle. If no fluid is discharging from the apex the cone is plugged and will require shutting off the flow to the manifold and dissembling the cone and to be cleaned.

As the fluid spirals inside the cone and separates, the lighter fluid rises upward and out the top of the hydro-cyclone. This fluid is called the over-flow and is the clean drill fluid that can be reused. It is directed by a curved hose (cane) mounted on top of the cone, and down into the over-flow box. The hydro-cyclone is made up of 3 parts (Fig.9a), head, body, and apex and has no moving parts inside. Due to the abrasive nature of the fluid entering and exiting the cone, wear is a factor with prolonged use and the cone will need to be replaced when this wear becomes excessive. Simply flushing the system with fresh water daily will keep the cones clean inside.

Fig.9a

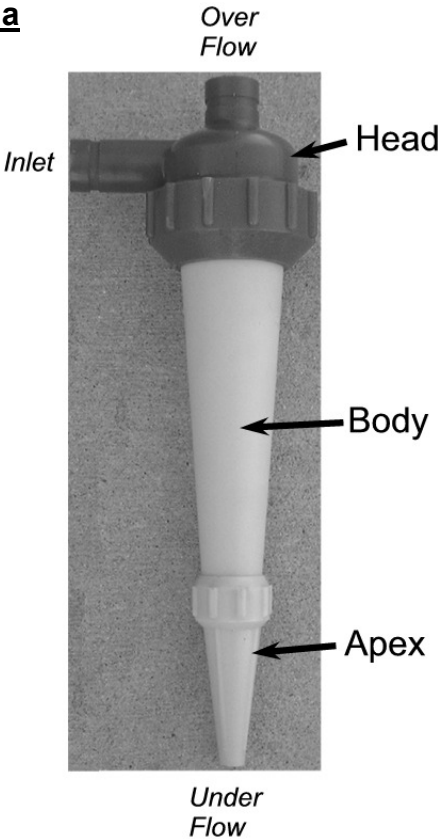
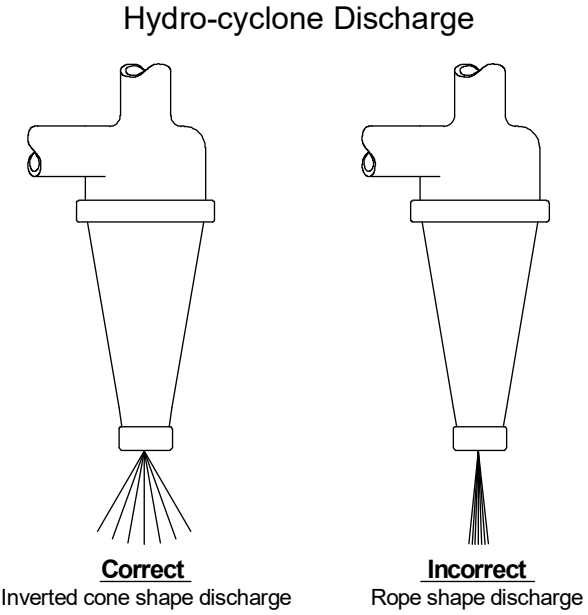

Fig.9b



WARNING
 NEVER ATTEMPT TO REMOVE OR CLEAN THE HYDRO-CYCLONES while the unit is in operation. Serious personal injury will result.

MAC JR 1200E

Description, Care and Maintenance

Over-Flow Box

The over-flow box (Fig.10a) is located on the back side. This box collects all the over flow from the 2 hydro-cyclones.

The hydro-cyclone over flow hoses (canes) are held in place by positioning the hoses in the center of the box between the 2 spacers (Fig.10b). The over-flow box has a single 3” NPT threaded outlet to direct the gravity flow down into the active tank to be reused in the drilling process.

The over-flow box should be rinsed daily with fresh water to clean any residue remaining in the box.

The hydro-cyclone hoses (canes) should be checked daily and every time the unit is moved, that they are pushed down between the spacers and have not pulled out.

Fig.10a

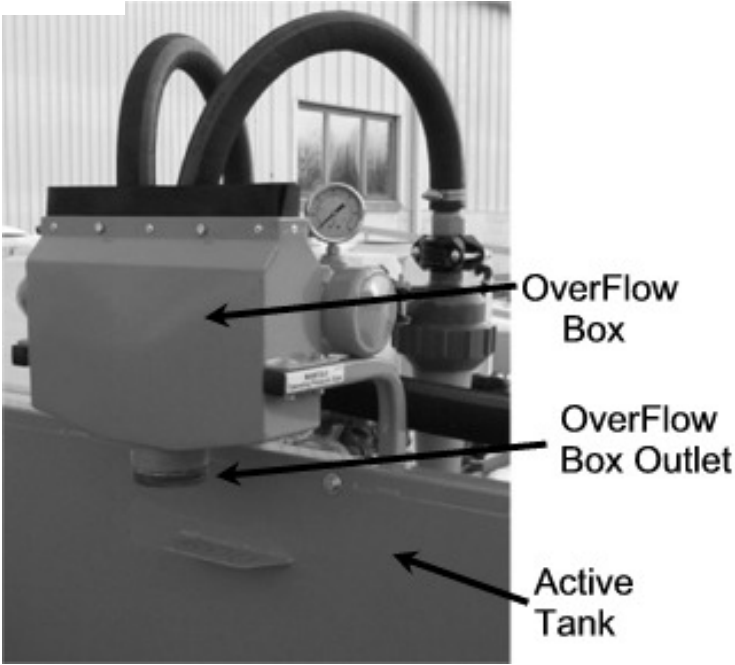
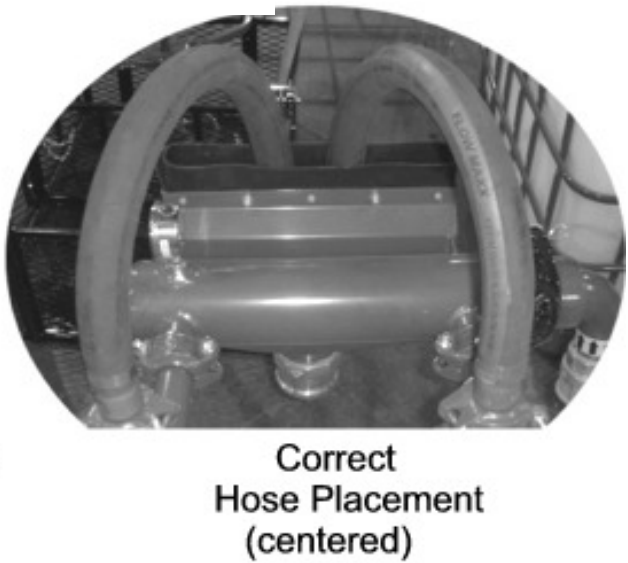

Fig.10b



⚠ DANGER
NEVER ATTEMPT REPAIRS OR DISASSEMBLY
without shutting off the mixing unit and disconnecting any power sources. Serious personal injury will result.

⚠ WARNING
DO NOT REMOVE OR MODIFY SAFETY COVERS OR GUARDS.
Serious personal injury will result.

⚠ CAUTION
DO NOT POSITION ANY PART OF YOUR BODY
over the under-flow or over-flow box while operating.

MAC JR 1200E

Description, Care and Maintenance

Under-Flow Box

The under-flow box (Fig.11a) is mounted on the front, underneath the hydro-cyclones. The under-flow from the hydro-cyclones sprays down onto the bottom of the box and then flows out of a 3” NPT threaded outlet. It is important that the box be kept clean of build-up or foreign objects (stones, leaves, etc.) that may enter from the open top, and disrupt the fluid path. By jetting clean water into the box, the buildup will be loosened and flow out through the outlet. Failure to remove any build up will stop fluid flow and render the box inoperable.

The 3” NPT threaded outlet allows for a hose connection to route the discharge away from the unit for disposal. If routing the fluid away from the under-flow box and into a container for disposal, this hose must be lower than the under-flow box to prevent backing up into the under-flow box (gravity discharge).

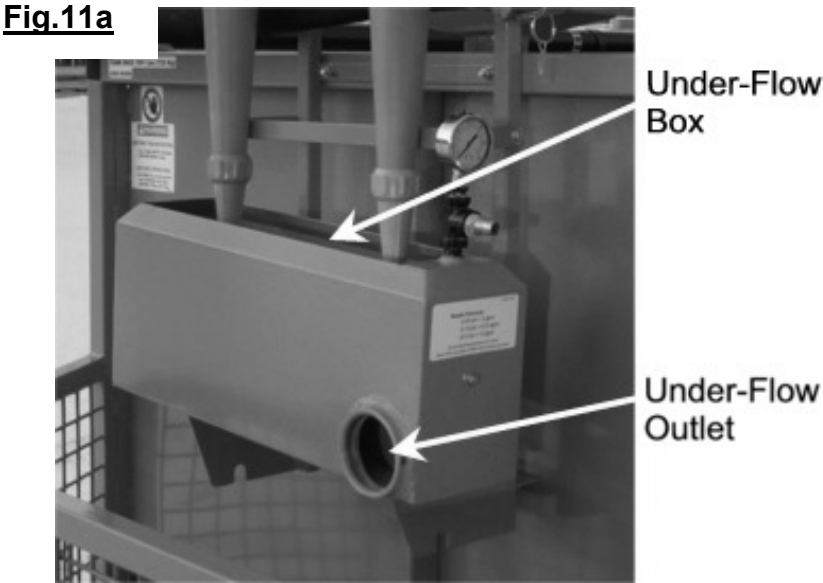

Shown with optional water recovery injection system

⚠ DANGER

NEVER ATTEMPT REPAIRS OR DISASSEMBLY
without shutting off the mixing unit and disconnecting any power sources. Serious personal injury will result.

⚠ WARNING

DO NOT REMOVE OR MODIFY SAFETY COVERS OR GUARDS.
Serious personal injury will result.

⚠ CAUTION

DO NOT POSITION ANY PART OF YOUR BODY
over the under-flow or over-flow box while operating.

MAC JR 1200E

Description, Care and Maintenance

Valves on the M2-922 Mixer

Mounted on the M2-922 mixer are 2 valves that have been reconfigured for use with the MAC JR 1200 and are not explained properly in the enclosed M2-922 Operators Manual. The following is the correct description for their use with the MAC JR 1200 unit.

Mounted on discharge outlet of the M2-922 pump is a 3-way valve labeled “A” (Fig.12a) . This valve is used to route the fluid discharge from the centrifugal pump to flow through the piping on the M2-922 mixer or when rotated, routes the fluid flow to valve “B”. *It should also be noted that in the M2-922 operators manual a second 3-way valve was located under this valve and attached to the pump suction inlet. This valve has been removed on the MAC JR 1200.*

Mounted on the bottom of the M2-922 mixer filter/shear is a valve used to route fluid to the “Mix” tank nozzles (Fig.12b). This valve is kept in the open position except if a system repair is needed, then it is closed to stop any fluid from the “Mix” tank siphoning back into the M2-922 mixer piping.

It should also be noted that in the M2-922 operators manual a second valve was located beside this valve on the filter/shear. It has now been removed and the outlet capped



**3-way valve
"A"**

(Valve shown in the Flow to Mixer position)

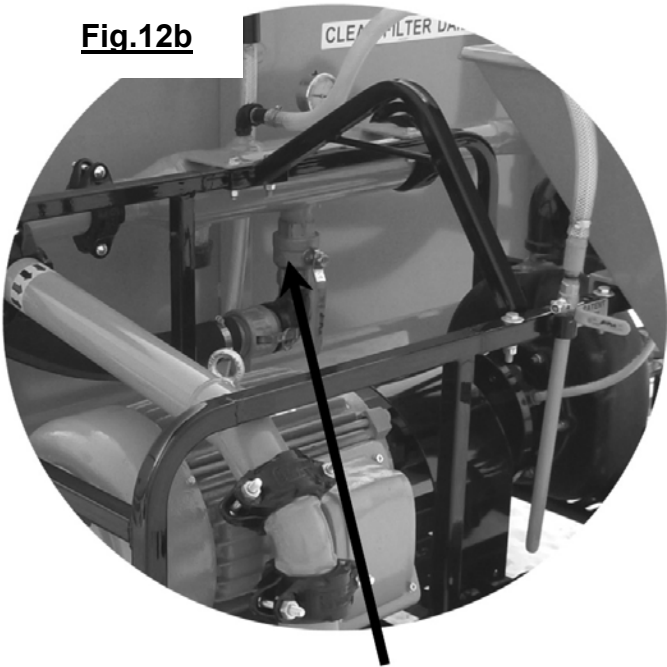

**"Mix" tank
nozzle valve**

(Valve shown in the open position)

SECTION #III

Set-up and Connection of Unit in Detail

MAC JR 1200E

Set-up and Connection of Unit in detail

Site Set-up (work mode)

A few general guidelines to follow when setting up a work site

- Set all equipment on flat level solid ground.
- Allow clear access around the MAC JR 1200.
- Keep all hoses as short as possible for better fluid flow
- Keep all hoses flat on the ground to avoid tripping hazards.
- READ and understand the operators manual(s) for ALL pieces of equipment used.
- Do Not move unit with the hoses connected.

Once the MAC JR 1200 unit has been positioned on site by a towing device, the unit is to be disconnected from the towing device, by blocking the wheels to stop any movement, and lowering the front jack to take the weight off of the hitch. The hitch can now be uncoupled, and the towing device can be moved away.

The transport locking pin in the tongue is removed, and the tongue is slid back into the skid frame. The transport locking pin can be stored in the hole in the tongue closest to the hitch.

Lower the back corner jacks to the ground and then, using both jacks, raise the unit approx. 2” higher. This will take the weight off of the wheel’s rotating arm and sliding lock plate. The sliding lock plate can be slid back onto the rotating arm thus disengaging the plate from under the skid frame gusset.

Using the back corner jacks, lower the unit to the ground. Go to the front jack and lower the unit to the ground.

Using a level measuring device, level the unit in all directions. Keep the unit touching the ground were ever possible by using only 2 jacks to level. **THE UNIT SHOULD NEVER BE COMPLETELY LIFTED OFF OF THE GROUND** with all 3 jacks when leveling. When the unit is filled with fluid the jacks may collapse or the unit may sustain structural damage.

Once the unit is leveled the hose connections can be made. (Fig.11)

Hose inlets and outlets are conveniently located on both sides of the unit for the use of shorter hoses, better hose routing, and a cleaner and safer work area.

TRANSPORT MODE

Fig.10a



Rotating arm down.
Sliding lock plate fully under base frame gussett.

WORK MODE

Fig.10b



Rotating arm up.
Sliding lock plate removed from under base frame gussett.

 DANGER
<p>NEVER ATTEMPT TO PUT THE UNIT INTO OPERATION</p> <p>without lowering the unit to the ground and leveling with the jacks. Serious personal injury will result.</p>

 WARNING	<p>REFER TO THE SAFETY STATEMENTS IN THE OEM MANUALS SUPPLIED AND THIS MANUAL REGARDING THESE OPERATIONS.</p>
--	---



MAC JR 1200E

Set-up and Connection of Unit in detail

Fig.11

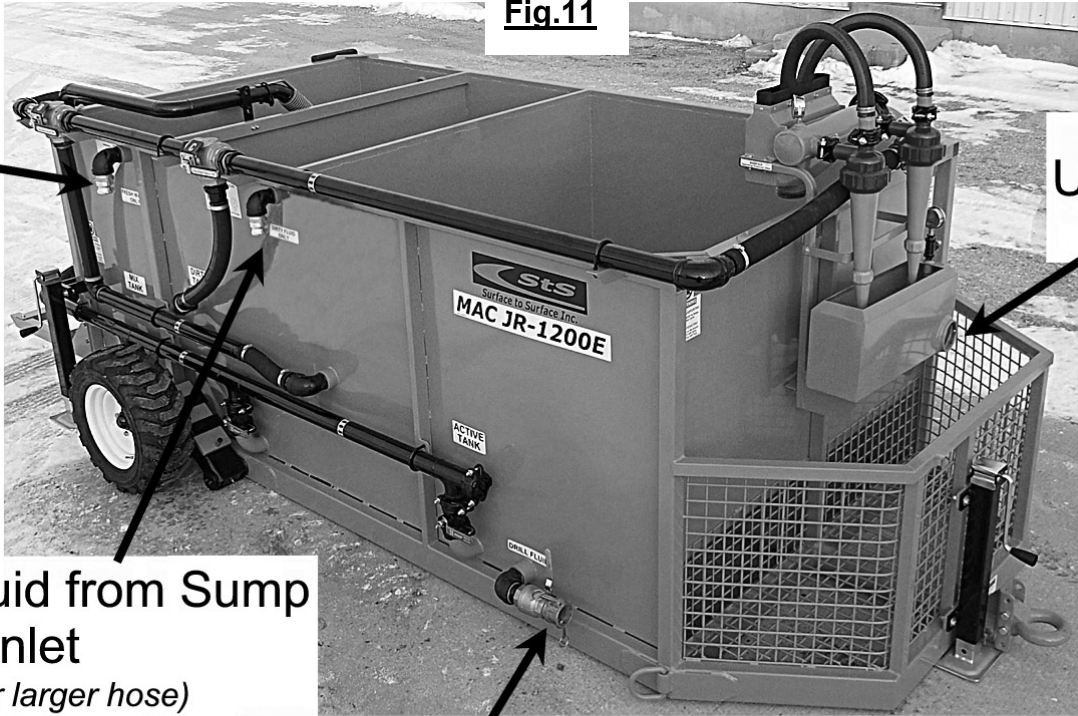

Fresh Water Inlet
(2" or larger hose)

Under-flow Waste Outlet
(3" or larger hose)

"Dirty" Fluid from Sump Inlet
(2" or larger hose)

Drill Fluid Outlet
(2" or larger hose)

MAC JR 1200 Shown in Work Mode
*All hoses to be kept as short as possible
Unit is on the ground and leveled.*

⚠ DANGER

NEVER ATTEMPT TO PUT THE UNIT INTO OPERATION
without lowering the unit to the ground and leveling with the jacks.
Serious personal injury will result.

MAC JR 1200E

Set-up and Connection of Unit in detail

Site Tear Down (Transport mode)

When the MAC JR 1200 is needed to change locations, a towing device will be required. **ALL FLUID MUST BE REMOVED FROM ALL TANKS.** Drain and disconnect all hoses that were connected to the unit. Using both back corner jacks, raise the unit up (approx. 12”), until the rotating arm and sliding lock plate are below the base frame gusset . The sliding lock plate can now be slid under the base frame gusset. The end of the sliding lock plate will extend beyond the base frame gusset when properly engaged (Fig.10a). Lower the rear corner jacks until the base frame gusset rests on top of the sliding lock plate. Now raise the rear corner jacks all the way to the top position where they will not get caught or bent while traveling. Go to the front jack and raise the unit up to the height required for the towing device. Pull (extend) the tongue all the way forward until the hole in the tongue is past the base skid. Install the transport locking pin into the hole and use the safety clip on the pin so it can not fall out (Fig.12). Connect the towing device to the tongue hitch and raise the front jack all the way to the top position where they will not get caught or bent while traveling. The unit is now ready for transporting.

Fig.12

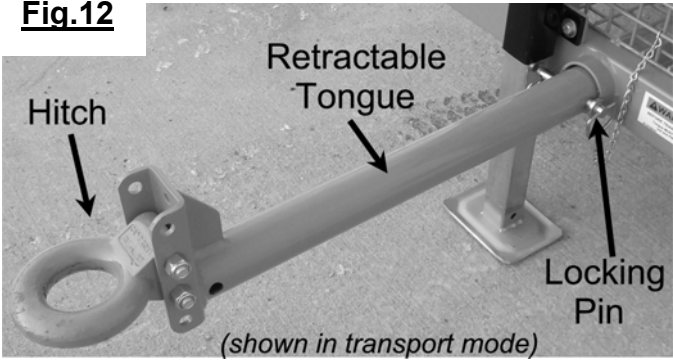

 DANGER
<p>NEVER TRANSPORT the unit without the wheel locks engaged in the transport position, the tongue extended and pinned and the leveling jacks fully retracted.</p>

 WARNING
<p>BEFORE TRANSPORTING</p> <ul style="list-style-type: none"> - ALL Tanks MUST be Empty. - SECURE Wheel Locks
<p>BEFORE OPERATING</p> <ul style="list-style-type: none"> - Unit MUST be on the ground and LEVELED with jacks, BEFORE Filling with fluid

MT-3X1500-54

SECTION #IV

Operating the MAC JR 1200 Unit



MAC JR 1200E

Operating the MAC JR 1200 Unit

Site Setup & Pre-Check

SITE SETUP

- **POSITION** the unit to have a clear unobstructed working area on all 4 sides.
- **POSITION** the unit on solid level surface to avoid settling or upset.
- **BLOCK** wheels to prevent movement.
- **DISCONNECT** from transporting device.
- **LOWER** the unit to ground level.
- **LEVEL** the unit in all directions.
- **CONNECT** and secure all hoses onto the unit according to your layout.
- **PROTECT** all hoses from possible damage or from being driven upon by a vehicle.

UNIT PRE-CHECK

- **READ and UNDERSTAND** the operators manual for the M2-922 mixer for proper pre-check, starting and running procedures.
- **CHECK** inside all of the tanks that they are clean and free of foreign materials.
- **CHECK** the “Mixing Tank” suction valve is open and all other suction valves are closed.
- **CHECK** to ensure there is sufficient water in the “Mixing Tank” to insure the centrifugal pump does not run dry.
- **CHECK** to ensure the ball valve on the M2-922 mixer filter shear connected to the “internal tank nozzles” is open.
- **CHECK** the 3-way valve “A” on the M2-922 is in the “Flow to mixer” position.
- **CHECK** the 3-way valve “B” is set to “Flow to active tank nozzles”.
- **CHECK** the 3-way valve “C” is set to “Flow to dirty tank nozzles”.
- **CHECK** the hydro-cyclone hoses (canes) are positioned into the over-flow box properly.
- **CHECK** the hydro-cyclones are vertical and the under-flow apex is inside of the box.
- **CHECK** the under-flow box hose is routed below the under-flow box outlet.

CAUTION
<p>The manufacturer should be consulted when considering alternative uses for this piece of equipment.</p> <p>This unit was designed for the mixing, cleaning and storing of drilling fluid. Other uses may create unforeseen safety issues and personal injury risk.</p>

	WARNING
	<p>REFER TO THE SAFETY STATEMENTS IN THE OEM MANUALS SUPPLIED AND THIS MANUAL REGARDING THESE OPERATIONS.</p>



MAC JR 1200E

Operating the MAC JR 1200 Unit

Mixing New Drill Fluid

The M2-922 Operators Manual (included separately) must be read and understood before using this piece of equipment!

Mixing Operation

With the “Mix” tank full of fresh water-

- Close the “Dirty” tank suction valve.
- Close the “Active” tank suction valve.
- Open the “Mix” tank suction valve.
- Rotate the 3-way valve “A” to position “Flow to mixer”.
- Open the “Mix” tank nozzle valve located on the bottom of the M2-922 mixer filter/shear (Fig.9b).
- With the pump full of liquid (primed), switch the M2-922 mixer motor ON.
- Open the hopper valve at the bottom of hopper where it joins the venturi mixing tee.
- Introduce the dry or liquid raw material into the hopper.

When mixing a new batch, introduce the 1st bag of dry product at a rate of 40 lbs. per minute. Once the first 40 lbs. of dry product are in the fluid stream, all dry products may be introduced as fast as the hopper will allow. This allows time for the 1st bag to be mixed well into the fluid and will now aid to suspend all remaining dry product that is added, in the fluid in the tank to achieve a better shear and stop any build-up in the tank.

- Suction created by the venturi mixing tee will draw the raw material into the jet stream for initial mixing.
- Flush jetting tee with wash wand.
- Close the butterfly valve on the hopper to keep debris out of the system.
- Allow the mixing system to circulate the product until the desired consistency is attained.
- A sample of the mixed fluid may be taken at from the wash wand as described in the M2-922 operators manual, on the wash wand description page.

 DANGER

IN AN EMERGENCY

STOP the mixer / pumping unit to halt the pump, and fluid flow

 CAUTION

WHEN THE UNIT IS IN OPERATION,

the fluid in the piping and hoses may reach pressures up to 50 p.s.i.

CAUTION

BEFORE STARTING OR RESTARTING the mixer, make sure the suction valve on the proper tank is open, and the fluid level in the tank is above the suction port.

 WARNING



REFER TO THE SAFETY STATEMENTS IN THE OEM MANUALS SUPPLIED AND THIS MANUAL REGARDING THESE OPERATIONS.



MAC JR 1200E

Operating the MAC JR 1200 Unit

Transferring New Drill Fluid to Active Tank

Transferring New Drilling Fluid to Active Tank

- Switch the M2-922 mixer motor OFF.
- Rotate the 3-way valve “A” to position “Flow to valve B”.
- Rotate the 3-way valve “B” to position “Flow to active tank nozzles”.
- Switch the M2-922 mixer motor ON.
The new fluid will be pumped into the “Active” tank thru the nozzles, from the “Mix” tank.
- When the “Mix” Tank is empty, or the pump sucks air (cavitation) switch the M2-922 mixer motor OFF.

Note: it is common for some fluid to remain in the “Mix” tank.

- Switch the M2-922 mixer motor OFF.
 - Rotate the 3-way valve “A” to position “Flow to valve Mixer”.
 - Leave the 3-way valve “B” to position “Flow to active tank nozzles”.
- You are now ready to mix another batch of new drilling fluid.*

The “Active” tank will hold 2 batches of new drilling fluid and an extra batch can be made and held in the “Mix” tank until needed without interfering with the remaining operations of the MAC JR 1200 system.

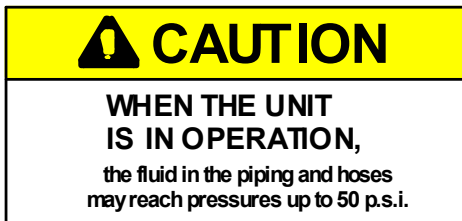
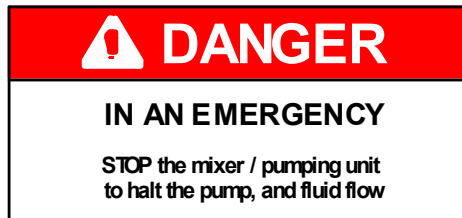



MAC JR 1200E

Operating the MAC JR 1200 Unit

Agitating the Active Tank

Agitating the Fluid in the Active Tank

- Switch the M2-922 mixer motor OFF.
- Close the “Mix” tank suction valve.
- Open the “Active” tank suction valve.
- Rotate the 3-way valve “A” to position “Flow to valve B”.
- Rotate the 3-way valve “B” to position “Flow to active tank nozzles”.
- Switch the M2-922 mixer motor ON.

The M2-922 mixer will now draw the fluid from the “Active” tank and return it back to the “Active” tank thru the nozzle keeping the fluid in the tank rolling.

 DANGER
IN AN EMERGENCY
STOP the mixer / pumping unit to halt the pump, and fluid flow

 CAUTION
WHEN THE UNIT IS IN OPERATION,
the fluid in the piping and hoses may reach pressures up to 50 p.s.i.

CAUTION
BEFORE STARTING OR RESTARTING
the mixer, make sure the suction valve on the proper tank is open, and the fluid level in the tank is above the suction port.



MAC JR 1200E

Operating the MAC JR 1200 Unit

Cleaning the Dirty Fluid for Reuse

Cleaning the “Dirty” Fluid for reuse

The “Dirty” fluid tank is now full of dirty fluid from your sump (customer supplied pump) and it is now ready to be “Cleaned” with the hydro-cyclones mounted at the front of the MAC JR 1200, to be reused.

- Switch the M2-922 mixer motor OFF.
- Close the “Mix” tank suction valve.
- Close the “Active” tank suction valve.
- Open the “Dirty” tank suction valve.
- Rotate the 3-way valve “A” to position “Flow to valve B”.
- Rotate the 3-way valve “B” to position “Flow to valve C”.
- Rotate the 3-way valve “C” to position “Flow to dirty tank nozzles”.
- Switch the M2-922 mixer motor ON.

The M2-922 mixer will now draw the fluid from the “Dirty” tank and return it back to the “Dirty” tank thru the nozzles keeping the dirty fluid in the tank rolling to reduce any sediment.

- Let the dirty tank roll and mix up for 5 to 10 minutes.
- Watch the pressure gauge on the hydro-cyclone manifold.
- **SLOWLY** rotate the 3-way valve “C” downward toward position “Flow to cone head” and **STOP ROTATING WHEN THE PRESSURE GAUGE IS AT 32PSI.**

CAUTION: Excessive fluid pressure WILL damage the hydro-cyclones.

The M2-922 mixer is now drawing the fluid from the “Dirty” tank and routing enough fluid to create 32psi at the cone manifold, thru the hydro-cyclones, and the remaining dirty fluid is returned back to the “Dirty” tank thru the nozzles, keeping the dirty fluid in the tank rolling to reduce any sediment.

The cleaned fluid will flow from the over-flow box down into the active tank to be reused.

The “Solids” from the underflow box will flow out of the front discharge port of the box.

Refer back to section II Fig.9b about how the hydro-cyclones operate.

- When the “Dirty” Tank is empty, or the pump sucks air (cavitation) switch the M2-922 mixer motor OFF.
- Note:** it is common for some fluid to remain in the “Dirty” tank.
- Switch the M2-922 mixer motor OFF.
 - Rotate the 3-way valve “C” to position “Flow to Dirty Tank Nozzles”.

DANGER
IN AN EMERGENCY
STOP the mixer / pumping unit to halt the pump, and fluid flow

WARNING
NEVER ATTEMPT TO REMOVE OR CLEAN THE HYDRO-CYCLONES
while the unit is in operation. Serious personal injury will result.

CAUTION
DO NOT POSITION ANY PART OF YOUR BODY
over the under-flow or over-flow box while operating.



MAC JR 1200E

Operating the MAC JR 1200 Unit

Warm Weather Shutdown & Storage

Daily Shut Down

- Follow “Daily Shut Down Instructions” in the M2-922 operators manual to shut down the mixer.
- If tanks are empty, load some fresh water (100gal) into the mix tank and pump fresh water through the piping from tank to tank then suck all water back into the mix tank for reuse.
- Close all suction valves.
- If fluid is left in the “Mix” tank, rotate the “Mix” tank nozzle valve to the closed position.
- Close the “Drill Fluid” valve on the “Active” tank.
- Remove, clean, reinstall the screening basket on the inlet port of the middle “Dirty” tank.
- Rinse out the over-flow box with clear water.
- Rinse out the under-flow boxes with clear water.

Additional Week End Shut Down

- Follow “Week End Shut Down Instructions” in the M2-922 operators manual to shut down the mixer.
- Follow “Daily Shut Down” (above).
- Remove the cone manifold removable inlet end cap and rinse the inside of the manifold. Replace end cap.

CAUTION
CARE MUST BE TAKEN WHEN CONNECTING THE HOSE COUPLINGS. The faces must be clean before mating together. Rotate body to engage lock.

CAUTION
CARE MUST BE TAKEN WHEN INSTALLING THE COUPLER GASKETS. If the gaskets are not properly lubricated and installed, a leak may develop.

CAUTION
TRAPPED FLUID MAY BE PRESENT and will spill out when piping or hoses are removed.

	WARNING
	REFER TO THE SAFETY STATEMENTS IN THE OEM MANUALS SUPPLIED AND THIS MANUAL REGARDING THESE OPERATIONS.



MAC JR 1200E

Operating the MAC JR 1200 Unit

Cold Weather Shutdown & Storage

Additional Winter and Freezing Weather Shut Down

Note: *all fluid is to be dispose of according to local environmental approved practices.*

- Follow “Additional Winter and Freezing Weather Shut Down Instructions” in the M2-922 operators manual.
- Drain all fluid out of the tanks.
- Rotate the “Mix” tank nozzle valve to the open position.
- Remove suction manifold end cap and drain fluid from manifold.
- Open all suction valves.
- Set 3-way valves “A”, “B”, “C” at half of rotation (1/2 way between valve handle stops).
- Disconnect all 2” hose quick couplers that connect the mixer to the 2” external piping.
- Disconnect the hose from the drilling rig to the “Drilling Fluid” valve on the “Active” tank.
- Open the “Drill Fluid” valve on the “Active” tank.
- Disconnect the 2” hose quick coupler that connect the cone manifold to the 2” external piping.
- Remove the cone manifold removable inlet end cap and rinse the inside of the manifold. Leave the end cap off.
- Rinse out the over-flow box and over-flow discharge with clear water.
- Rinse out the under-flow boxes with clear water.
- Disconnect the hose on the underflow box outlet.
- Disconnect any hoses connected to the “Mix” tank, and “Dirty” tank inlets.
- Remove, clean, reinstall the screening basket on the inlet port of the middle “Dirty” tank.
- If possible, raise (jack) the unit up on one side, to allow any fluid remaining in the tank to flow away from the tank suction ports.

CAUTION
<p>NEVER LEAVE LIQUID IN THE PIPING, HOSES OR TANK during freezing weather conditions, as damage will result. Follow instruction for winterizing.</p>

	WARNING
	<p>REFER TO THE SAFETY STATEMENTS IN THE OEM MANUALS SUPPLIED AND THIS MANUAL REGARDING THESE OPERATIONS.</p>



MAC JR 1200E

Operating the MAC JR 1200 Unit

Prolonged Periods of Storage

Prolonged Periods of Storage

- Follow “ Prolonged Periods of Storage Instructions” in the M2-922 operators manual.

After a thorough cleaning of the internal and external components of the MAC JR 1200, the following steps should be applied to extend the life of your unit.

- Spray all valves and 2” quick couplers with an oil base lube/protectant.
- Grease & lubricate the rotating arm (with spindle hub & wheel) and sliding lock plate

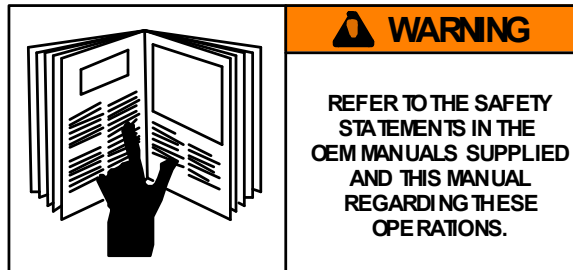

SECTION #V

Troubleshooting the MAC JR 1200 Unit



MAC JR 1200E

Troubleshooting the MAC JR 1200 Unit

The MAC JR 1200 is used in conjunction with the M2-922 mixer. The M2-922 mixer has its own operators manual with a trouble-shooting section and should be referred to when there is a problem with the M2-922 mixing abilities.

This section of the manual deals with the MAC JR 1200 unit on its own.

The MAC JR 1200 is made up of 3 tanks mounted onto a portable skid, with external piping and valves. Fluid is mixed and stored in the tanks and moved from tank to tank via the external piping and valves. Mounted on the front of the unit is an assembly where the “Dirty” drill fluid is routed to and processed through the hydro-cyclones to remove cuttings, and give a suitable fluid for reuse in the drilling process. The MAC JR 1200 unit is of a simple design with limited moving parts or consumable pieces.

The following, may aid in any problems that may arise.

Always check that the pump on the M2-922 is primed and functioning properly

- *No fluid to the M2-922 mixer.*
“Mix” tank suction valve closed. - Open suction valve.

- *“Mix” tank does not have a rolling action of the fluid.*
“Mix” tank nozzle valve closed. - Open valve.

- *Cannot transfer fluid to “Active” tank.*
3-way valve(s) closed or in incorrect position - Open or reposition valves (see section IV).
“Mix” tank suction valve closed - Open valve.

- *“Active” tank does not have a rolling action of the fluid.*
3-way valve(s) closed or in incorrect position - Open or reposition valves (see section IV).
“Active” tank suction valve closed - Open valve.

- *“Dirty” tank does not have a rolling action of the fluid.*
3-way valve(s) closed or in incorrect position - Open or reposition valves (see section IV).
“Dirty” tank suction valve closed - Open valve.
Fluid too thick to pump. - Thin fluid by adding more water.
“Dirty” tank nozzles plugged – Clean manifold and nozzles.

- *No fluid flow/ low fluid flow to the cone manifold*
M2-922 not pumping fluid. - See M2-922 Operators manual.
3-way valve(s) closed or in incorrect position - Open or reposition valves (see section IV).
“Dirty” tank suction valve closed - Open valve.
Not enough fluid in the “Dirty” tank - Add fluid or shutdown.
Cone manifold plugged. - Clean out manifold.
Fluid too thick to pump. - Thin fluid by adding more water.

- *No manifold pressure / low manifold pressure.*
No fluid flow / low fluid flow - See above solutions.
Pressure gauge not working - Clean or replace pressure gauge.
Hydro-cyclone(s) wore out. - Replace apex or complete cone(s).



MAC JR 1200E

Troubleshooting the MAC JR 1200 Unit *continued*

- *High manifold pressure.*
 - Valve “C” open to far. - Readjust valve.**
 - Hydro-cyclone(s) plugged. - Shutdown system and unplug cone(s).**
 - Manifold to cone outlet plugged. – Remove blockage.**
- *Hydro-cyclone discharge irregular or roping.*
 - Incorrect manifold pressure. - See previous solutions.**
 - To high of a solids content in fluid. - Add water to “Dirty” tank.**
 - Hydro-cyclone(s) wore out. - Replace apex or complete cone(s).**
- *Over-flow box has excessive overspray out of top.*
 - Cone hose (cane) not in center position. - Place hose back into proper position see Fig.7b.**
- *Over-flow box is overflowing.*
 - Over-flow box outlet is plugged. - Remove blockage.**
- *Under-flow box is overflowing.*
 - Under-flow box outlet has buildup / blockage under weir plate.. - Remove blockage.**
 - Under-flow box outlet has a hose attached that restricted flow. – Change routing, length, or size.**
 - MAC JR 1200 is not level. – Level unit.**
- *Over-flow fluid does not meet reduced solids spec.(too dirty)*
 - Incorrect manifold pressure. - See previous solutions.**
 - To high of a solids content in fluid. - Add water to “Dirty” tank.**
 - Hydro-cyclone(s) wore out. - Replace apex or complete cone(s).**

**For problems that cannot be solved by the above steps,
call your local distributor or STSI (1-800-567-0978) and talk to a company representative
who would be glad to assist you with your problem.**

SECTION #VI

Periodic Maintenance & Repair Information



MAC JR 1200E Electric Periodic Maintenance Schedule

Maintenance Items <i>MAC JR 1200 Components</i>	Before Use	Every 8 hours (daily)	Every 50 hours (weekly)	Every 200 hours (monthly)	Every 1000 hours	Every 2000 hours (or yearly)
Visual check of base skid and structure for damage.		●				
Visual check of D-rings (before using).	●					
Visual check leveling jacks for damage.	●					
Check wheel lug bolts loose, broken, missing.	●					
Check tongue hitch for damage or wear.	●					
Check sliding lock plate for damage or wear.		●				
Check / Clean tanks for sediment or debris.	●					
Check hoses and connections for damage, wear, cracks.		●				
Check clamps are tight and safety pins installed.		●				
Clean "Dirty Tank" screening basket.		●				
Flush piping and valves with clear water.		●				
Check hydro-cyclone body nut & apex are tight.		●				
Check hydro-cyclones are vertical.		●				
Check hydro-cyclone hoses (canes) are centered in box.		●				
Clean under-flow & over-flow box of build-up.		●				
Remove end cap from cone manifold and clean.				●		
Check Hydro-cyclones for excessive wear (internal.)					●	
Check air pressure in tires.			●			
Grease rotating arm.				●		
Check wheel bearings.						●
Remove top of leveling jacks and grease internally.					●	

STSI is not to be held liable for any discrepancies or errors in the above schedule

MAC JR 1200E

Bolt Torque Specifications

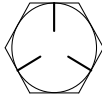

Grade 5

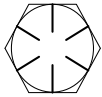

Grade 8

SAE SIZE	Lubricated *		Dry **	
	N.m	ft-lbs	N.m	ft-lbs
1/4	9.5	7	12	9
5/16	20	15	25	18
3/8	35	26	44	33
7/16	55	41	70	52
1/2	85	63	110	80
9/16	125	90	155	115
5/8	170	125	215	160
3/4	300	225	375	280
7/8	490	360	625	450
1	725	540	925	675

Lubricated *		Dry **	
N.m	ft-lbs	N.m	ft-lbs
13.5	10	17	12.5
28	21	35	26
50	36	63	46
80	58	100	75
120	90	150	115
175	130	225	160
215	160	300	225
425	310	550	400
700	500	875	650
1050	750	1300	975

* "Lubricated" means coated with a lubricant such as engine oil, or fasteners with phosphate and oil coatings.

** "Dry" means plain or zinc plated without any lubrication.

Metric size

Thread size x pitch mm	N.m	ft-lbs
M6 X 1.0	10.8 ± 1.0	8.0 ± 0.5
M8 x 1.25	25.5 ± 2.9	19.0 ± 2.0
M10 x 1.5	49.0 ± 4.9	36.0 ± 4.0
M12 x 1.75	88.3 ± 9.8	65.0 ± 7.0
M14 x 1.5	137.0 ± 9.8	101.0 ± 7.0
M16 x 1.5	226.0 ± 9.8	167.0 ± 7.0

Apply 60% torque to bolts that are not listed.

Apply 80% torque when tightened to aluminum alloy.

SECTION #VII

OEM Repair Information

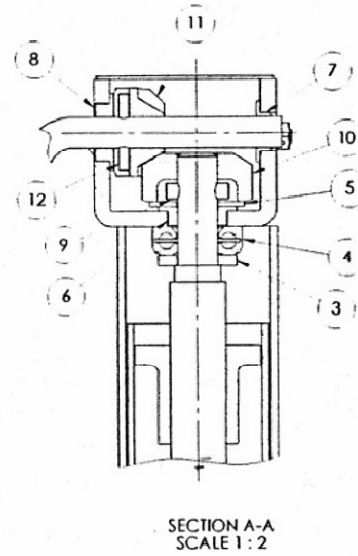
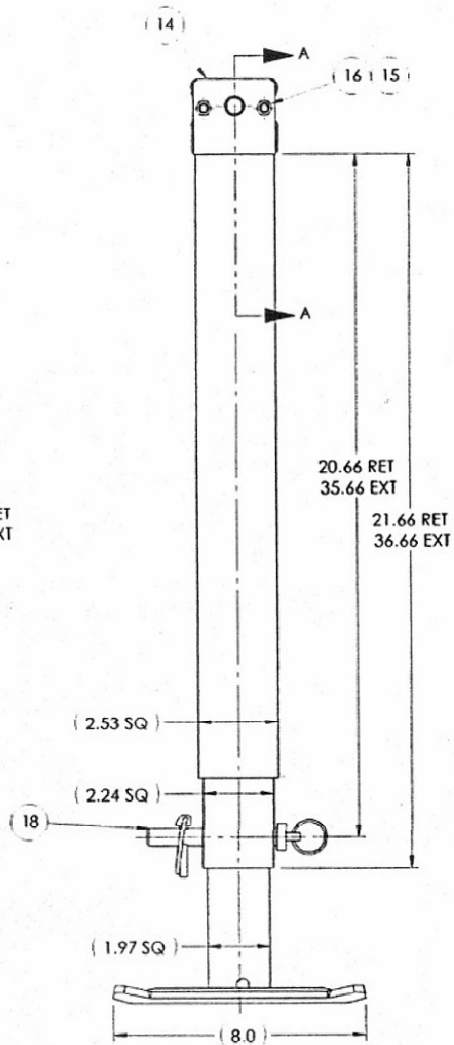
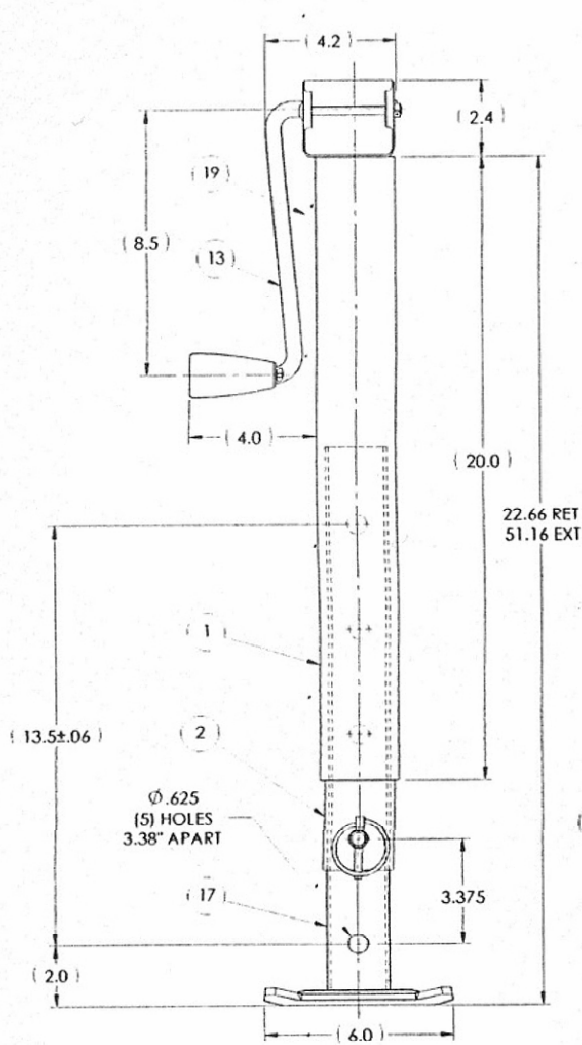

ITEM	PART NO.	DESCRIPTION	QTY.
1	709458	OUTER TUBE & GRBX-20" WLD	1
2	710631	INNER TUBE/S&N ASSY	1
3	016146	WASHER, SUPPORT 5K SQ. .179 THK.	1
4	001020	THRUST BEARING	1
5	016135	WASHER, .08" X .631" ID - HT TRTD	1
6	021273	BUSHING, PM .630" ID. HEX	1
7	017011	BUSHING, FLANGE	1
8	021277	BUSHING, HEX	1
9	009129	DOWEL PIN, 1/4" X 1.00" LG.	1
10	020043	BEVEL GEAR	1
11	020012	PINION GEAR	1
12	009008	GROOVE PIN, 5/32"	1
13	700380	CRANK, SW ASSY - 8.5	1
14	016041	COVER, GEARBOX	1
15	002011	BOLT, 1/4-20X3.12" CARR	2
16	008002	NUT, 1/4-20 HEX LOCK	2
17	701340	DROP LEG ASSY-17.5" WLD	1
18	701472	PULL PIN ASSY	1
19	F3343	LABEL, BULLDOG CAPACITY 5/8K	1

B

OUTER TUBE - 20.0"
 FINISH -76 PRIME FINISH, GRAY SPRAY
 INNER TUBE - 21.38"
 FINISH -01 CLEAR ZINC
 DROPLEG - 17.5"
 FINISH -01 CLEAR ZINC
 SCREW - 7/8-8 X 18.72"
 TRAVEL - 15.0"
 CAPACITY
 STATIC- 8000 LBS.
 LIFT- 5000 LBS.



e-mail: pwestmkt@mts.net

website: www.pointswestmarketing.com

84 De Baets Street
 Winnipeg, Manitoba
 Canada R2J 3S9
 Phone: (204) 661-8111
 FAX: (204) 663-9279

DRAWING NUMBER	REVISED BY
190754	B

Jack Style #1

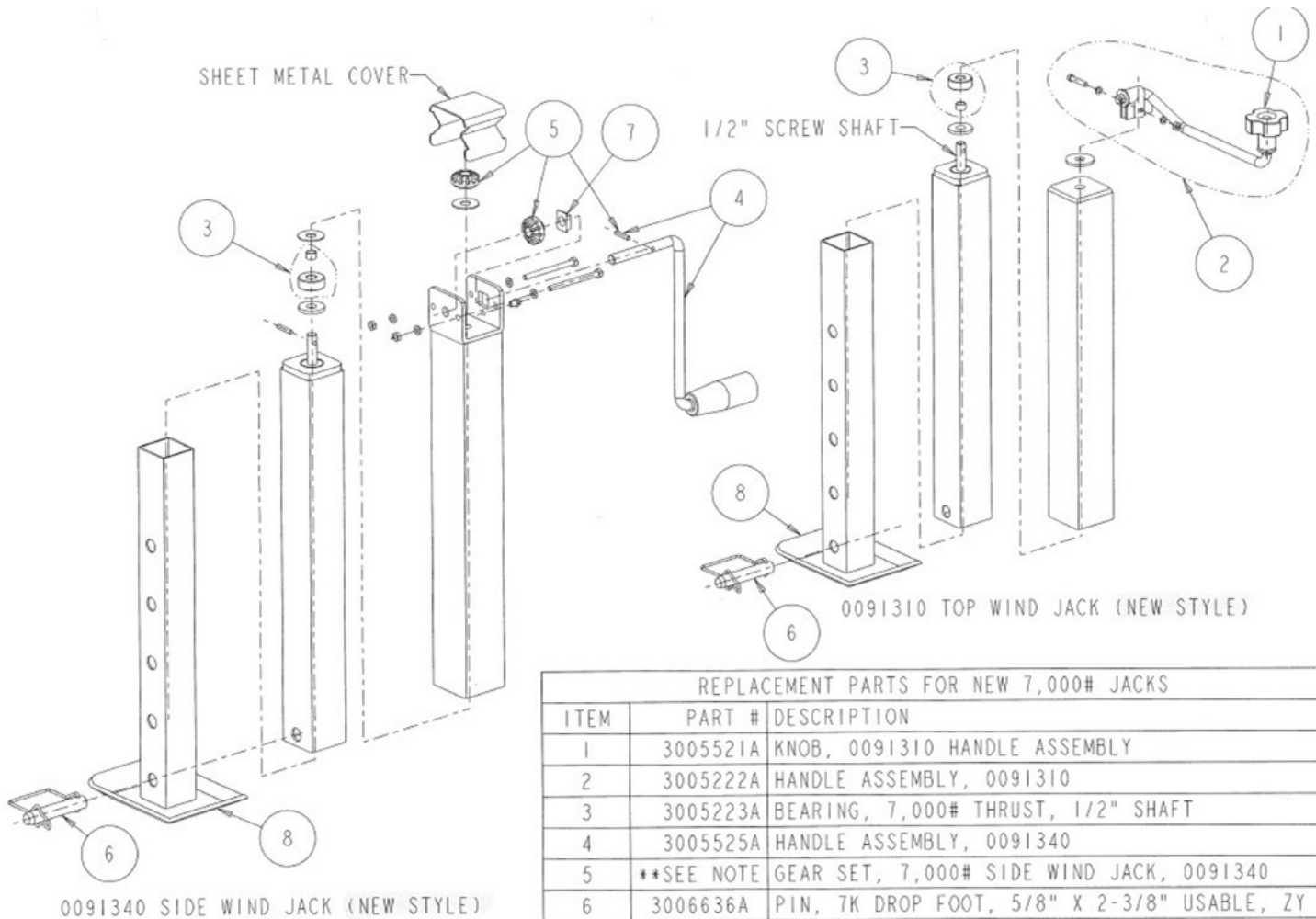

REPLACEMENT PARTS FOR NEW 7,000# JACKS		
ITEM	PART #	DESCRIPTION
1	3005521A	KNOB, 0091310 HANDLE ASSEMBLY
2	3005222A	HANDLE ASSEMBLY, 0091310
3	3005223A	BEARING, 7,000# THRUST, 1/2" SHAFT
4	3005525A	HANDLE ASSEMBLY, 0091340
5	**SEE NOTE	GEAR SET, 7,000# SIDE WIND JACK, 0091340
6	3006636A	PIN, 7K DROP FOOT, 5/8" X 2-3/8" USABLE, ZY
7	3006742A	BUSHING, REPLACEMENT HANDLE, 0091340
8	3006073A	DROP FOOT, ONLY, 7K JACKS

**NOTE: SEE GEAR IDENTIFICATION DRAWING

0091340
NEW STYLE A

0091340
NEW STYLE B

3005527A GEAR SET
TWO GEARS, SAME SIZE
AND HANDLE PIN

3005527B GEAR SET
TWO GEARS, ONE LARGE, ONE SMALL
AND HANDLE PIN

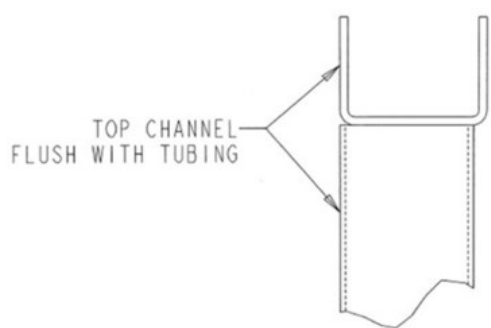
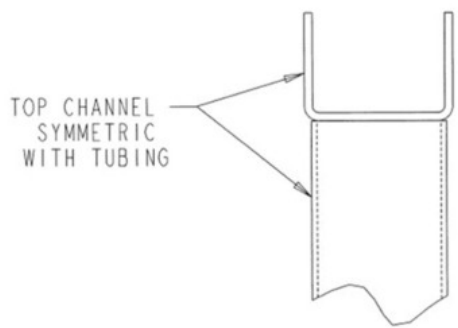

NOTE: ALL OTHER SERVICE PARTS REMAIN THE SAME

Jack Style #2

0091340_GEAR5

COUPLING INSTALLATION & ASSEMBLY

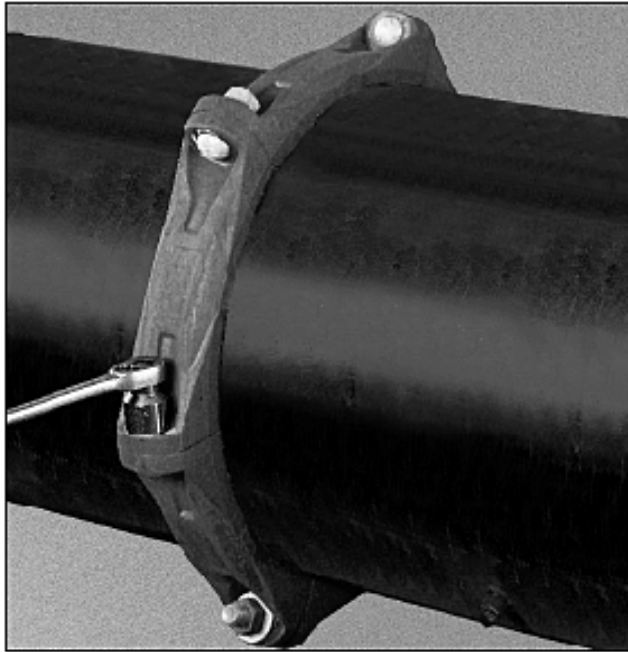

The instructions are based on pipe grooved in accordance with Gruvlok® grooving specifications. Check pipe ends for proper groove dimensions and to assure that the pipe ends are free of indentations and projections which would prevent proper sealing.

ALWAYS USE A GRUVLOK® LUBRICANT FOR PROPER COUPLING ASSEMBLY. Thorough lubrication of the external surface of the gasket is essential to prevent pinching and possible damage to the gasket. For temperatures above 150° F (65.6° C) use Gruvlok Xtreme™ Lubricant and lubricate all gasket surfaces, internal and external. See Gruvlok Lubricants in the Technical Data section of the Gruvlok catalog for additional important information.

SPECIFIED BOLT TORQUE

Specified bolt torque is for the oval neck track bolts used on Gruvlok® couplings and flanges. The nuts must be tightened alternately and evenly until fully tightened. Caution: Use of an impact wrench is not recommended because the torque output can vary significantly due to many variables including air pressure supply, battery strength and operational variations.

CAUTION: Proper torquing of coupling bolts is required to obtain specified performance. Over torquing the bolts may result in damage to the bolt and/or casting which could result in pipe joint separation. Under torquing the bolts may result in lower pressure retention capabilities, lower bend load capabilities, joint leakage and pipe joint separation. Pipe joint separation may result in significant property damage and serious injury.

ANSI SPECIFIED BOLT TORQUE		
Bolt Size	Wrench Size	Specified Bolt Torque *
<i>in.</i>	<i>in.</i>	<i>ft. lbs.</i>
3/8	9/16	30-45
1/2	3/4	80-140
5/8	1 1/8	100-130
3/4	1 1/4	130-180
7/8	1 5/8	180-220
1	1 3/4	200-250
1 1/8	1 7/8	225-275
1 1/4	2	250-300

* Non-lubricated bolt torques.

METRIC SPECIFIED BOLT TORQUE		
Bolt Size	Wrench Size	Specified Bolt Torque *
<i>mm</i>	<i>mm</i>	<i>N m</i>
M10	16	40-60
M12	22	110-150
M16	24	135-175
M20	30	175-245
M22	34	245-300
M24	36	270-340

* Non-lubricated bolt torques.

NOTE: Specified torques are to be used unless otherwise noted on product installation instructions.

FIG. 7000

Lightweight Flexible Coupling



1 CHECK & LUBRICATE GASKET— Check gasket to be sure it is compatible for the intended service. Apply a thin coating of GUVLOK lubricant to outside and sealing lips of the gasket. Be careful that foreign particles do not adhere to lubricated surfaces.



2 GASKET INSTALLATION— Slip the gasket over the pipe end, making sure the gasket lip does not overhang the pipe end.



3 ALIGNMENT— After aligning the two pipe ends together, pull the gasket into position, centering it between the grooves on each pipe. Gasket should not extend into the groove on either pipe.

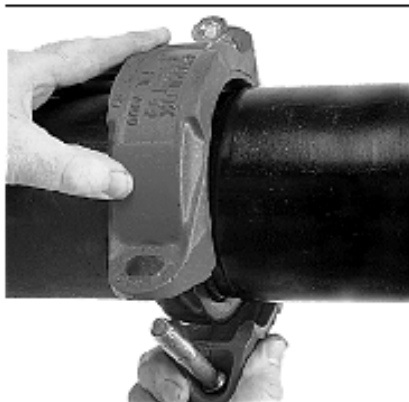

4 HOUSINGS— With one nut unthreaded to the end of the bolt, unthread the other nut completely and swing the coupling housing halves over the gasket, making sure the housing keys engage the grooves. Insert the bolt and turn the nuts finger tight.

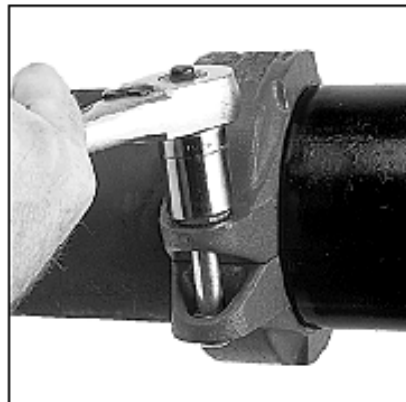

5 TIGHTEN NUTS— Tighten the nuts alternately and equally to the specified bolt torque. The housing bolt pads must make metal-to-metal contact.

CAUTION: Uneven tightening may cause the gasket to pinch.

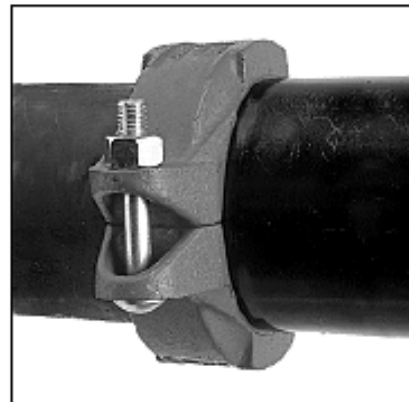

6 ASSEMBLY IS COMPLETE— Visually inspect the pipe joint to assure the coupling keys are fully engaged in the pipe grooves and the bolt pads are in firm even metal-to-metal contact on both sides of the coupling.

CAUTION: Use of an impact wrench is not recommended because the torque output can vary significantly due to many variables including air pressure supply, battery strength and operational variations.

CAUTION: Proper torquing of coupling bolts is required to obtain specified performance. Over torquing the bolts may result in damage to the bolt and/or casting which could result in pipe joint separation. Under torquing the bolts may result in lower pressure retention capabilities, lower bend load capabilities, joint leakage and pipe joint separation. Pipe joint separation may result in significant property damage and serious injury.

NOTE: VdS - Roll Grooving Approval Specifications, see the Technical Data/Installation Instructions section on Anvil's website - www.anvilintl.com

FIG. 7003 Hingelok™ Coupling

NOTE: Remove locking pin from handle before opening coupling.



1 CHECK & LUBRICATE GASKET— Check gasket to be sure it is compatible for the intended service. Apply a thin coating of GUVLOK lubricant to outside and sealing lips of the gasket. Be careful that foreign particles do not adhere to lubricated surfaces.



2 GASKET INSTALLATION— Slip the gasket over the pipe end making sure the gasket lip does not overhang the pipe end.



3 ALIGNMENT— After aligning the two pipe ends, pull the gasket into position centering it between the grooves on each pipe. Gasket should not extend into the groove on either pipe.



4 HOUSINGS— Put one half of the open coupling over the gasket as the coupling keys fit firmly into the grooves on each pipe end. Swing the other half of the coupling into position around the gasket and into the grooves.

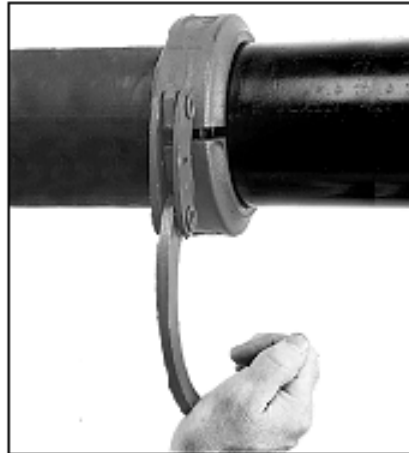

5 LOCK COUPLING— Fit the nose of the locking handle in the notch of the opposite housing. Press firmly down on the handle until it makes contact with the coupling housing. Insert locking pin into handle linkage to secure handle in closed position. (See Caution.)

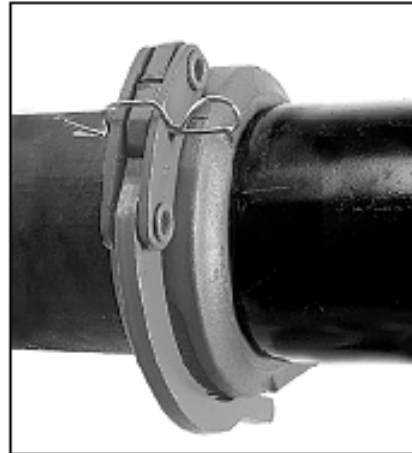

6 ASSEMBLY IS COMPLETE— Visually inspect the pipe joint to assure the coupling keys are fully engaged in the pipe grooves and the bolt pads are in firm even metal-to-metal contact on both sides of the coupling.

CAUTION:

- 1) Hammering or lancing on the handle or coupling housing could cause serious damage to the locking device and coupling assembly. The result may be an unsuitable pipe joint and unusable coupling assembly.
- 2) Care needs to be taken so that fingers do not get caught or pinched when handle is placed in locked position as a result of cam action of handle assembly.
- 3) When re-using coupling and gasket always inspect gasket for damage and hinge/handle assembly for looseness, distortion or any other damage.

SECTION #VIII

(Parts Manual)

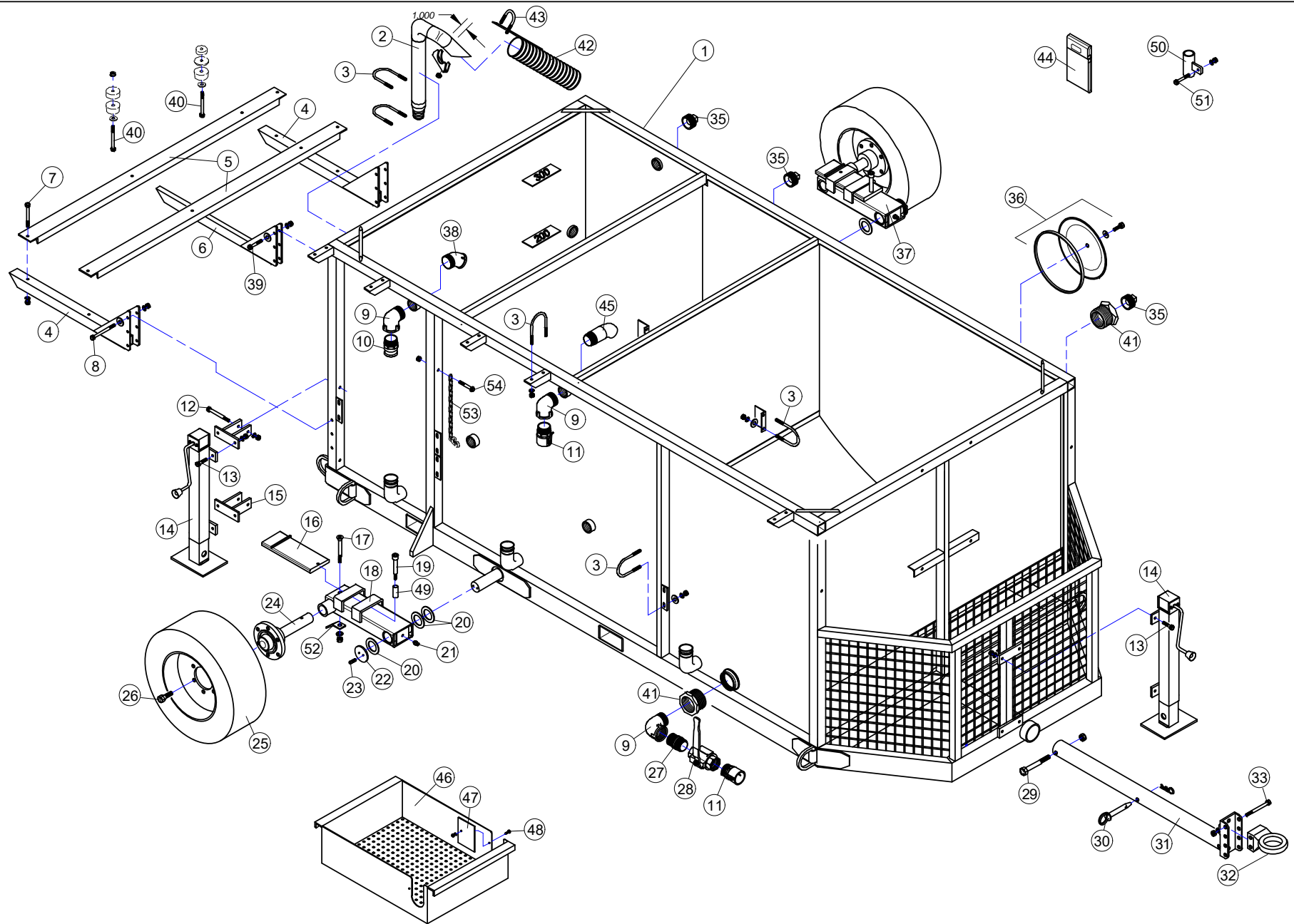

Total Weight without Mixer and NO options = 2500 lbs (March 11 2019)

Surface to Surface Inc.®	
DWR. NUM.	DATE. 11 / 23 / 12
MT3X1500-84	REV. 03 / 07 / 19

MAC JR 1200 ASSEMBLY PARTS LIST

REF #	DESCRIPTION	STS PART NUMBER	QTY REQ.	
1	Tank	MT-3X1500-03	1	O
2	Return Pipe	MT-3X1500-22	1	B
3	3/8" U-Bolt	076-42036	14	
	3/8" L/W	076-33622	14	
	3/8" F/W	076-33008	14	
	3/8" Nut	076-36306	14	
4	Mixer Mount Arm	MT-3X1500-14	2	O
5	Mixer Mount Crossbar	MT-3X1500-17-A	2	O
6	Mixer Mount Arm	MT-3X150016	1	O
7	7/16" x 3" Bolt	076-13165	4	
	7/16" L/W	076-33624	4	
	7/16" Nut	076-36308	4	
8	7/16" x 3 1/2" Bolt	076-131167	6	
	7/16" L/W	076-33624	6	
	3/8" F/W	076-33008	6	
	7/16" Nut	076-36308	6	
9	2" NPT 90° Street Elbow	018-310-01720-7	3	B
10	2" Male Cam-loc x Male NPT	025-200-F-AL	1	
11	2" Female Cam-loc x Male NPT	025-200-B-AL	2	
12	7/16" x 3 1/2" Bolt	076-13167	4	
	7/16" L/W	076-33624	4	
	7/16" Nut	076-36308	4	
13	7/16" x 1 1/2" Bolt	076-13159	12	
	7/16" L/W	076-33624	12	
	7/16" Nut	076-36308	12	
14	Leveling Jack	MT-3X1500-38	3	B
15	Leveling Jack Mount	MT-3X1500-39	4	B
16	Slide Lock	MT-3X1500-35	2	O
17	1/2" FHCS X 4" bolt	076-24371	2	
	1/2" L/W	076-33626	2	
	1/2" Nut	076-36310	2	
18	Wheel Link	MT-3X1500-30	1	B
19	1/2" x 1 1/2" Shoulder Bolt	076-74117	2	B
20	Spindle Spacer Washer	076-33496	6	B
21	1/8" NPT Grease Zert	036-60102	2	
22	Spindle Cap	MT-3X1500-12-E	2	B
23	5/16" NC x 3/4" SHCS	076-23255	4	
	5/16" high collar L/W	076-33687	4	
24	Wheel Spindle	MT-3X1500-36	2	B
25	TIRE (23/8.5 x 12 x 6 PLY)	085-23-8.5-12	2	
	RIM (6 x 12/6 on 6"BC)	085-W612-6	2	
26	Lug Bolt	c/w Spindle	12	
27	2" NPT x Close Nipple	018-033-037003	1	B
28	2" NPT Ball Valve	022-423-00014-0	1	
29	3/4" x 4" Bolt	076-13369	1	
	3/4" Stover Loc Nut	076-37274	1	
30	3/4" x 4 1/4" Draw Pin c/w Clip	076-0157184	1	
31	Removable Tongue	MT-3X1500-07	1	O
32	Pinto Hitch Ring	085-4200130-BRK	1	O

33	5/8" x 4 1/2" Bolt	076-13321	2	
	5/8" Stover Loc Nut	076-37272	2	
34				
35	2" NPT Cored Pipe Plug	018-318090256-6	5	B
36	Clean-out Cover	086-TL-EC-12	3	O
	Rubber Gasket	086-TL-EC6-12	3	
	Plastic Washer	086-TLEC-W	3	
	5/8" x 1 1/2" Bolt	076-13309	3	
37	Wheel Link	MT-3X1500-32	1	B
38	2" NPT 45° Street Elbow	018-310-02820-4	2	B
39	7/16" x 2 1/2" Bolt	076-13163	3	
	7/16" L/W	076-33624	3	
	3/8" F/W	076-33008	3	
	7/16" Nut	076-36308	3	
40	5/16" x 3" Bolt	076-13065	4	
41	3" NPT x 2" NPT Pipe Bushing	018-318-90828-2	2	B
42	Return Pipe Cover Hose	#MT-3X1500-43	1	B
43	2 1/2" Exhaust Clamp	031-MC 7212-050	1	B
44	Operators Manual Holder	084-9000-07	1	
45	Dirty Tank Inlet Pipe	MT-3X1500-214	1	B
46	Pre-Screen Basket	MT-3X1500-210	1	
47	Pre-Screen Basket Cover	MT-3X1500-211-B	1	
48	1/4" x 3/4" Bolt	076-13003	1	
	1/4" L/W	076-33618	1	
	1/4" Nut	076-36302	1	
49	Red Heat Swrink 1/2" ID	089-669985	1 1/2"	
50	Additive Injector Holder	MT-3X1500-41	1	B
51	5/16" x 2" Bolt	076-13061	1	
	5/16" L/W	076-33620	1	
	5/16" F/W	076-3006	1	
	5/16" Nut	076-33006	1	
52	Wheel Link Chain Eye	MT-3X1500-140	2	B
53	Wheel Link Holding Chain	MT-3X1500-141	2	
54	1/4" x 2 1/2" Bolt	076-13013	2	
	1/4" Lock Nut	076-37018	2	

PAINT:
B - Black
O - Orange

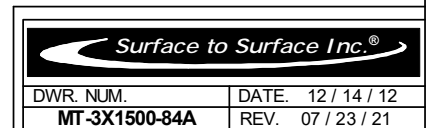

MAC JR 1200 2" PIPING ASSEMBLY PARTS LIST

REF #	DESCRIPTION	STS PART NUMBER	QTY REQ.
51	2" Male Cam-loc x Hose Barb	025-200-E-AL	2
52	Hose Clamp	025-HS-32	12
53	2" Rubber Hose	MT-3X1500-40-D	1
54	2" NPT x Hose Barb	018-1661266241	6
55	2" NPT 90° Street Elbow	018-310-01720-7	5
56	Short Jet Nozzel Manifold	MT-3X150024-B	1
57	2" Female Cam-loc x Hose Barb	025-200-C-AL	2
58	2" Rubber Hose	MT-3X1500-40-B	1
59	2" NPT 45° Elbow	018-310-02440-1	1
60	2" NPT x 6" Nipple	018-330-03895-X	1
61	2 1/2" x 2" NPT Bushing	018-318-90785-X	6
62	2 1/2" NPT 3-way Ball Valve	022-0355N-T-KIT	2
63	2" NPT Pipe	MT-3X1500-27-C	2
64	2" NPT Pipe	MT-3X1500-27-A	1
65	2" NPT 90° Elbow	018-310-00180-5	2
66			
67	2" NPT Pipe	MT-3X1500-23-B	1
68	2" NPT Pipe	MT-3X1500-23	1
69	2" Rubber Hose	MT-3X1500-40-G	1
70	Long Jet Nozzel Pipe	MT-3X1500-24-A	2
71	2" Rubber Hose	MT-3X1500-40-F	1
**72	Large Jet Nozzel 60 Hz.	086-T2MP-L	12
**72-A	Small Jet Nozzel 50 Hz.	086-T0MP-L (2MP)	4
73	2" Groove Bolt Type Clamp	020-390-00026-3	1
	2" EPDM gromlock seal (gasket)	020-390-078640	
74	2" Rubber Hose	MT-3X1500-40-A	2
75	2" Groove Bolt Type Clamp	020-390-00026-3	1
	2" EPDM gromlock seal (gasket)	020-390-078640	1
76	2" Grooved 45° Elbow	020-390-01478-6	1
77	Valve Lable Plate (Left) on M2-922	M2-738-L	1
78	Valve Lable Plate (right)	M2-738-R	2
79	1/4" x 3/4" BHCS Z	076-94051	6
	1/4" Ny-Lock Nut	076-37018	6
80	Plastic Space	084-MFW130A	1
81	Valve Handle Stop	M2-664	1
82	Valve Handle	M2-665	1
83	Additive Injector	MT-3X1500-42	1
84	Pipe Cap	018-318-90072-7	3

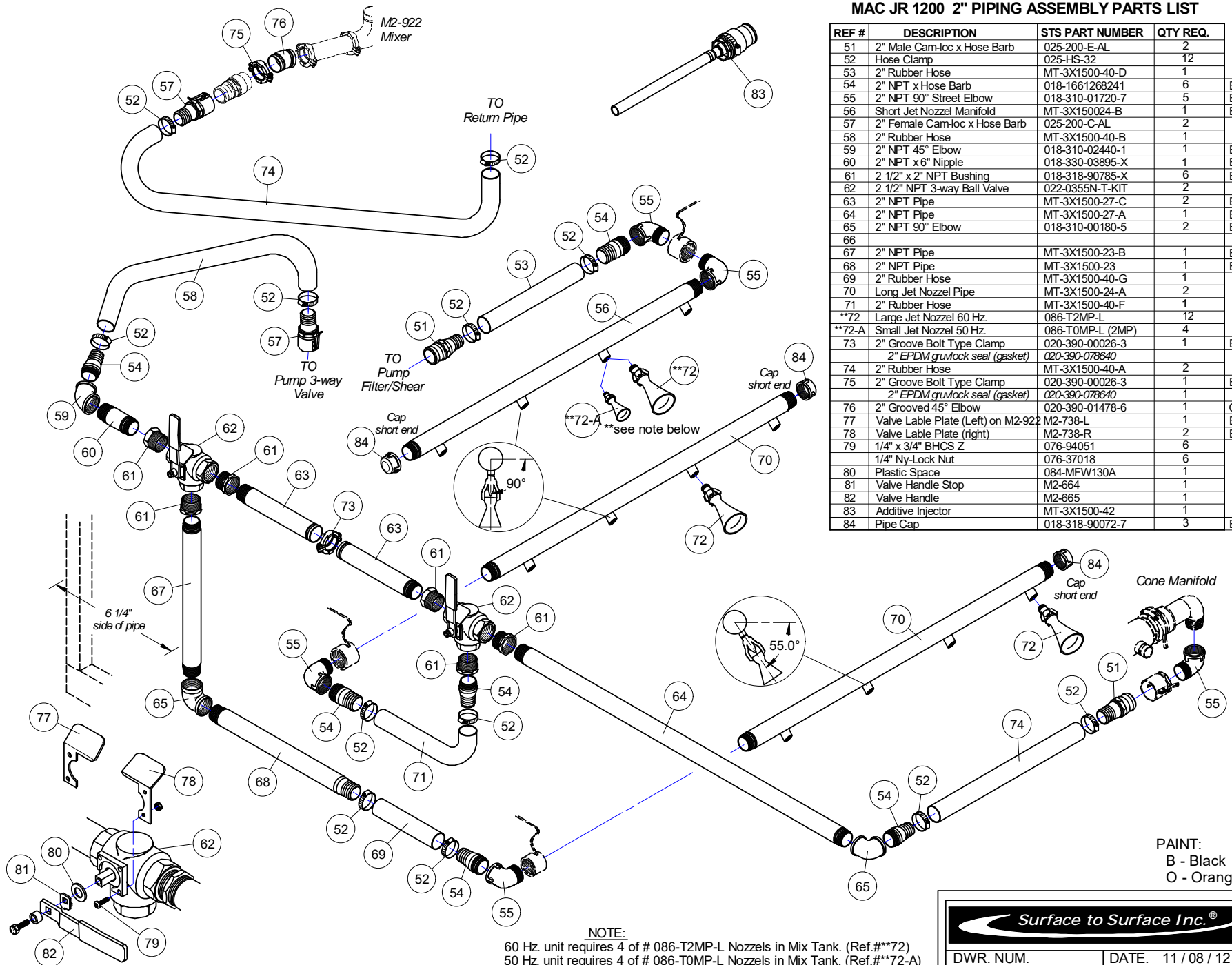

PAINT:
B - Black
O - Orange

NOTE:
60 Hz. unit requires 4 of # 086-T2MP-L Nozzels in Mix Tank. (Ref. #**72)
50 Hz. unit requires 4 of # 086-T0MP-L Nozzels in Mix Tank. (Ref. #**72-A)

Surface to Surface Inc.®

DWR. NUM.	DATE. 11 / 08 / 12
MT-3X1500-85	REV. 04 / 13 / 21

MAC JR 1200 2" SUCTION PIPING ASSEMBLY PARTS LIST

REF #	DESCRIPTION	STS PART NUMBER	QTY REQ.
90	2" Male Cam-loc x Hose Barb	025-200-E-AL	1
91	Hose Clamp	025-HS-32	2
92	2" Rubber Hose	MT-3X1500-40-D	1
93	Suction Manifold	MT-3X1500-20	1
94	2" Groove Bolt Type Clamp	020-390-00026-3	7
	2" EPDM grovlock seal (gasket)	020-390-078640	
95	2" Grooved Butterfly Valve	023-7005-011049	3
96	2" Grooved End Cap	020-390-03014-6	1

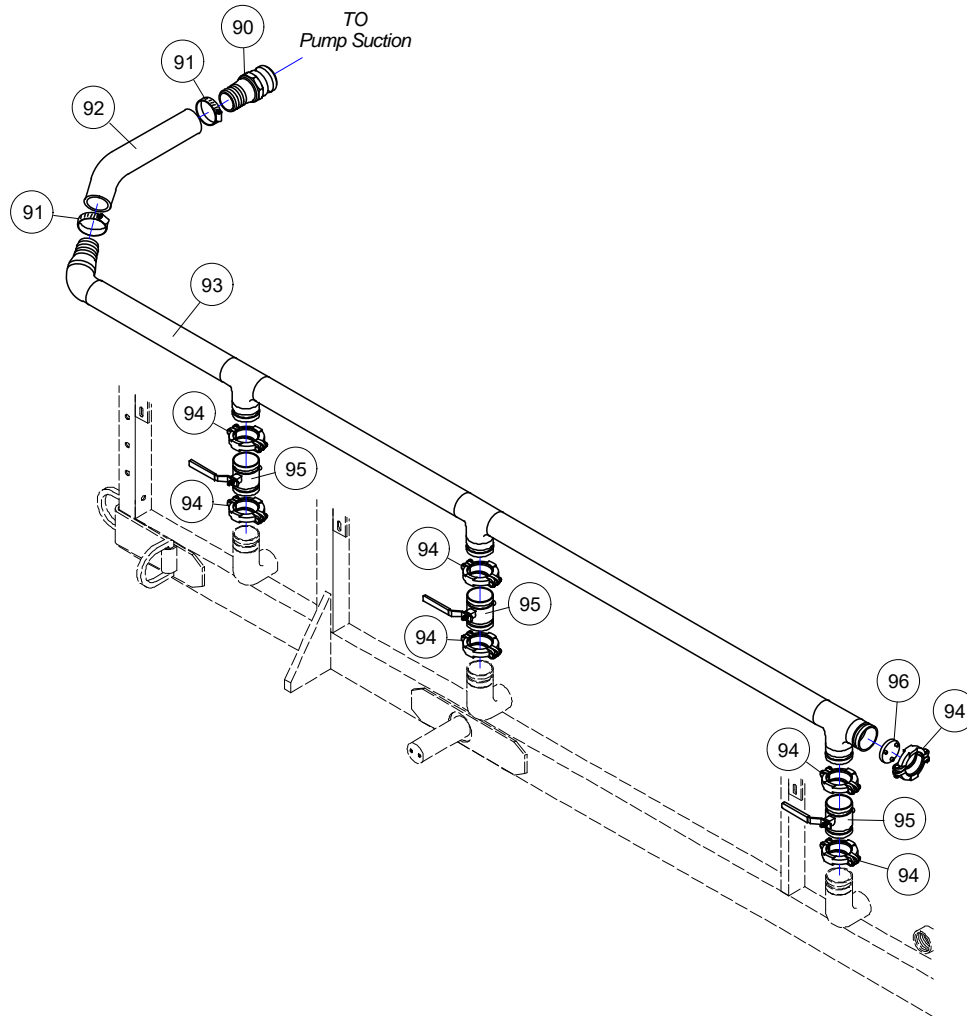

Surface to Surface Inc.®

DWR. NUM.	DATE. 11 / 22 / 12
MT-3X1500-86	REV. 01 / 30 / 13

Note: Top hole

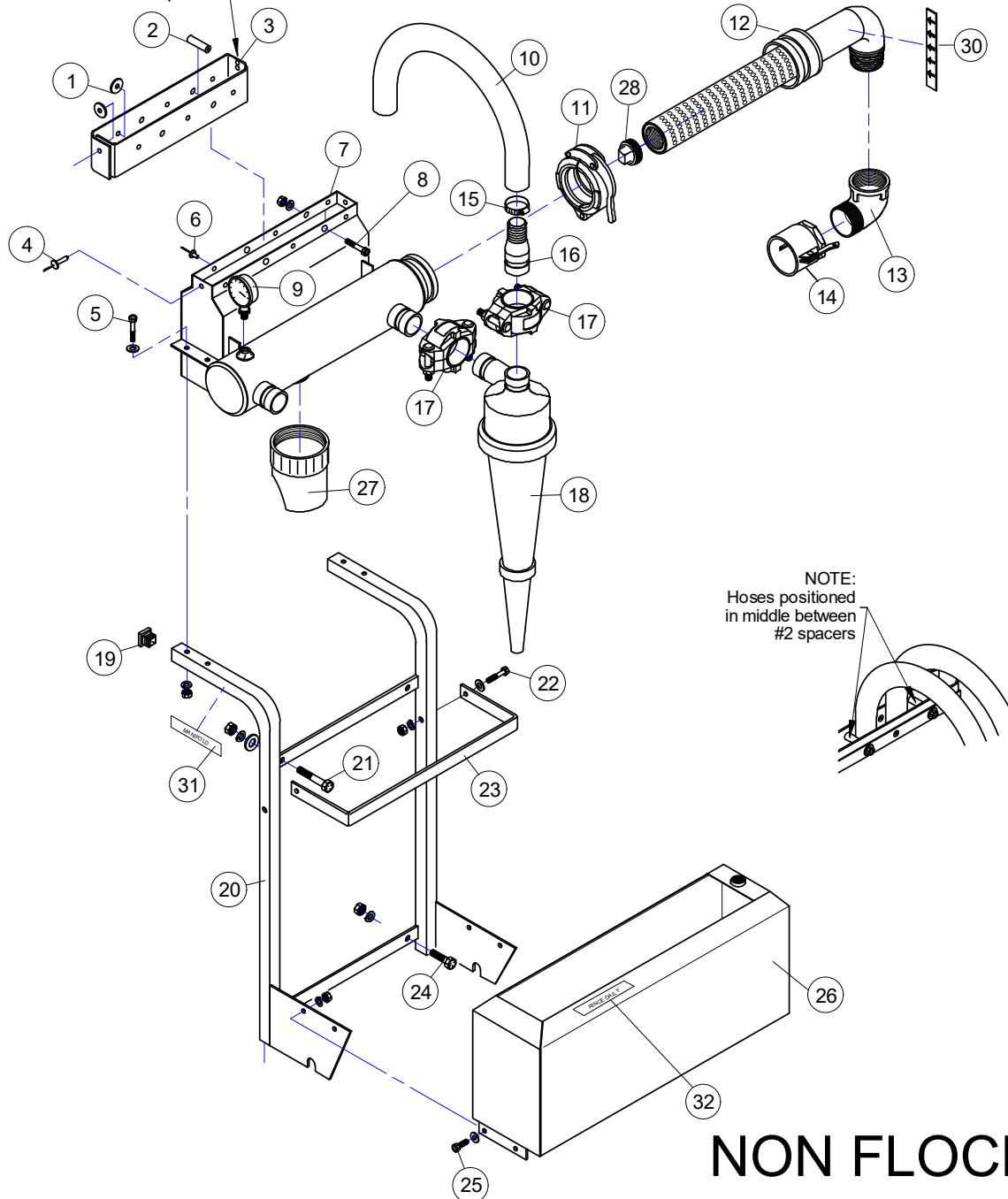

NOTE:
Hoses positioned
in middle between
#2 spacers

MAC JR 1200 CONE HEAD ASSEMBLY PARTS LIST
(P/N #MT-3X1500-87) (No Flock) (85 lbs.)

REF #	DESCRIPTION	STS PART NUMBER	QTY REQ.
1	3/16" Large back-up washer	076-1133202	8
2	Shield Spacer	076-92511A081	2
3	Over-Flo Box Rubber Shield	H360-2-014-B	1
4	Rivet 3/8" x 3/8 grip	076-41027	1
5	1/4" x 1 1/2" Bolt	076-13009	4
	1/4" F/W	076-33004	4
	1/4" L/W	076-33618	4
	1/4" Nut	076-36302	4
6	Rivet 3/8" x 1/4 grip	076-41025	7
7	Over-Flo Box & Manifold	H360-2-009	1
8	1/4" x 2 1/2" Bolt	076-13013	2
	1/4" L/W	076-33618	2
	1/4" Nut	076-36302	2
9	Pressure Gauge	035-CF-1P-60-A	1
10	Cone Hose	H360-2-014-A	2
11	3" Hinge-Loc Coupler	020-390-20006-1	1
	3" Coupler EPDM Gasket	020-390-078681	
12	Manifold Removable End	H360-2-029	1
13	2" NPT 90° Street Elbow	018-310-01720-7	1
14	2" Female Can-loc x Female NPT	025-200-D-AL	1
15	Gear Clamp	025-HS-24	2
16	1 1/4" Groove x Hose Barb	020-D19-STV15	2
17	1 1/4" Groove-Loc Coupler	020-390-00022-2	4
	1 1/4" Coupler EPDM Gasket	020-390-078620	
18	Hydro-cyclone	088-48-0821	2
19	1" Sq Plastic Plug	084-SQR101014A	2
20	Top Head Legs	H360-2-005	1
21	3/8" x 3" Bolt	076-13115	2
	3/8" F/W	076-33008	2
	3/8" L/W	076-33622	2
	3/8" Nut	076-36306	2
22	5/16" x 1 3/4" Bolt	076-13060	2
	5/16" F/W	076-33006	2
	5/16" L/W	076-33620	2
	5/16" Nut	076-36304	2
23	Cone Support Bar	H360-2-032	1
24	3/8" x 1" Bolt	076-13105	2
	3/8" L/W	076-33622	2
	3/8" Nut	076-36306	2
25	1/4" x 3/4" Bolt	076-13003	4
	1/4" F/W	076-33004	4
	1/4" L/W	076-33618	4
	1/4" Nut	076-36302	4
26	Under-flo Box	MT-3X1500-400	1
27	ABS Female NPT x Socket Adpt	MT-3X1500-218	1
28	1 1/2" NPT Pipe Plug	018-318-90252-5	1
29			
30	Directional Tape	STS-PIPE MARKER	12'
31	"Manifold" Decal	H360-2-091	1
32	"Rince Daily" Decal	H360-6-055	1
33			
34			
35			
36			

Paint Colors
Black = B
Orange = O

NON FLOCK

Surface to Surface Inc.®

DWR. NUM.	DATE.
MT-3X1500-87	12 / 05 / 12
	REV. 03 / 19 / 21

OPTIONAL

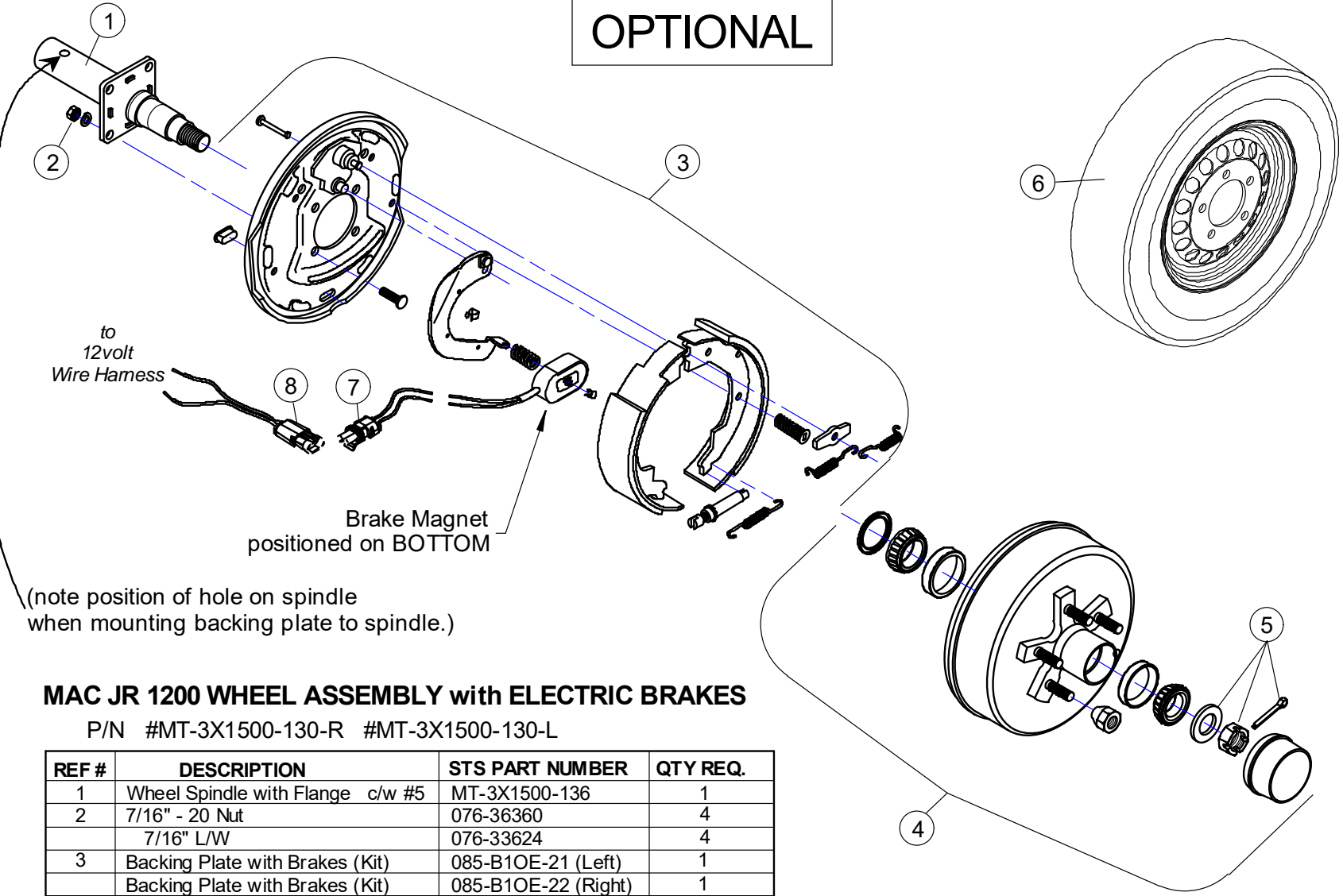

to
12volt
Wire Harness

Brake Magnet
positioned on BOTTOM

(note position of hole on spindle
when mounting backing plate to spindle.)

MAC JR 1200 WHEEL ASSEMBLY with ELECTRIC BRAKES

P/N #MT-3X1500-130-R #MT-3X1500-130-L

REF #	DESCRIPTION	STS PART NUMBER	QTY REQ.
1	Wheel Spindle with Flange c/w #5	MT-3X1500-136	1
2	7/16" - 20 Nut	076-36360	4
	7/16" L/W	076-33624	4
3	Backing Plate with Brakes (Kit)	085-B10E-21 (Left)	1
	Backing Plate with Brakes (Kit)	085-B10E-22 (Right)	1
4	Brake Drum Assembly less #5	085-27-290-BC-1	1
5	1" - 14 Castle Nut	~~~	1
	1" SAE Flat Washer	~~~	1
	Cotter Pin	~~~	1
6	Tire & Rim	MT-3X1500-139	1
7	2 Prong Male Plug w/pig tail	089-5681-11	1
8	2 Prong Female Plug w/pig-tail	089-5686-11	1

LEFT Assembly Shown (p/n #MT-3x1500-130-L)

NOTE: The Only difference between the right side (#MT-3X1500-130-R) and left side (#MT-3X1500-130-L) kits is item #3

Surface to Surface Inc.®

DWR. NUM.	DATE. 08 / 13 / 18
MT-3X1500-130	REV. 08 / 20 / 20

MAC JR 1200 CONE HEAD LIFT ASSEMBLY PARTS LIST

REF #	DESCRIPTION	STS PART NUMBER	QTY REQ.	
1	Left Side Slider	#MT-3X1500-95-L	1	B
2	Right Side Slider	#MT-3X1500-95-R	1	B
3	Push Mount	#MT-3X1500-95-A	1	B
4	Slide Rail	#MT-3X1500-91	1	B
5	3/8" x 1 1/4" FHSCS	076-24287	6	
	3/8" L/W	076-33622	6	
	3/8" Nut	076-36306	6	
6	3/8" x 3" FHSCS	076-24294	2	
	3/8" L/W	076-33622	2	
	3/8" Nut	076-36306	2	
7	Lift Jack Head	#MT-3X1500-97-H	1	B
8	Lift Jack Post	#MT-3X1500-97-P	1	
9	3/8" x 2" Bolt	076-13111	2	
	3/8" L/W	076-33622	2	
	3/8" Nut	076-36306	2	
10	3" NPT Elbow	018-310-00220-9	1	B
11	2" Rubber Hose	MT-3X1500-99-A	1	
12	Top Head Legs	H360-2-005	1	
13	Tank Frame	#MT-3X 1500-03	1	

PAINT:
B - Black

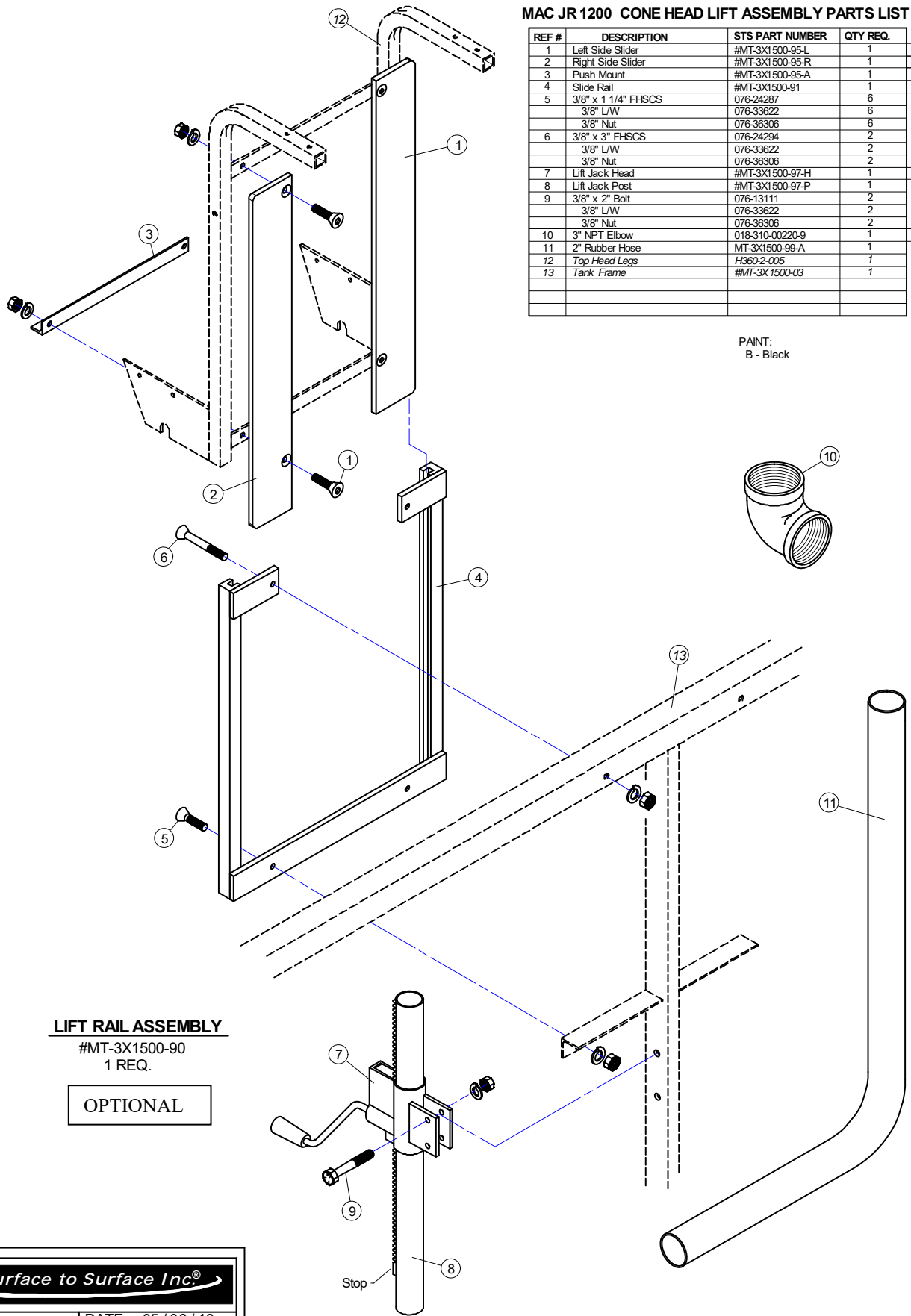

LIFT RAIL ASSEMBLY

#MT-3X1500-90
1 REQ.

OPTIONAL



DWR. NUM.	DATE. 05 / 06 / 13
MT-3X1500-90	REV.

