



# Bentonite Mud Mixer Model M-750H

## Surface to Surface Inc.



### Features and Benefits M-750H Mixer

The M-750H with its rectangular loaf shaped Roto-Mold tank, is a space saving design with almost square footprint dimensions. Powered by the customer's own power source, a 16 1/2gpm hydraulic motor drives a 4 inch centrifugal pump making effective use of the proprietary StS mixing system, this Bentonite Mud Mixer is capable of providing 750 gallons of full yield mud to your drill rig in less than eight (8) minutes. Added benefits to this unit include the ability to draw water from a second tank and send mud to your drilling rig or storage tank with-out the use of a second pump. Other power drives available.

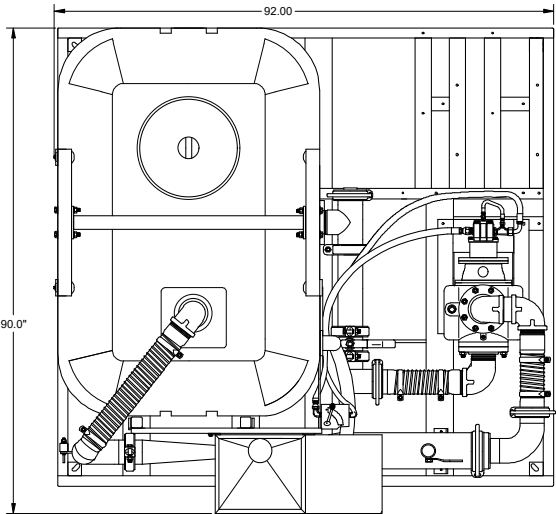

### Specifications

- Dimensions
- Approx. Weight
- Hopper Height
- Mixing System
- Mixing Tank
- Skid frame
- Hydraulic Motor
- Hydraulic Valve
- Hydraulic system
- Pump
- Pump Drive
- Mechanical Seal
- Replaceable Wear Plate
- Pipe Couplers
- Pressure Wand
- Tank Drain

### M-750H Mixer

- 92"W x 90"L x 75"H
- 1800 lbs.
- 39 inches high
- 4" Proprietary StS Mixing System
- 750 gallon Roto-Mold Polyethylene
- 5" Steel Channel, Welded
- Requires 15-16½ us.gpm. @ 2000psi
- Variable speed control
- Open loop circuit
- 4" Cast Iron Centrifugal Trash Pump
- Hyd. Motor direct to Bearing Block
- Self Pressurizing Grease Seal
- Hardened plate ahead of Impeller
- Bolt and Snap –Groove Type
- Hopper Maintenance Wand
- Bottom Tank Drain Supplied

### Benefits

- Fits any 8' flat deck and makes efficient use of available space.
- Waist high hopper reduces back strain.
- Fast, efficient mixing time ( 8 min. mix ).
- Minimal maintenance required.
- Built for the rigors of the construction trade.
- Air Cooled, Industrial rated for long service life.
- Allow bentonite mixing at various speeds
- Simple, field repairable, less maintenance
- Rugged & Repairable for extended service life.
- No expensive couplers or inserts to replace.
- Greaseable seal for more rugged working conditions
- Less wear on internal pump parts and is replaceable.
- Provide fast cold weather maintenance.
- Removal of any build-up caused by additives.
- Provides fast cold weather tank drainage.

**Also available in Diesel (M-750D) - Gasoline (M-750G) – Electric (M-750E) models.**

\* All Specifications Subject to Change Without Notice \*\*\*

Check our website for the latest products and specifications  
**www.stsmixers.com**

## Surface to Surface Inc.

5150 Forest Road, R.R.#3, Watford, Ontario, N0M 2S0  
Tel: 1-800-567-0978

09/20/12