

Operators Manual

**** M-500G ****

USE IN CONJUNCTION WITH OEM MANUALS (ENCLOSED)

Unit Serial No. _____

Briggs & Stratton Engine

Vanguard – Serial No. _____

Gorman-Rupp Pump

GR-83A2 – Serial No. _____

Links relating to this Manual

www.stsmixers.com
www.briggsandstratton.com
www.grpumps.com

Dealer

TABLE OF CONTENTS

	PAGE
STS Inc Warranty	5
Safety Statements	6-9
Safety Markings	10
Main Working Components (Photo)	11
Introduction to the M-500G	12
M-500G Foot Print (top view)	13
M-500G General Data Sheet	14
Identifying Your Machine & Components	15
<u>SECTION II</u> (Description, Care and Maintenance)	
Polyethylene Plastic Reservoir Tank.....	17-18
Gasoline powered centrifugal pump.....	19-22
Filter shear system.....	23-24
Venturi mixing tee.....	25
Wash wand.....	26
Dry hopper with table & hopper valve.....	27
Internal tank jet gun.....	28
<u>SECTION III</u> (Set-up and installation of unit in Detail)	
Permanent mounting of unit.....	30
Portable use of unit.....	30

TABLE OF CONTENTS

	PAGE
<u>SECTION IV</u> (<i>Operating the M-500G Unit.</i>)	
Site set-up and pre-check.....	32
Starting the engine and Pump.....	33
Typical mixing operation.....	34
Typical transfer / off-loading operation.....	35
Shutdown, cleanup & storage	
Warm weather.....	36
Cold/ freezing weather.....	37
Prolonged periods of storage.....	38
**Optional self-loading feature.....	39
<u>SECTION V</u> (<i>Trouble shooting</i>)	
Trouble Shooting the M-500G.....	41-42
<u>SECTION VI</u> (<i>Periodic Maintenance & Repair Information</i>)	
Maintenance Schedule.....	44
Centrifugal Trash Pump Seal Replacement.....	45
Bolt torque Specifications.....	46
Notes.....	47

TABLE OF CONTENTS

	PAGE
<u>SECTION VII</u> (<i>OEM Repair Information</i>)	
GR Centrifugal Pump Owner's Manual.....	49-60
Engine Manufacture Customer Help (web-site).....	61
Gruvloc® Pipe Couplings.....	62-64
<u>SECTION VIII</u> (<i>Parts Manual</i>)	
M-500G PARTS MANUAL.....	66-69



Limited Warranty

United States and Canada

Surface to Surface Inc. or its subsidiary which last sold the product, warrants new products sold by it for use in the United States and Canada to be, at the time of manufacture, free from defects in workmanship and materials. This warranty covers for a period of **Twelve (12) Months** of operation from the date of delivery for initial use, whichever comes first.

Exclusions and Additional Limitations

1. This warranty relates to the condition of the product at the time of manufacture and does not cover parts or service as a result of:
 - (a) Normal wear and tear or required maintenance including, without limitation, adjustments or replacement of components subject to wear and tear, such as belts, hoses, seals and/or packing, fuses, bulbs, switches and ignition parts.
 - (b) Abuse including, without limitation, neglect, improper operation, misapplication, overloading, accident or alterations not approved by Surface to Surface Inc.
 - (c) Lack of maintenance, including, without limitation, failure to inspect and maintain, improper repair, use of "unapproved parts", cracked engine heads and blocks unless caused by the failure of an internally lubricated part or repair of engine valves, rings or guides.
2. The Company's warranty does not apply to purchased components manufactured by others where separate warranty is made by the manufacture of such components and will be applied as interpreted by the supplier.
3. All claims under his warranty shall be submitted in writing by the distributor to the Company, which will be the sole judge in determining the merits of the claim.
4. The company shall have the right to have all products or parts claimed to be defective returned to it and the cost of shipping such items shall be borne by the distributor.

.....

Warranty Registration Card

In order to help us provide complete service for our product, please complete this card and return it.

If not returned, all requests for warranty will be denied.

Print Name:

Address:

City:State/Province.....Zip/PC.....

Model No. Serial No.

Date of Purchase Dealer

**Return to: Surface to Surface Inc.
5150 Forest Rd. RR#3
Watford, Ontario, Canada
N0M 2S0**

SAFETY STATEMENTS

Your personal safety and the safe operation of this unit are the concern of Surface to Surface Inc, and by reading and understanding this manual and understanding the safety statements, you will decrease the risk of personal and equipment damage.

Safety statements are listed here and throughout this manual to draw your attention to potential hazards that may be encountered while operating this piece of equipment. While reading this manual, you will notice that certain safety statements will relate directly to the operation, or maintenance of that particular part of the unit and should be followed carefully. Decals on the unit also follow the same format as the warnings in this manual, and therefore should be kept in good repair to alert the operator and others of the potential hazard.

The engine / motor manual also contains hazard warnings which pertain to the engine / motor and should also be followed.

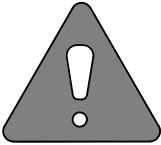

*This safety alert symbol appears with most safety statements.
It means attention, become alert, your safety is involved!
Please read and abide by the message that follows the safety alert symbol.*

 DANGER
<p>Danger (the word "DANGER" is in white letters with a red rectangle behind it) indicates an imminently hazardous situation, which, if not avoided, will result in death or serious injury. Danger is limited to the most extreme situations.</p>

 CAUTION
<p>Caution (the word "CAUTION" is in black letters with a yellow rectangle behind it) indicates an potentially hazardous situation which, if not avoided, may result in minor or moderate injury.</p>

 WARNING
<p>Warning (the word "WARNING" is in black letters with an orange rectangle behind it) indicates an potentially hazardous situation which, if not avoided, could result in death or serious injury.</p>

CAUTION
<p>Caution "without the safety alert symbol" indicates an potentially hazardous situation that can cause damage to the, machine, personal property and / or the environment or cause the machine to operate improperly.</p>

SAFETY STATEMENTS

The following caution statements have been drawn from the instructions in this manual. They have been assembled here for ready reference.

 DANGER

IN AN EMERGENCY
rotate the engine speed control lever
to the **STOP** position
to halt engine, pump, and fluid flow

 WARNING

**NEVER ATTEMPT TO REMOVE
OR CLEAN THE FILTER SHEAR**
while the unit is in operation.
Serious personal injury will result.

 DANGER

**NEVER ATTEMPT REPAIRS
OR DISASSEMBLY**
without shutting off the engine / motor
and disconnecting the power source.
Serious personal injury will result.

 CAUTION

**DO NOT POSITION
ANY PART OF YOUR BODY**
over the hopper, valve,
or mixing tee while cleaning.

 WARNING

**NEVER USE BODY PARTS,
OR FOREIGN OBJECTS**
in an attempt to unplug or clean the
hopper valve or mixing tee.
Serious personal injury or
damage will result.

 CAUTION

**WHEN THE UNIT
IS IN OPERATION,**
the fluid in the piping may reach
pressures up to 50 p.s.i.
When the engine is idling, the system is
still pumping fluid under pressure.

 WARNING

**DO NOT REMOVE OR MODIFY
SAFETY COVERS OR GUARDS.**
Serious personal injury will result.

 CAUTION

**NEVER OPERATE THE MIXING
unit with the tank lid open.**
If viewing is necessary, open
only the small inspection
vent cap in the center of the lid.



M-500G

SAFETY STATEMENTS *continued*

The following caution statements have been drawn from the instructions in this manual. They have been assembled here for ready reference.

CAUTION
TRAPPED FLUID MAY BE PRESENT and will spill out when piping, hoses, pump or filter shear are removed.

CAUTION
WHEN TRANSFERRING FLUID to the drill rig, fluid pressure may reach or exceed 50 p.s.i. CHECK the drill rig manufacturers specifications regarding maximum inlet pressures allowed for their pump.

CAUTION
NEVER LEAVE LIQUID IN THE PUMP CASING, PIPING, OR HOSES during freezing weather conditions, as damage will result. Follow instruction for winterizing.

CAUTION
IMPROPER INSTALLATION OF THE MECHANICAL or GREASE SEAL will result in leakage and possible damage to the seal. All maintenance, operating and repair of this unit, must be done per the instructions in the operators manual for safety and reliability.

CAUTION
AVOID ALLOWING FOREIGN MATERIAL into the Venturi Mixing Tee thru the Hopper, by keeping the valve closed when not in use.

CAUTION
CARE MUST BE TAKEN WHEN INSTALLING THE COUPLER GASKETS. If the gaskets are not properly lubricated and installed, a leak may develop.

CAUTION
BEFORE STARTING THE ENGINE, BE SURE THE PUMP IS PRIMED! Check the pump by slowly & carefully opening the plug located on the top of the centrifugal pump discharge elbow. A visual inspection can be made if the fluid escapes around the plug as it is loosened. Remove the plug to view inside fluid level. The centrifugal pump seal WILL be damaged if allowed to cavitate or run dry.

CAUTION
BEFORE STARTING OR RESTARTING the engine and centrifugal pump, make sure any valves installed on the pump suction inlet line are open, and the fluid level in the tank is above the suction line.

SAFETY STATEMENTS *continued*

The following caution statements have been drawn from the instructions in this manual. They have been assembled here for ready reference.

CAUTION

LIFTING LUGS OR THE LIFTING POINT(S) identified and labelled on the skid structure must be used in order to safely lift and transport the unit.

CAUTION

BEFORE LIFTING OR MOVING THE UNIT, all fluid should be removed from the tank.

CAUTION

The manufacturer should be consulted when considering alternative uses for this piece of equipment. This unit was designed for the mixing and shearing of a dry additive, into a liquid stream. Other uses may create unforeseen safety issues and personal injury risk.

CAUTION

AVOID PLACING OBJECTS on top or against the tank as damage may result from the weight.

CAUTION

TO ENTER THE TANK is not recommended. Personal injury could result from the presents of hazardous fumes, remaining fluid or unit start-up.

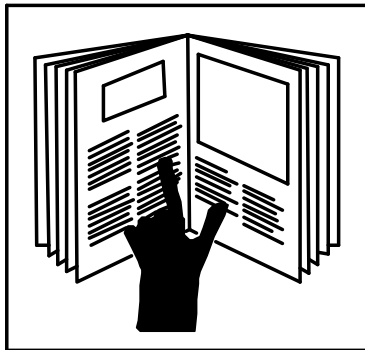

WARNING

REFER TO THE SAFETY STATEMENTS IN THE ENGINE OEM MANUAL AND THIS MANUAL REGARDING THESE OPERATIONS.

M-500G

Safety Markings

Hazard and warning markings have been placed at appropriate points on the unit. International symbols have been used, in order to ensure universal understanding of the nature of the hazard. Please comply with all warnings and markings to ensure safe use of the equipment. These include but are not limited to:

- a) Lifting points
- b) Flammable Liquids
- c) High temperature areas
- d) Personal Protection recommendations
- e) Personal dangers
- f) Equipment dangers
- g) Operating instructions
- h) Fluid flow direction

SOME EXAMPLES FOUND ON THE EQUIPMENT



Personal Protection, Read and understand Operator's manual and Maintenance manual



Lifting Point



Flammable Liquid



Hot Surface



No Step



Fluid Flow Direction

CLEAN FILTER DAILY

Maintenance Instructions

KEEP LID CLOSED
WHILE MIXING

Safety Instructions

M-500

Main Working Components

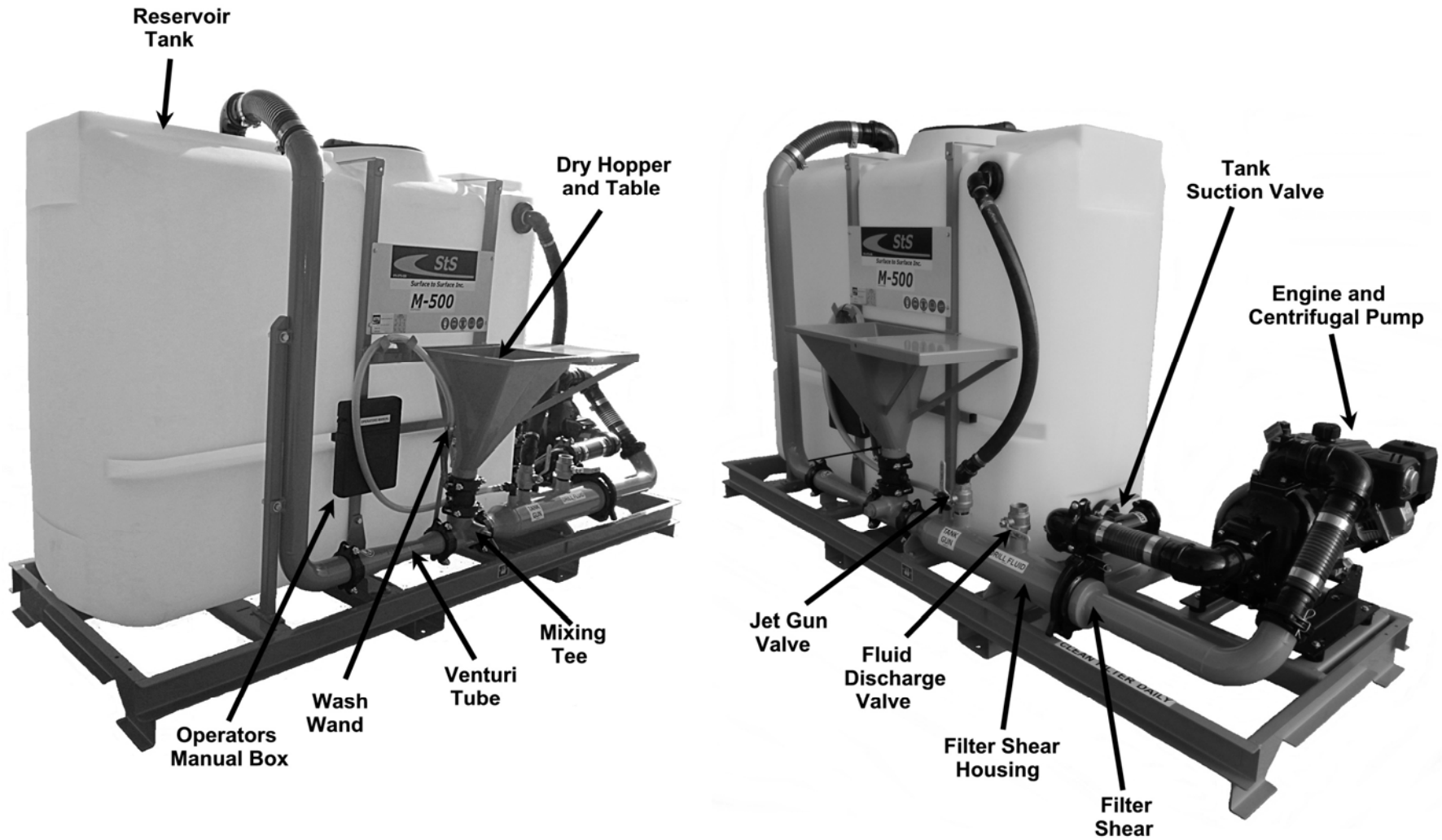



M-500G
Operators Manual

Congratulations on your acquisition of the world renowned M-500 Mixing System. You have acquired the fastest and most efficient mixing system manufactured for mixing Bentonite drilling slurry (mud). As a manufacturer of HDD support equipment, we are well aware of the extreme conditions that HDD equipment is exposed to on a daily basis. Surface To Surface Inc. strives to overcome these conditions, with better design and manufacturing practices. Please feel free to call our toll free number (1-800-567-0978) if you have any questions or concerns about your M-500.

Thank you, for choosing the M-500

The M-500G mixing unit was designed to mix dry or liquid drilling products with clean water, into a slurry. The slurry is continually circulated through the mixing cycle until it reaches the desired consistency. The operator can then transfer the final product to a holding reservoir or directly to the drilling equipment.

The M-500 mixing unit consists of a 500 u.s. gal. (1893 litre) polyethylene plastic tank, gasoline powered centrifugal pump, filter/shear unit, venturi mixing tee assembly, dry hopper with a table, tank internal jet gun and a discharge valve to pump the finished slurry to a holding tank or the drill rig. These components are all mounted on a frame type skid, built for lifting or solid mounting. For ease of interpretation, looking at the mixing unit hopper straight on will be considered looking at the front of the unit. Hence the other long side, will be the rear and the ends will be right or left end.

RECORD OF OWNERSHIP:

- Unit Serial No. _____
- Engine Serial No. _____
- Pump Serial No: _____
- Tank Serial No: _____
- Date Purchased/Leased: _____
- Dealer Purchased/Leased From: _____
- Special Custom Features: _____

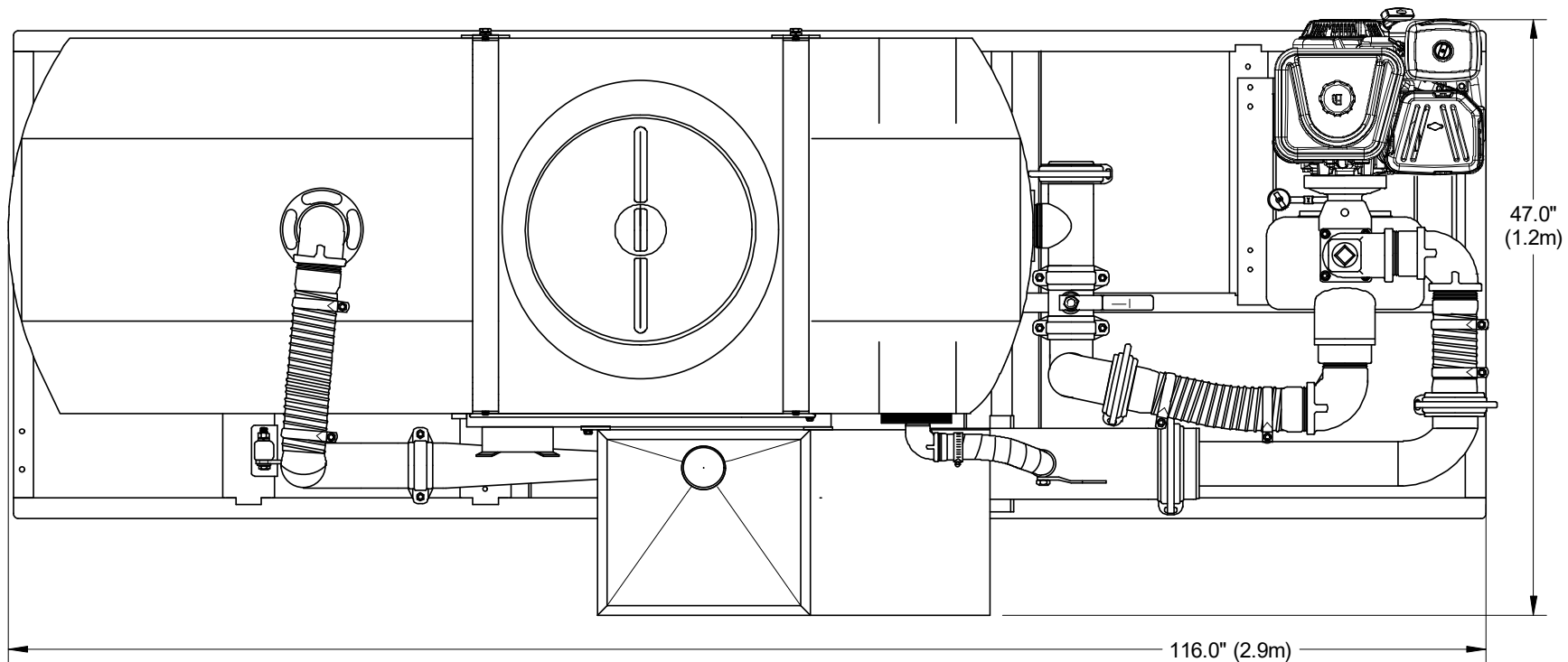

M-500G (Gasoline)

DRY WEIGHT
 1020 lbs. (463 Kg.)
 Height: 69 1/2" (1.7m)

** Due to our continuing product improvement, specifications are subject to change without notice. **

	
DWR. NUM. M-500G	DATE. 10 / 23 / 23 REV.



Bentonite Mud Mixer Model M-500

Surface to Surface Inc.



Features and Benefits M-500 Mixer

The M-500 is designed and manufactured primarily for the HDD mini size drill rigs and tunnelers, as an alternative to using plain water. Powered by a 10 hp air-cooled gasoline engine, driving a 3" centrifugal pump that makes effective use of the proprietary 4 point mixing system, making it fast and powerful. This Bentonite mud mixer is capable of providing 500 gallons of full yield mud to your drill rig in less time than the competition. This compact unit can be mounted in a truck or on a trailer and transported to the job site with ease.

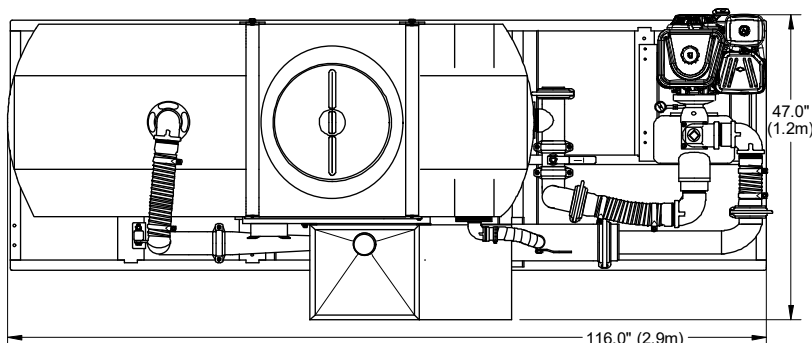

Specifications

Dimensions
Weight
Hopper Height
Mixing System
Mixing Tank
Skid Frame
Engine
Pump
Pump Coupling
Drill Fluid Outlet
Pipe Couplers
Pressure Wand
Tank Drain

M-500Mixer

47" W x 116" L x 70" H
1020 Lbs.
37" High
3" Proprietary StS Mixing System
500us gal Polyethylene
Formed steel, welded
10 hp air-cooled, manual start
3" Cast iron centrifugal trash pump
Direct coupled engine & pump
1 1/2" NPT with Full Flow Ball Valve
Bolt & Snap-groove type
Hopper maintenance wand
Bottom tank drain supplied

Benefits

Small space saving footprint.
Light weight for easy transportation.
Waist high hopper reduces back strain.
Fast & efficient .
Minimal maintenance required.
Built tough for the construction trade.
Industrial rated for longer service life.
Rugged & repairable for extended service life.
No expensive couplers or inserts to replace.
Large volume discharge
Fast cold weather draining of system.
Removal of blockages caused by additive.
Fast cold weather draining.Customer Installed

Also available in Electric (M-500E) Hydraulic (M-500H) Diesel (M-500D) models.

*** All Specifications Subject to Change Without Notice ***

Check our website for the latest products and specifications
www.stsmixers.com

Surface to Surface Inc.

5150 Forest Road, R.R.#3, Watford, Ontario, N0M 2S0
Tel: 1-800-567-0978

11/03/23



M-500G

Identifying Your Machine & Components

Location of Tags and PIN Plates

Unit
Serial Number

Operators
Manual

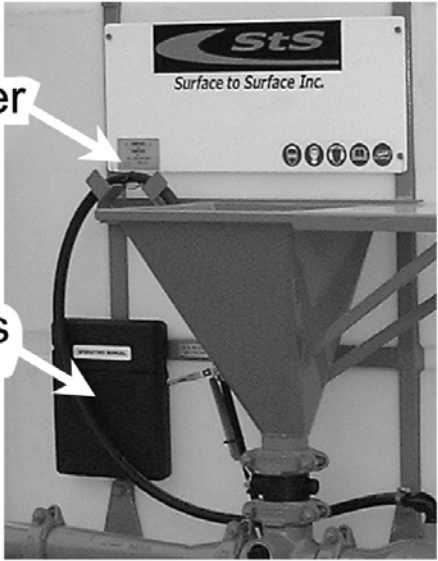

Pump
Serial Number

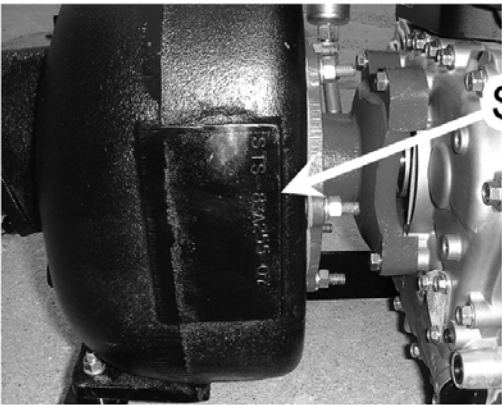

Engine
Serial Number

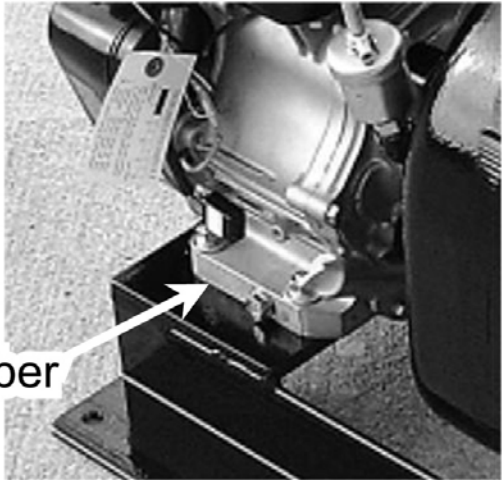

SECTION #II

Description, Care and Maintenance

M-500G

Description, Care and Maintenance

Polyethylene Plastic Reservoir Tank (500 us. gal)

Maintenance of this tank is required, but is simple. The tank should be cleaned on a regular basis by opening the drain cap on the tank tee, located at the bottom right end of the tank (see Fig.1) and rinse the tank with clear water. Residue such as leaves, stones, etc and remaining water can be removed using a wet /dry vacuum.

All tank ports are of a threaded type bung (see Fig.1) with rubber gaskets. If a leak is noticed between the tank and gasket, the connection can be tightened up by tightening the large nut flange in the direction of the arrows (counter clock wise).

Fig.1



⚠ DANGER
NEVER ATTEMPT REPAIRS OR DISASSEMBLY
 without shutting off the engine / motor and disconnecting the power source. Serious personal injury will result.

⚠ CAUTION
NEVER OPERATE THE MIXING unit with the tank lid open.
 If viewing is necessary, open only the small inspection vent cap in the center of the lid.

CAUTION
BEFORE LIFTING OR MOVING THE UNIT,
 all fluid should be removed from the tank.

CAUTION
TO ENTER THE TANK is not recommended
 Personal injury could result from the presents of hazardous fumes, remaining fluid or unit start-up.

M-500G

Description, Care and Maintenance

Polyethylene Plastic Reservoir Tank (500 us. gal)

INSTALLATION OF Optional (CUSTOMER INSTALLED) TANK DRAIN

- Find a suitable location on the tank floor for the drain to be installed, taking into consideration the placement of the unit on a trailer. **LOOK** under the deck for obstructions (cross-members, wiring, and axles, ect.) Allow room for a shut off valve.
- Drill holes into floor of tank using the top (inside) portion of the drain as the template.
- Make sure the holes are free of burrs and both surfaces are clean.
- Install the drain bung as per FIG 1. Note the gaskets are on the inside and outside of the tank.
- Tighten nuts as to slightly squeeze the rubber gaskets.
- Cut a hole into the deck of the trailer or truck for the piping and valve to be installed.
- Install 2” pipe nipple and valve into tank bung with a sealant on the threads. **CAUTION: DO NOT OVER-TIGHTEN!**
- The nipple and valve should not extend to far from the tank without a support, as this will cause excess stress on the threads, drain bung and the tank floor.
- Fill with water and check for leaks.

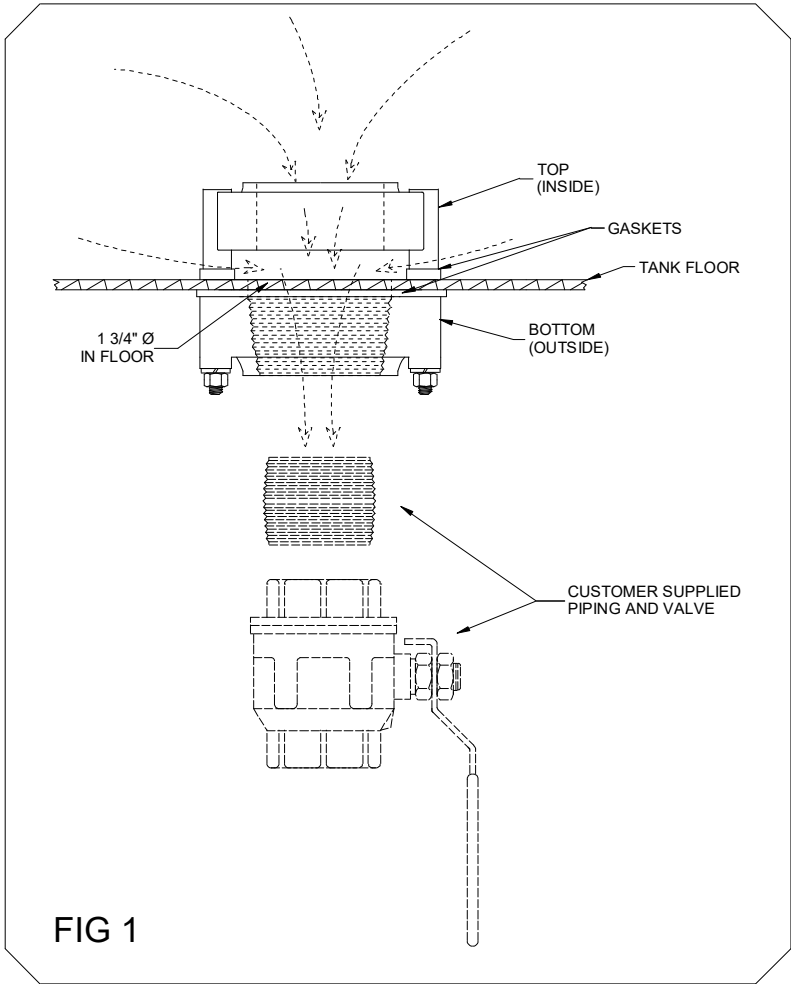
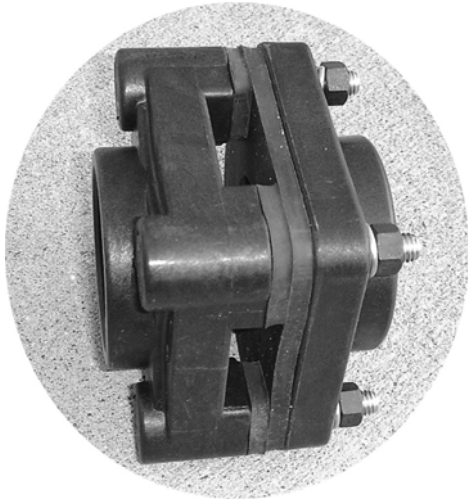

Fig.2



M-500G

Description, Care and Maintenance

Gasoline Powered Centrifugal Pump

Care and maintenance of the engine and pump are covered in this manual and/or the manufacturer operator’s manuals supplied and should be read and understood. We suggest the following daily checks be carried out prior to using the system. Check the fuel tank is full. Check oil level by removing the oil plug / dip stick, and viewing the oil level. Check the pump seal grease cup is full (see grease cup instructions Fig.5). Check the engine air filter (due to environmental conditions). Check that the suction valve (see Fig.3) is open and the reservoir tank has sufficient liquid to supply the centrifugal pump.

The pump is mounted directly to the engine, so there is no “drive coupler” to check or maintain. The pump is the primary component that will see the most wear due to the nature of the material it is handling therefore it will require regular checks, adjustments and maintenance.

There is a section of this manual dedicated to the pump itself and should be read and understood which will help should any problems or concerns arise in the field.

The pump should never be allowed to start or run dry, as this WILL damage the internal pump seal (grease seal) and render the unit inoperable until the seal is fixed.

To prime the pump or check to visually see if the pump is primed, slowly undo the plug on top of the pump discharge elbow (see Fig.4) and stop after about 3 turns. If the pump is primed, fluid & air will escape from around the plug threads. This indicates that the pump housing is full, and the plug can be tightened back up. If no fluid is escaping from around the threads, completely remove the plug & carefully remove the plug. Fluid or water can be poured into this opening to fill the pump cavity, and a visual of the fluid level inside the pump can be made. The level should be approximately to the top of the pump housing.

Another way to prime the pump is to have the tank FULL of fluid, and standing off to the side of the hopper, rotate the hopper valve SLOWLY to the open position. As the valve is opened, you will hear air escaping followed by fluid, into the hopper itself. Close the valve as the fluid enters the hopper. This means the fluid in the tank has filled the pump cavity of the pump and flowed from the outlet of the pump to the remaining piping on the unit.

Fig.3

⚠ DANGER

IN AN EMERGENCY
rotate the engine switch to the STOP position to halt engine, pump, and fluid flow

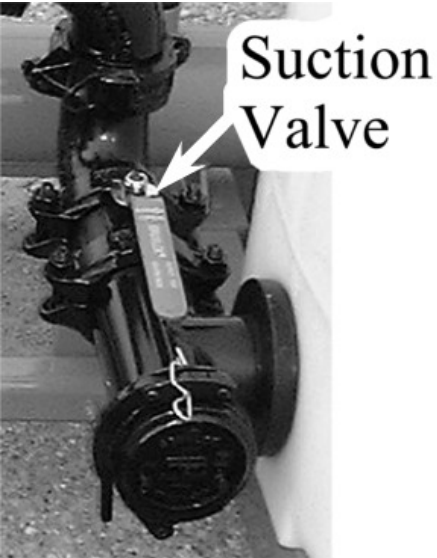

CAUTION

BEFORE STARTING THE ENGINE, BE SURE THE PUMP IS PRIMED!
Check the pump by slowly & carefully opening the plug located on the top of the centrifugal pump discharge elbow. A visual inspection can be made if the fluid escapes around the plug as it is loosened. Remove the plug to view inside fluid level. The centrifugal pump seal **WILL** be damaged if allowed to cavitate or run dry.

⚠ DANGER

NEVER ATTEMPT REPAIRS OR DISASSEMBLY
without shutting off the engine / motor and disconnecting the power source. Serious personal injury will result.

CAUTION

IMPROPER INSTALLATION OF THE MECHANICAL or GREASE SEAL will result in leakage and possible damage to the seal. All maintenance, operating and repair of this unit, must be done per the instructions in the operators manual for safety and reliability.

M-500G

Description, Care and Maintenance

Gasoline Powered Centrifugal Pump

Fig.4

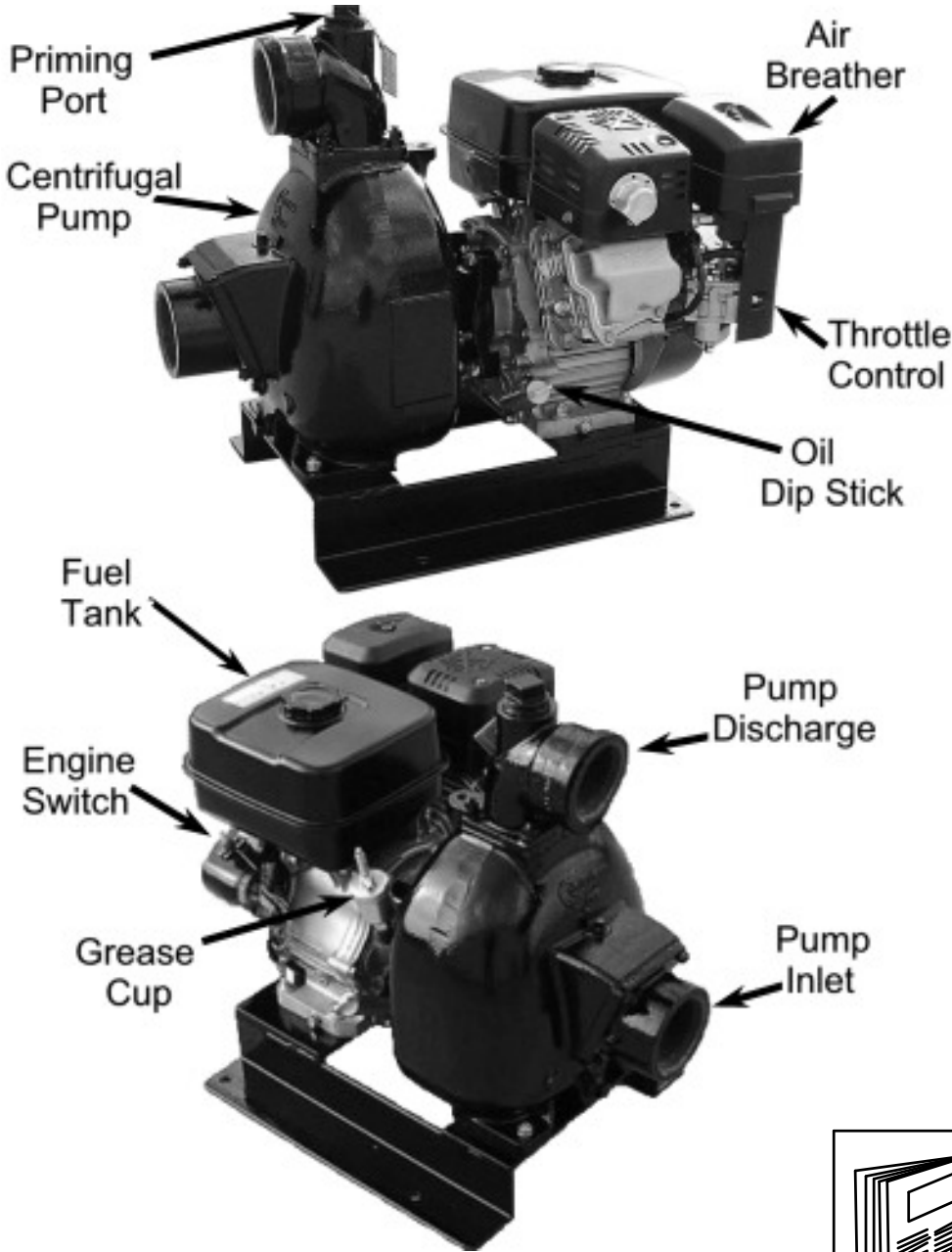

CAUTION

TRAPPED FLUID MAY BE PRESENT and will spill out when piping, hoses, pump or filter shear are removed.

CAUTION

NEVER LEAVE LIQUID IN THE PUMP CASING, PIPING, OR HOSES during freezing weather conditions, as damage will result. Follow instruction for winterizing.

CAUTION

BEFORE STARTING OR RESTARTING the engine and centrifugal pump, make sure any valves installed on the pump suction inlet line are open, and the fluid level in the tank is above the suction line.

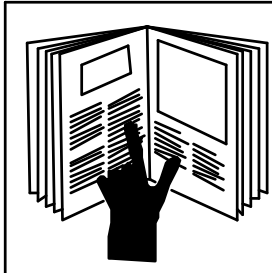

WARNING

REFER TO THE SAFETY STATEMENTS IN THE OEM SUPPLIED MANUALS AND THIS MANUAL REGARDING THESE OPERATIONS.

Description, Care and Maintenance

Gasoline Powered Centrifugal Pump

Grease cup instructions (Fig.5)

Fill the grease cup through the grease fitting with No. 2 lithium base grease until grease escapes from the relief hole. Turn the grease cup arm counterclockwise until it is at the top of the stem; this will release the spring to apply grease to the seal.

NOTE:

Some smoking and leakage may occur after installing a new seal assembly. This should stop after the pump has run a while and the lapped seal faces have seated in.

Fig.5

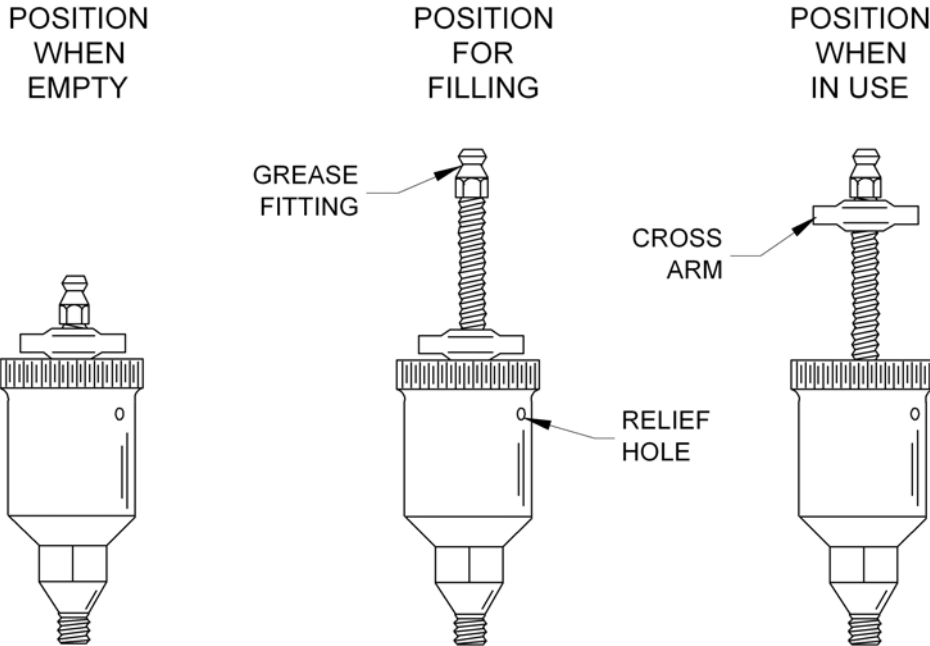

Figure 4. Automatic Lubricating Grease Cup

M-500G

Description, Care and Maintenance

Gasoline Powered Centrifugal Pump

Grease cup instructions (Fig.5a)

GREASE CUP NEEDS TO BE CLEANED REGULARLY

The grease cup may not perform its function properly (lubricating the seal) if it is not routinely cleaned of old hard grease build-up.

If the grease cup is always “topped up” instead of allowed to run to the full stroke of the plunger, the grease may dry out and build up inside of the cup and not allow the plunger to push to the full stroke. This in turn will stop the supply of grease to the seal causing premature seal failure.

As a precaution it is strongly recommended that every 30 days, the grease cup (or the top of the grease cup) be removed and the inside of the cup and the plunger be cleaned of all old grease.

Reassemble the plunger into the cup and check that the plunger slides to the bottom of the now clean cup.

Fill with fresh grease.

FIG #5a Shows clean grease cup & plunger and old, dried grease taken out of the cup, that was causing the plunger to “hang-up”.

Fig. 5a



M-500G

Description, Care and Maintenance

Filter / Shear System

The filter / shear (Fig.6a) system on the M-500 is an integral part of the mixing system and to operate efficiently requires daily cleaning of the stainless steel internal filter /shear. The filter / shear system is a two-piece unit (Fig.6b) consisting of an outside housing and an internal filter / shear. The filter / shear will trap any debris, such as parts of bags, stones, leaves grass etc. The proper procedure for cleaning the filter / shear is to close the suction valve from the reservoir tank to the pump, Rotate the “Tank Gun” & “Drill Fluid” valves to the closed position, remove the 5 inch Snap Loc coupler at the right end of the filter housing, remove the 3 inch Snap Loc coupler at the discharge port of the centrifugal pump. You will now be able to remove the internal filter / shear from the housing, after the internal filter / shear has been removed, you will see on the end of the filter / shear an end cap (Fig.6b). Remove the end cap and wash out the filter / shear with clear water. Reinstall the end cap on the filter / shear, reinstall the filter / shear in the housing (*Note the small block on the bottom of the screen, this is placed on the bottom of the filter housing to aid lining up the 5 inch Snap Loc coupler and gasket*) **do-not** clamp the 5 inch coupler until the 3 inch coupler and gasket are properly lined up. After all pieces are correctly lined up, clamp the 5 inch coupler 1st and 3 inch coupler 2nd and reinstall the safety pins. Open all of the valves that were close prior to removing the filter / shear.

Housing

Fig.6a

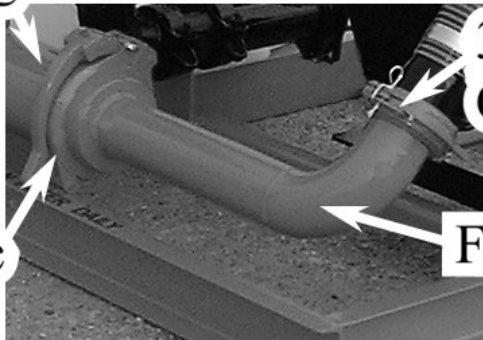

3" Snap Loc Coupler

5" Snap Loc Coupler

Filter/Shear

Fig.6b

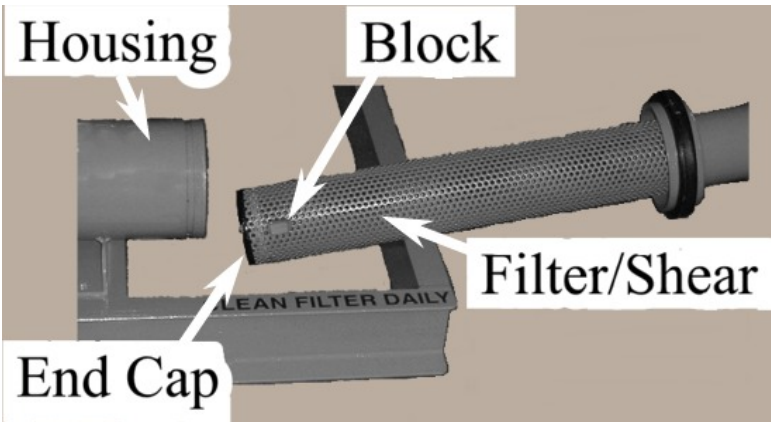

Housing

Block

Filter/Shear

End Cap

⚠ DANGER

NEVER ATTEMPT REPAIRS OR DISASSEMBLY
without shutting off the engine / motor and disconnecting the power source. Serious personal injury will result.

⚠ WARNING

NEVER ATTEMPT TO REMOVE OR CLEAN THE FILTER SHEAR
while the unit is in operation. Serious personal injury will result.

CAUTION

CARE MUST BE TAKEN WHEN INSTALLING THE COUPLER GASKETS. If the gaskets are not properly lubricated and installed, a leak may develop.

M-500G

Description, Care and Maintenance

Filter / Shear System *continued*

On top of the filter / shear housing (Fig.7) are two outlets that have 1 1/2” NPT ball valves connected to them. One of the outlets (labeled) is connected to the internal jet gun inside of the reservoir tank (explained further on in this manual) and the other outlet (labeled) is to be used as a discharge for the fluid after it is mixed. The discharge can be connected to another reservoir tank or directly to the drill rig. To control the flow of discharge, the ball valve can be used to regulate the flow. The speed of the engine can also be used to control the flow and pressure of the discharge. It is up to the customer to decide the piping arrangement and how they would use the discharge options. The discharge flow can have high pressure and high volume flows associated with it, and should be treated as such. If you are unsure of the installation and routing of this flow, contact Surface to Surface Inc. for more details.

Also on top of the housing is the outlet for the wash wand. The wash wand is explained in more detail further on in this manual

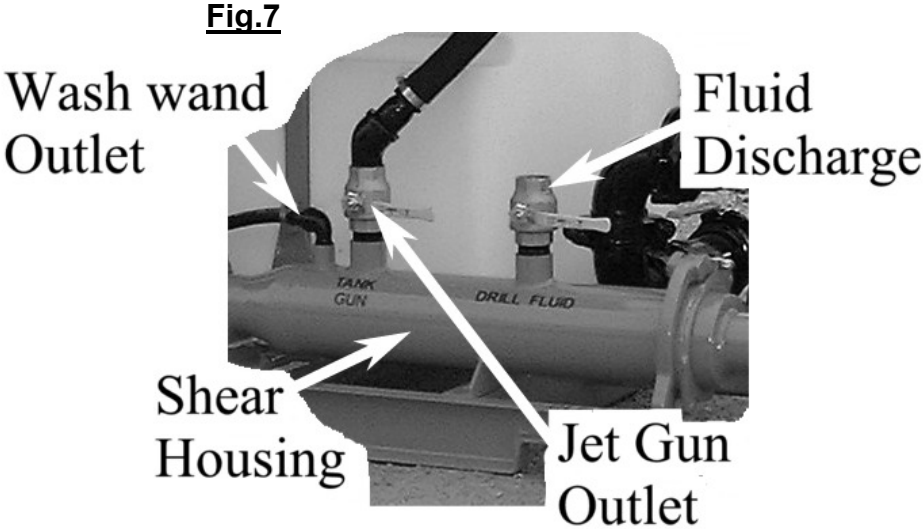

CAUTION

WHEN TRANSFERRING FLUID to the drill rig, fluid pressure may reach or exceed 50 p.s.i. CHECK the drill rig manufacturers specifications regarding maximum inlet pressures allowed for their pump.

CAUTION

TRAPPED FLUID MAY BE PRESENT and will spill out when piping, hoses, pump or filter shear are removed.

M-500G

Description, Care and Maintenance

Venturi Mixing Tee

The Venturi Mixing Tee (Fig 8a.) is the very heart of this system and requires very little maintenance. However M-500 parts may wear as a result of the application in time and require replacement. This wear will become evident, when the operator notices a reduction in the vacuum that helps pull in the dry product from the hopper. When mixing dry product, over time, you will see an accumulation of damp product inside of the mixing tee around the nozzle. If this accumulation is left unattended, over time it will build to the point of restricting the inlet of the mixing chamber. This situation is easily rendered, by using the wash wand to “flush out the accumulation, and force it back into the fluid stream.

Fig.8a

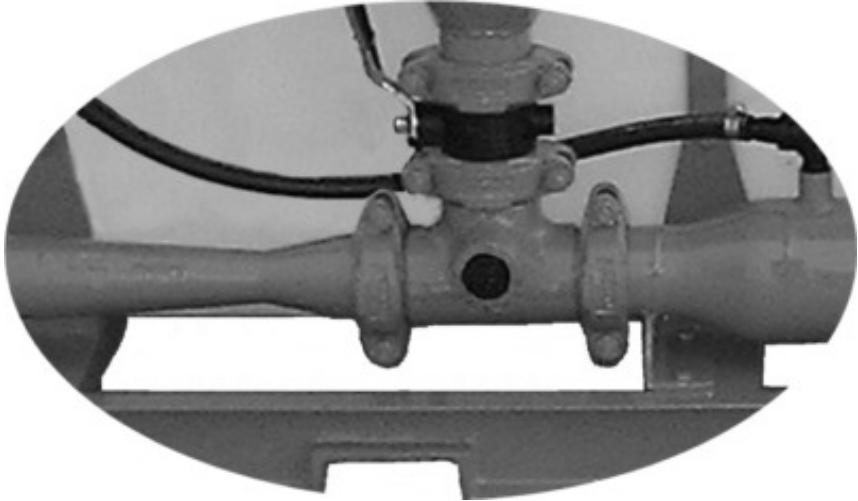

CAUTION

AVOID ALLOWING FOREIGN MATERIAL into the Venturi Mixing Tee thru the Hopper, by keeping the valve closed when not in use.

Fig.8b

⚠ WARNING

NEVER USE BODY PARTS, OR FOREIGN OBJECTS in an attempt to unplug or clean the hopper valve or mixing tee. Serious personal injury or damage will result.

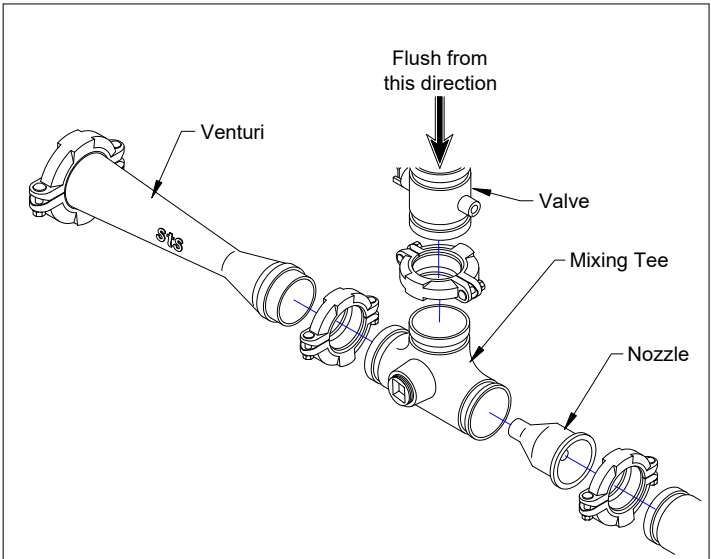

M-500G

Description, Care and Maintenance

Wash Wand

The M-500 is equipped with a pressurized wash wand (Fig.9a) for clearing obstructions and accumulation in the jetting tee. It is recommended that the jetting tee be cleaned with the wash wand after the introduction of material into the hopper after each batch.

The wash wand uses the high-pressure fluid from the mixing system piping which can reach pressures of up to 50psi. **CAUTION** should always be used when handling the wash wand. A valve is located on the wash wand to regulate the flow of fluid.

The wash wand is not to be used as a poker or pry bar, but instead use the fluid from it to “wash” away accumulations. Be careful when putting the wash wand inside the mixing chamber that it does not block the fluid stream coming out of the nozzle, as it will spray back up the hopper and towards the operator.

The wash wand can also be used to get a fluid sample for testing purposes. An example of this (Fig.9b) is to check the viscosity of the fluid using a marsh funnel. Simply slow the engine speed down to reduce flow and pressure, and put the wash wand inside the hopper (with the hopper valve open) and open the small valve located on the wash wand. Rotate the valve handle to the on position, and let it flow for approx. 15 seconds, close the valve and place the wash wand in the screening area of the marsh funnel. Fill the marsh funnel to the proper volume, close the valve on the wand, and store back the small hose holder rack. Follow the instructions of the march funnel for the rest of the test.

The sample of fluid taken from the wash wand is the same as the fluid going out of the top discharge of the filter / shear housing to the drill rig or reservoir tank.

Fig.9a

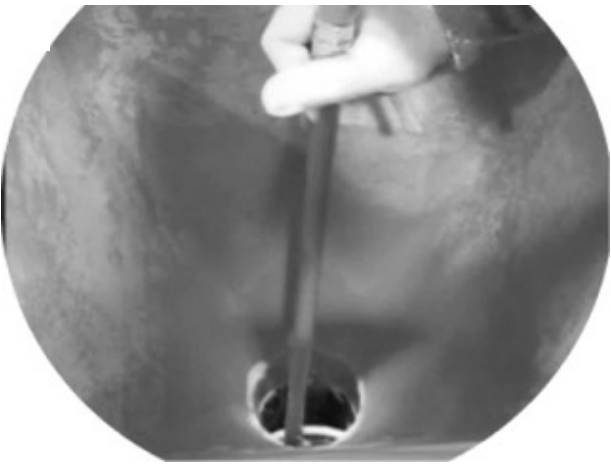

⚠ CAUTION

DO NOT POSITION ANY PART OF YOUR BODY over the hopper, valve, or mixing tee while cleaning.

⚠ CAUTION

WHEN THE UNIT IS IN OPERATION, the fluid in the piping may reach pressures up to 50 p.s.i. When the engine is idling, the system is still pumping fluid under pressure.

⚠ WARNING

NEVER USE BODY PARTS, OR FOREIGN OBJECTS in an attempt to unplug or clean the hopper valve or mixing tee. Serious personal injury or damage will result.

Fig.9b



M-500G

Description, Care and Maintenance

Dry Hopper with Table and Hopper Valve

The Dry Hopper and Table (Fig.10) are used during the initial mixing of the dry product and fluid. The hopper and table require very little daily maintenance, however care should be used that this unit does not become overloaded. There should never be more than 100 lb. in or on the hopper and table at any time. The hopper and table are not ladders and should not be climbed on or sat on, damage can result. The hopper valve must be kept free of dried Bentonite, ice or other buildups to reduce the chance of damage during opening and closing. The valve operates more smoothly if the surfaces are kept damp or wet. All valves are to be opened and closed by hand. **DO NOT FORCE THE VALVE OPEN OR CLOSED**, visually check the valve if a problem occurs!

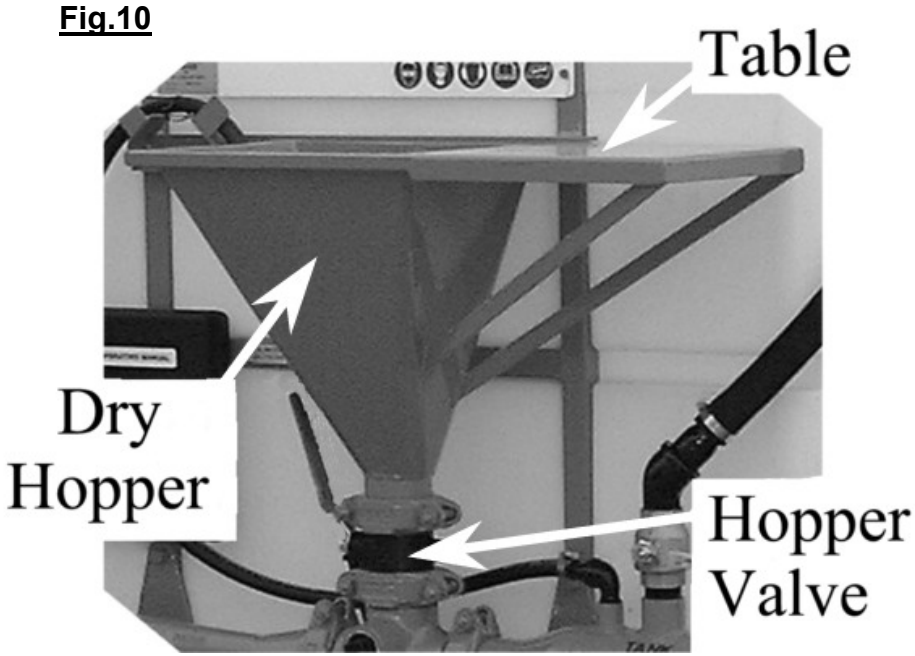

⚠ WARNING

NEVER USE BODY PARTS, OR FOREIGN OBJECTS in an attempt to unplug or clean the hopper valve or mixing tee. Serious personal injury or damage will result.

⚠ CAUTION

DO NOT POSITION ANY PART OF YOUR BODY over the hopper, valve, or mixing tee while cleaning.

CAUTION

AVOID ALLOWING FOREIGN MATERIAL into the Venturi Mixing Tee thru the Hopper, by keeping the valve closed when not in use.

M-500G

Description, Care and Maintenance

Internal Tank Jet Gun

The Internal Jet Gun (Fig.11a) is located inside the polyethylene plastic reservoir tank, and its function is to keep the slurry product in the tank moving. This function assures the elimination of dead spots in the tank and a consistent mixture of fluid. The internal jet gun control valve labeled “Tank Gun” (Fig.11b) should always be in the open position, unless you are cleaning the filter / shear (described earlier) or performing repairs on the system. If the valve is not closed a siphoning action can occur, pulling fluid from the tank and into the external piping. The jet gun requires little or no maintenance and will only require attention if the jets become clogged. Flushing the entire system weekly with clear water should eliminate any problems with this piece of the system. The fluid from the Jet Gun is at a very high pressure and extreme caution should be used when removing and viewing through the small vent cap on the tank lid.

The tank jet gun also acts as relief valve to the system and relieves the pressure spikes caused when the flow to the drill rig or reservoir tank is interrupted.

Fig.11a

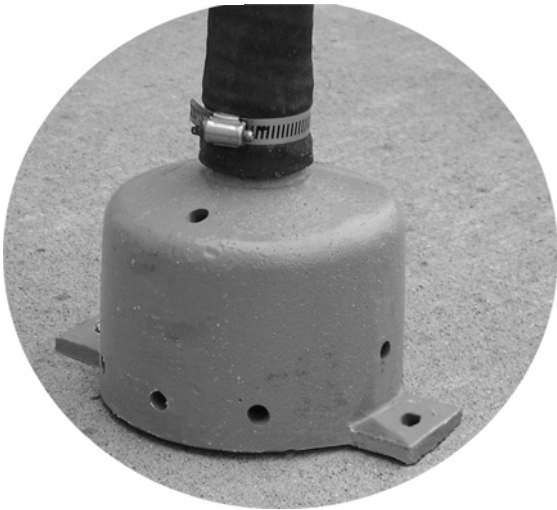
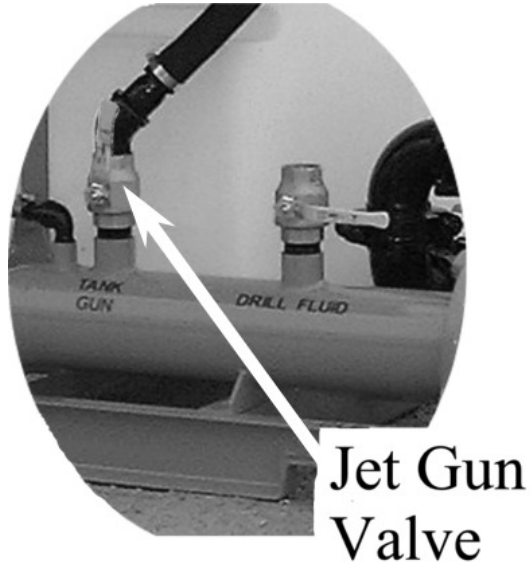



Fig.11b



 DANGER
NEVER ATTEMPT REPAIRS OR DISASSEMBLY without shutting off the engine / motor and disconnecting the power source. Serious personal injury will result.

CAUTION
TO ENTER THE TANK is not recommended. Personal injury could result from the presents of hazardous fumes, remaining fluid or unit start-up.

 CAUTION
NEVER OPERATE THE MIXING unit with the tank lid open. If viewing is necessary, open only the small inspection vent cap in the center of the lid.

 CAUTION
WHEN THE UNIT IS IN OPERATION, the fluid in the piping may reach pressures up to 50 p.s.i. When the engine is idling, the system is still pumping fluid under pressure.

SECTION #III

Set-up and Installation of Unit in Detail

M-500G

Set-up and Installation of M-500 in detail

Permanent mounting of the unit

The M-500 is built on a sub frame that can be bolted down to a permanent surface like a concrete pad, pull type trailer, flat deck of a truck or inside of a truck body. Securing the unit with adequate size and grade of fasteners is the sole responsibility of the customer and not of Surface to Surface Inc.

There are four mounting holes located inside of the fork tubes (Fig.12) to fasten the sub frame down. These are structurally designed to hold and withstand any movement of the unit when properly sized fasteners are inserted into the holes. When fastening down the unit, care should be used when drilling holes into the surface below to avoid such unseen items, as gussets, cross-members, wiring or other fixtures below the surface.

Adequate space or an opening will also have to be considered when mounting, for the removal of the filter / shear cartridge for regular cleaning and inspection.

Be aware of the engine exhaust and how it will impact on the placement of the unit. If the unit is to be mounted in an enclosed area the exhaust will have to be vented outside where it will not effect the health of the operator or others working near the unit.

Portable use of the unit

If the M-500 is to be used as a portable unit, there are fork tubes to slide the forks of the appropriate size lift truck under the main skid frame (Fig.12). Make sure that the mixer is properly balance on the forks before lifting or moving. Placing the forks into the tubes under the main skid frame **DOES NOT secure the unit to the forks when lifting or moving, therefore the unit should be secured to the forks with chain, cable or other fastening devices that will restrict movement.**

The M-500 should always be placed on solid, level ground with a clear working area around it.

Fig.12



CAUTION
LIFTING LUGS OR THE LIFTING POINT(S) identified and labelled on the skid structure must be used in order to safely lift and transport the unit.

CAUTION
BEFORE LIFTING OR MOVING THE UNIT, all fluid should be removed from the tank.

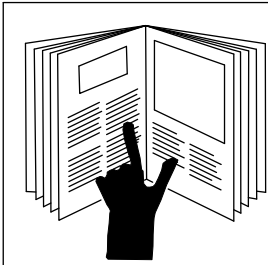

WARNING
REFER TO THE SAFETY STATEMENTS IN THE ENGINE OEM MANUAL AND THIS MANUAL REGARDING THESE OPERATIONS.

SECTION #IV

Operating the M-500 Unit



M-500G

Operating the M-500 Unit

Site Setup & Pre-Check

SITE SETUP

- **CHECK** for overhead hazards if unloading the unit to the ground.
- **UNLOAD** the unit by using the sub frame fork pockets (marked) with appropriate equipment.
- **SET** and position the unit on solid level surface to avoid settling or upset.
- **SET** and position the unit to have a clear unobstructed working area of 10ft (3m) on all 4 sides.
- **CONNECT** and secure all hoses onto the unit according to your layout.
- **SECURE** the truck and/or the trailer that the unit is mounted on, from movement.
- **PROTECT** any hose(s) that connect between the M-500 and the drill rig, from possible damage or from being driven upon by a vehicle.

UNIT PRE-CHECK

- **READ** engine operators manual for proper starting and running procedures.
- **CHECK** to ensure the engine oil level is correct. Refer to the engine operator manual supplied.
- **CHECK** to ensure the air filter is clean (replace if necessary). Refer to the engine operator manual supplied.
- **CHECK** to ensure the fuel tank is full and the shut off valve is open. Refer to the engine operator manual supplied.
- **CHECK** to ensure the grease cup on the pump is full of grease and the winged/lugged nut on the top, is backed off to allow the shaft to retract into the grease cup.
- **CHECK** to ensure any valves installed on the suction intake line between the tank and centrifugal pump are open.
- **CHECK** to ensure there is sufficient fluid in the tank, to insure the centrifugal pump does not run dry.
- **CHECK** to ensure the centrifugal pump is primed.
- **CHECK** to ensure the ball valve on the filter housing marked “Tank Gun” is open.
- **CHECK** to ensure the ball valve on the filter housing marked “Drill Fluid” is closed.
- **CHECK** to ensure the small ball valve connected to the Wash Wand is closed.
- **CHECK** that the hopper valve is closed.

M-500G

Operating the M-500 Unit

Starting the Engine & Pump

***** The Engine Operators Manual should be consulted for a more detailed engine start up procedure for both recoil and electric start engines**

Starting Engine (Recoil Start)

- Move the Fuel & ignition lever or Fuel shut off to the on or start position.
- Set the speed control lever to the fast position.
- If the engine is cold or the ambient temperature is low, move the choke lever to the closed position.
- If the engine is warm or the ambient temperature is high, close the choke lever half-way, or keep it fully open.
- Pull the starter recoil handle slowly until resistance is felt. This is the compression point. Return the starter recoil handle to its original position and pull swiftly. Do not pull out the rope all the way. After starting the engine, allow the starter recoil handle to return to its original position while still holding the handle.
- After starting the engine, gradually open the choke until fully open. Do not fully open the choke lever immediately when the engine is cold or the ambient temperature is low, or the engine may stop.
- After the engine starts, set the speed control lever at the low speed position and warm it up without load for a few minutes.
- Remember that the system is pumping water under pressure, even when the engine is idling.
- Gradually move the speed control lever toward the high-speed position. *Note: Whenever high-speed operation is not required, slow the engine down by moving the speed control lever to save fuel and extend engine life.*

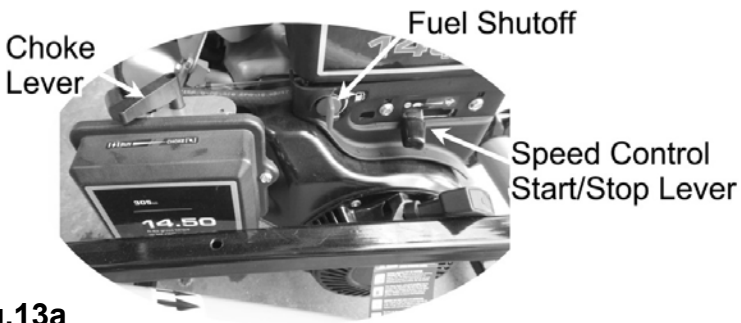

Fig.13a

Note The Gorman Rupp pump used on this unit is self-priming. Re-priming is not required as long as the pump is kept full of liquid and the hoses are not unhooked and / or drained.

	<p>WARNING</p>
	<p>REFER TO THE SAFETY STATEMENTS IN THE ENGINE OEM MANUAL AND THIS MANUAL REGARDING THESE OPERATIONS.</p>

<p>CAUTION</p>
<p>BEFORE STARTING THE ENGINE, BE SURE THE PUMP IS PRIMED! Check the pump by slowly & carefully opening the plug located on the top of the centrifugal pump discharge elbow. A visual inspection can be made if the fluid escapes around the plug as it is loosened. Remove the plug to view inside fluid level. The centrifugal pump seal WILL be damaged if allowed to cavitate or run dry.</p>

M-500G

Operating the M-500G Unit

Typical Mixing Operation

Mixing Operation

- Operate the engine at high speed.
- Open the hopper valve at the bottom of hopper where it joins the venturi mixing tee.
- Introduce the dry or liquid raw material into the hopper.

When mixing a new batch, introduce the 1st bag of dry product at a rate of 40 lbs per minute. Once the first 40 lbs. of dry product are in the fluid stream, all dry products may be introduced as fast as the hopper will allow. This allows time for the 1st bag to be mixed well into the fluid and will now aid to suspend all remaining dry product that is added, in the fluid in the tank to achieve a better shear and stop any build-up in the tank.
- Suction created by the venturi mixing tee will draw the raw material into the jet stream for initial mixing.
- Flush jetting tee with wash wand.
- Close the butterfly valve on the hopper to keep debris out of the system.
- Allow the mixing system to circulate the product until the desired consistency is attained.
- A sample of the mixed fluid may be taken at from the wash wand as described earlier in this manual, on the wash wand description page.

***Note:** Whenever high-speed operation is not required, slow the engine down by moving the engine speed control lever to save fuel and extend engine life.*

 DANGER
IN AN EMERGENCY rotate the engine switch to the STOP position to halt engine, pump, and fluid flow

CAUTION
AVOID ALLOWING FOREIGN MATERIAL into the Venturi Mixing Tee thru the Hopper, by keeping the valve closed when not in use.

 WARNING
NEVER USE BODY PARTS, OR FOREIGN OBJECTS in an attempt to unplug or clean the hopper valve or mixing tee. Serious personal injury or damage will result.

 CAUTION
NEVER OPERATE THE MIXING unit with the tank lid open. If viewing is necessary, open only the small inspection vent cap in the center of the lid.

 CAUTION
DO NOT POSITION ANY PART OF YOUR BODY over the hopper, valve, or mixing tee while cleaning.



 WARNING
REFER TO THE SAFETY STATEMENTS IN THE ENGINE OEM MANUAL AND THIS MANUAL REGARDING THESE OPERATIONS.

M-500G

Operating the M-500 Unit

Typical Transfer/Offloading Operation

Transferring Operation

- On the top of the filter / shear housing of the M-500 you will see a 1-1/2 in. ball valve (1-1/2”NPT.) marked “Drill Fluid”.
- A transfer hose with a minimum size of 1-1/2 in. can be attached to the ball valve to carry the finished product to a holding tank or directly to the drill rig.
- Make the necessary connections at the holding tank or the drill rig.
- Run the M-500 pump at a favorable speed and slowly rotate the ball valve handle to the open position, to allow the fluid to flow to the holding tank or the drill rig.
- The speed and pressure of the fluid flow is determined by the engine speed.
- If the unit is supplying the drilling rig directly, a valve that is controlled by the operator of the drill rig, will be needed to stop the flow. The jet gun valve will need to be in the open position to act as a “relief” when the valve on the drill rig is closed.
- If transferring to a reservoir tank, the valve on top of the filter/shear housing is used to start / stop the flow of fluid.
- When removing the mixed fluid from the tank (to the drill rig or reservoir), leave approximately 4” of fluid in the bottom of the tank to keep the pump from sucking air (cavitation).
- Close the “Drill Fluid” valve, add water to the tank and begin mixing a new batch of mixed fluid.

 **DANGER**

IN AN EMERGENCY
rotate the engine switch to
the STOP position
to halt engine, pump, and fluid flow

CAUTION

WHEN TRANSFERRING FLUID
to the drill rig, fluid pressure may
reach or exceed 50 p.s.i.
CHECK the drill rig manufacturers
specifications regarding maximum inlet
pressures allowed for their pump.

 **CAUTION**

**WHEN THE UNIT
IS IN OPERATION,**
the fluid in the piping may reach
pressures up to 50 p.s.i.
When the engine is idling, the system is
still pumping fluid under pressure.

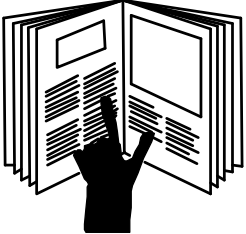
 **WARNING**

REFER TO THE SAFETY
STATEMENTS IN THE
ENGINE OEM MANUAL
AND
THIS MANUAL
REGARDING THESE
OPERATIONS.



M-500G

Operating the M-500 Unit

Typical Warm Weather Shutdown & Storage

Daily Shut Down

- Set the engine speed control lever (Fig.13a) at the low speed position and allow the engine to run at low speed for 5 minutes.
- Slide the engine switch to the off position. Do not stop engine suddenly while running at high speed.
- Close the fuel cock.
- Pull the recoil starter handle slowly until resistance is felt and then return the handle to its original position. *Note - This operation is necessary to prevent outside moist air from intruding into the combustion chamber.*
- Close the valve on the suction line between the tank and the pump.
- If fluid is left in the tank, rotate the “tank gun” valve to the closed position.
- Remove the filter / shear as described in maintenance section.
- Clean filter / shear as described in maintenance section.

Additional Week End Shut Down

- Pump or drain remaining mixed fluid out of the tank and dispose of it according to local environmental approved practices.
- Make sure “Tank Gun” and “Drill Fluid” valves are open.
- Fill and rinse the tank with clear water and then start the engine and pump. By pumping this water through the system, it will remove buildup and dilute any remaining mixed fluid in the system. Open the valve on the wash wand to flush it.
- Stop the engine and pump.
- Drain the remaining water out of the tank and dispose of it according to local environmental approved practices.
- Remove the drain cap on the suction tee located at the lower right end of tank and allow remaining water to escape from the piping. After draining, replace the cap.
- Remove centrifugal pump front drain plug. Replace the plug when the pump is empty.
- Make sure “Tank Gun” and “Drill Fluid” and wash wand valves are open.
- Remove filter / shear and clean as described in the maintenance section of this manual.
- Using a wet/dry vacuum, vacuum remaining water and debris from the polyethylene plastic reservoir tank.

⚠ DANGER
NEVER ATTEMPT REPAIRS OR DISASSEMBLY
 without shutting off the engine / motor and disconnecting the power source. Serious personal injury will result.

CAUTION
 TO ENTER THE TANK is not recommended
 Personal injury could result from the presents of hazardous fumes, remaining fluid or unit start-up.

CAUTION
 CARE MUST BE TAKEN WHEN INSTALLING THE COUPLER GASKETS. If the gaskets are not properly lubricated and installed, a leak may develop.

CAUTION
 TRAPPED FLUID MAY BE PRESENT and will spill out when piping, hoses, pump or filter shear are removed.

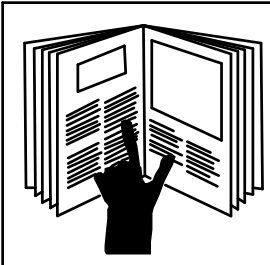

⚠ WARNING
 REFER TO THE SAFETY STATEMENTS IN THE ENGINE OEM MANUAL AND THIS MANUAL REGARDING THESE OPERATIONS.



M-500G

Operating the M-500 Unit

Typical Cold Weather Shutdown & Storage

Additional Winter and Freezing Weather Shut Down

- Pump or drain remaining mixed fluid out of the tank and dispose of it according to local environmental approved practices.
- Make sure “Tank Gun” and “Drill Fluid” valves are open.
- Fill and rinse the tank with clear water and then start the engine and pump. By pumping this water through the system, it will remove buildup and dilute any remaining mixed fluid in the system. Open the valve on the wash wand to flush it.
- Stop the engine and pump.
- Drain the remaining water out of the tank and dispose of it according to local environmental approved practices.
- Remove the drain cap on the suction tee located at the lower right end of tank and allow remaining water to escape from the piping. Leave the cap off.
- Remove centrifugal pump front drain plug. Leave the pump plug out.
- Make sure “Tank Gun” and “Drill Fluid” and wash wand valves are open.
- Remove filter / shear and clean as described in the maintenance section of this manual. Leave filter / shear out of housing as this will allow remaining moisture to drain.
- Open the hopper valve and pour in a suitable environmentally friendly anti-freeze until it runs out of the filter / shear housing opened end.
- Shut the hopper valve and pour a suitable environmentally friendly anti-freeze into the hopper until about 2” of fluid cover the valve. This will stop the valve from freezing around the edges.

CAUTION
NEVER LEAVE LIQUID IN THE PUMP CASING, PIPING, OR HOSES during freezing weather conditions, as damage will result. Follow instruction for winterizing.

CAUTION
CARE MUST BE TAKEN WHEN INSTALLING THE COUPLER GASKETS. If the gaskets are not properly lubricated and installed, a leak may develop.

CAUTION
TO ENTER THE TANK is not recommended Personal injury could result from the presents of hazardous fumes, remaining fluid or unit start-up.

	WARNING
	REFER TO THE SAFETY STATEMENTS IN THE ENGINE OEM MANUAL AND THIS MANUAL REGARDING THESE OPERATIONS.

M-500G

Operating the M-500 Unit

Prolonged Periods of Storage

Prolonged Periods of Storage

After a thorough cleaning of the internal and external components of the M-500, the following steps should be applied to extend the life of your unit.

- Prolonged periods of storage require extra care of the pump to protect from rusting internally. Separate the pump (as you would to replace the seal) to dry and spray with a protective oil film.
- Prolonged periods of storage require engine preparation. See engine operator's manual.

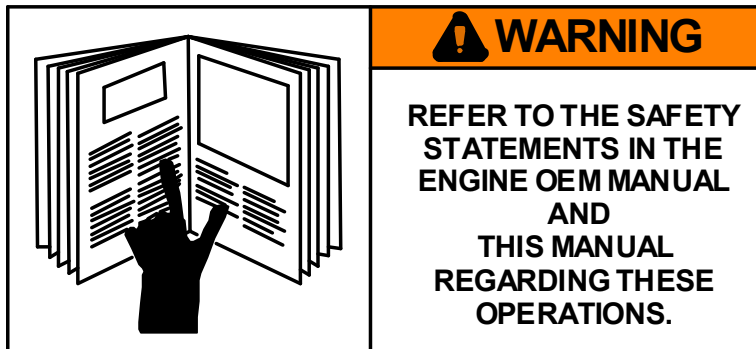

M-500G

Operating the M-500 Unit

Optional Self-Loading Feature

Self-Loading (customer to install)

If the self-loading feature of The M-500 is required, you will find a 1-1/2 in. NPT (suction) port located on the venturi-mixing tee below the hopper valve (Fig.14a). All units are shipped with a plug installed in the port.

A common practice is to use this “suction port” to draw fresh water from another reservoir tank. As shown in (Fig.14b) remove the plug and install an elbow, close nipple, full flow ball valve and a type of quick coupler capable of being capped when not in use OR a hose barb and a non-collapsing hose (*hard hose*) can then be installed as a permanent connection **AFTER** the valve.

Caution should be used when threading in a connection into the suction port. Do not over tighten the Regardless of the configuration of the connection used, this port needs to be sealed off (valve or capped) when not being used as a suction port. The reason for this is that then the unit is shut off, fluid will fill the mixing tee and spill out the port or when the unit is in operation, it will draw air and a decrease the vacuum at the hopper inlet.

When the unit is mixing product from the hopper, this port will need to be closed. If you are using this port for suction, the hopper valve is to be closed. **THIS MEANS YOU CANNOT “MIX ON THE FLY” OR MIX AND SUCK AT THE SAME TIME!**

If the suction port is connected (as described above) but not used frequently, a build-up of dry product may form inside the port at the mixing Tee. The wash wand can usually wash this out. If you notice a decrease or stoppage in the amount of fluid being drawn in to the system through this port, then there is build-up at the port and should be cleaned.

Fig.14b

Fig.14a

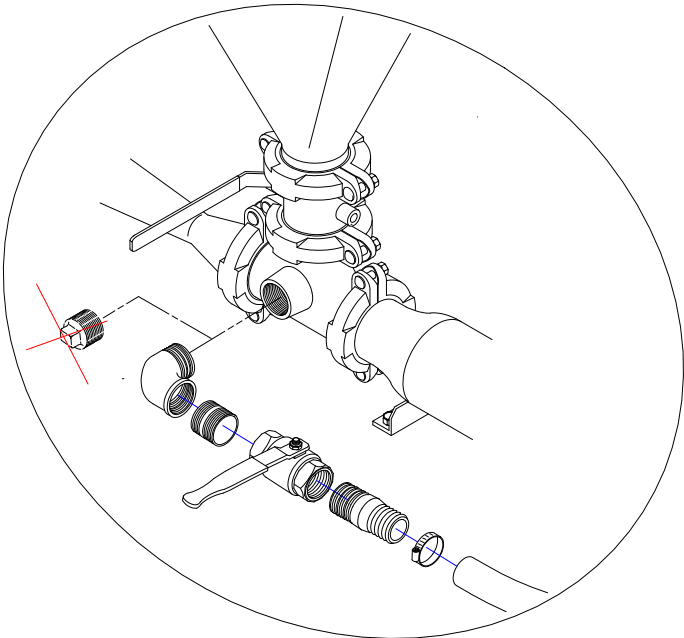
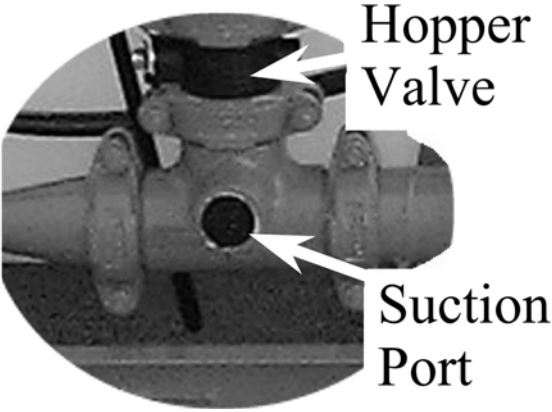

SECTION #V

Troubleshooting the M-500 Unit

M-500G

Troubleshooting the M-500 Unit

The M-500 mixing unit is of a simple design with limited moving parts or consumable pieces. The basic system works with a pump that draws fluid from a reservoir tank. The fluid then exits the pump and by building pressure, and velocity, forces the fluid through the filter / shear and into the mixing Tee. The fluid enters the mixing Tee through a nozzle and exists through a venturi. As the fluid enters the venturi, it creates a vacuum in the mixing tee to aid in introducing the dry product from the hopper into the mixing Tee and fluid stream. As the fluid passes through the venturi it carries the dry product with it and into the reservoir tank.

As the fluid travels through the filter / shear, a set amount of fluid is taken from that fluid stream and forced with pressure, to the jet gun inside the reservoir tank. The jet gun has multiple outlets that distribute the fluid throughout the tank to “stir up the tank bottom.

The M-500 can discharge fluid to the drill rig or another reservoir by allowing some fluid from the filter shear to be discharged and controlled by a valve.

**A good rule to follow when troubleshooting is as follows
Everything before the pump is being sucked, “has vacuum”.
Everything after the pump is being blown, “has pressure”.**

The following, may aid in any problems that may arise.

- *No fluid flow/ low fluid flow*
 - Pump not primed. - Prime pump
 - Suction valve is closed - Open suction valve
 - Suction valve is broken and not opening inside properly. - Replace valve
 - Plugged suction inlet inside of the tank. - Clean build-up inside of the tank
 - Not enough fluid in the tank or cavitation - Add fluid to tank
 - Impeller wore and gap to big. - Shim the impeller or remove gaskets
 - Pump speed to slow. - Speed up pump
 - Blockage in pump. - Remove blockage
 - Fluid too thick to pump. - Thin fluid by adding more water.
 - Filter / shear is plugged. - Clean filter shear
 - Optional Mixing Tee valve closed. - Open Mixing Tee valve

- *Fluid backs up into hopper*
 - No fluid flow / low fluid flow - See above solutions
 - Large build-up in mixing Tee - Clean mixing Tee
 - Blockage in small part of venturi. - Remove blockage in venturi
 - Pump speed is set to low - Increase speed of the pump.
 - Mixing Tee suction port is open - Close off valve or cap (customer installed)

- *Dry product is slow or will not be drawn down through the hopper.*
 - No fluid flow/ low fluid flow - See above solutions
 - Fluid is backing up into hopper - See above solutions
 - Dry product has lumps / debris blocking hopper valve - New product or clean valve
 - Hopper valve closed - Open hopper valve
 - Buildup in throat of mixing Tee - Clean throat of mixing Tee



M-500G

Troubleshooting the M-500 Unit

- *Tank does not stir / roll the fluid inside.*
 - No fluid to the tank jet gun** - Make sure “Tank Gun” valve is open.
 - Tank jet gun holes plugged.** - Flush fresh water through system or clean Tank jet gun
 - Hose is disconnected from tank jet gun** - Reconnect hose
 - No fluid flow/ low fluid flow** - See above solutions
- *Discharge from the unit is slow or stopped.*
 - “Drill Rig” discharge valve is closed** - Make sure “Drill Rig” valve is open.
 - Discharge hose is blocked, kinked, or pinched off.** - Repair problem(s) with hose.
 - A valve installed at the end of the discharge hose is closed or damaged.** - Open or replace valve.
 - No fluid flow/ low fluid flow** - See above solutions
- *Wash wand has little or no flow or pressure.*
 - Wash wand valve is closed or damaged** - Open wash wand valve or replace.
 - Wash wand nozzle (hole in the end) is plugged** - Shut off unit and clean out wash wand hole.
 - No fluid flow/ low fluid flow** - See above solutions
- *Fluid does not seem to mix well or is slow to mix*
 - Most of the above problems will cause poor mixing or slow mixing** - See above solutions.
- *Engine will not start*
 - See engine operator’s manual for trouble shooting engine.**

For problems that can not be solved by the above steps, call your local distributor or STSI (1-800-567-0978) and talk to a company representative who would be glad to assist you with your problem.

SECTION #VI

Periodic Maintenance & Repair Information

Basic M-500 Gasoline Periodic Maintenance Schedule ***

Consult the OEM engine manual for a more detailed maintenance schedule

<i>Engine Components</i>							
Maintenance Items	Every 8 hours (daily)	Every 50 hours (weekly)	Every 100 hours	Every 200 hours (monthly)	Every 300 hours	Every 400 hours	Every 2000 hours (or yearly)
Visual check of engine for oil, fuel leaks	0						
Clean engine and check bolts & nuts	0						
Check engine oil level & top-up if necessary	0						
Check fuel level and top up	0						
Replace engine oil <i>(initial first 5hr)</i>		0					
Check battery fluid level (if applicable)		0					
Clean & Gap spark plugs		0				0 replace	
Clean air filter, pre cleaner & replace when necessary		0		0 replace			
Check spark arrester for clogging and clean		0					
Lube pivot point & linkage pins on throttle control			0				
Clean or replace fuel filter				0			
Check and readjust valve clearance							0
** The above engine items have been listed as basic items to check. A full and complete maintenance schedule is listed in the accompanying OEM engine manual and should be followed. STSI is not to be held liable for any discrepancies or errors in the above schedule.							
<i>Pump Components</i>							
Check General Condition Visual (Temperature, Unusual Noise or Vibrations, Cracks, Leaks, Loose hardware).	0						
Check & Fill grease cup for mechanical seal	0						
Check pump mechanical seal for leakage (dripping)	0						
Clean old grease build-up from inside of grease cup				0			
Check front impeller clearance (wear plate)						0	
Check rear impeller clearance (seal plate)						0	
Inspect the check valve						0	
<i>Equipment Components</i>							
Wash out Jetting Tee	0						
Remove & clean shear unit	0						
General Condition Visual (Cracks, Leaks, Loose hardware)	0						
Clamps are tight and safety pins installed	0						
Lube valve stems		0					
Clean reservoir tank of build-up (internal)			0				
Disassemble and visually inspect piping (internal)							0

M-500G

Grease Seal Installation Instructions Centrifugal Pump Application

When replacing the sea, never mix old and new parts. Wear patterns on the old seal faces cannot be realigned during reassembly, and use of old parts can result in premature failure of the new seal.

Before installing the seal, inspect the bore of the seal liner for excessive wear or grooves that might cause leakage or damage to the seal packing rings. If the seal liner must be replaced, use the new seal liner and arbor (or hydraulic) press to force the old one out. After the liner is installed, drill a 3/8" diameter hole through it to permit the flow of lubricant to the seal liner. Be Careful to center the drill in the threaded lubrication hole so not to damage the threads. Debur the hole from the inside of the seal liner after drilling.

Clean the seal cavity and shaft with a cloth soaked in fresh cleaning solvent. Be sure to follow all safety precautions described on the solvent container.

Remove the new seal and inspect the precision finished faces to ensure that they are free of any foreign matter. To ease installation of the seal, lubricate the packing rings, spacer sleeve, and seal liner with water or a very small amount of oil and apply a drop of light lubrication oil on the precision finished faces. Refer to the illustration, and assemble the seal as follows.

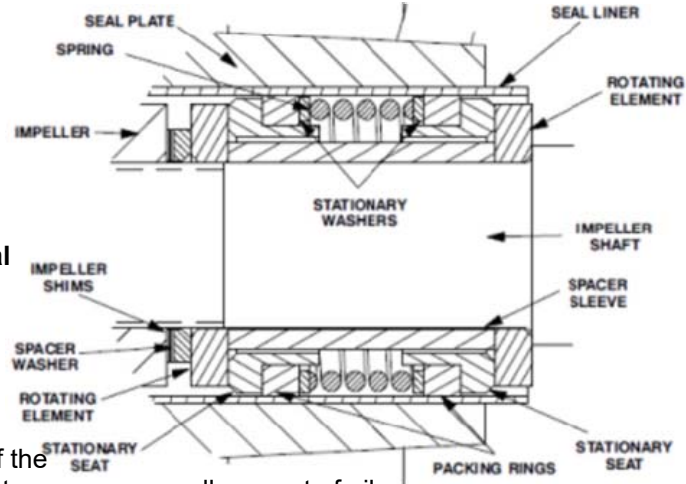

Installation of the inboard rotating element is dictated by the configuration of the shaft shoulder. If there is a radius at the shaft shoulder, the larger chamfer on the I.D. of the inboard rotating element must be positioned toward the shaft shoulder. If there is an undercut at the shaft shoulder, the larger chamfer must be positioned away from the shaft shoulder. Determine the correct position for the rotating element and slide it onto the shaft.

Sub assemble the inboard stationary element, packing ring and spring washer, and press this subassembly into the lubricated seal liner. A push tube cut from a length of plastic pipe or a properly sized deep socket will aid seal installation. The O.D. of the tube should be about the same size as the O.D. of the seal spring.

Install the spacer sleeve and spring.

Sub assemble the outboard stationary element, packing ring and spring washer. Press this subassembly into the lubricated seal liner. If the outboard rotating element has a chamfered side, install it with the chamfer facing the impeller end of the shaft.

If your pump requires a spacer washer, install the spacer washer with the chamfer on the I.D. positioned toward the seal.

Install the impeller adjusting shims and impeller (consult the operator's manual for impeller clearance and installation instructions).

**Before starting the pump, reinstall the automatic lubricating grease cup and piping (if removed for seal liner replacement).
Lubricate the seal as indicated below.**

LUBRICATION

Fill the grease cup through the grease fitting with No. 2 lithium base grease until grease escapes from the relief hole. Turn the grease cup arm counterclockwise until it is at the top of the stem: this will release the spring to apply grease to the seal.

NOTE:

Some smoking and leakage may occur after installing a new seal assembly. This should stop after the pump has run a while and the lapped seal faces have seated in.

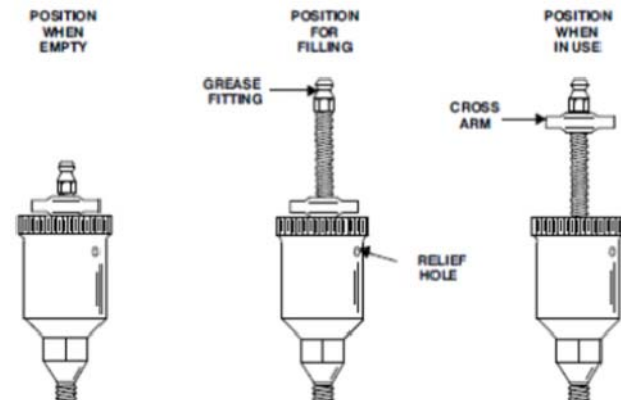

M-500G

Bolt Torque Specifications

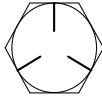

Grade 5

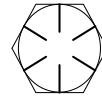

Grade 8

SAE SIZE	Lubricated *		Dry **	
	N.m	ft-lbs	N.m	ft-lbs
1/4	9.5	7	12	9
5/16	20	15	25	18
3/8	35	26	44	33
7/16	55	41	70	52
1/2	85	63	110	80
9/16	125	90	155	115
5/8	170	125	215	160
3/4	300	225	375	280
7/8	490	360	625	450
1	725	540	925	675

Lubricated *		Dry **	
N.m	ft-lbs	N.m	ft-lbs
13.5	10	17	12.5
28	21	35	26
50	36	63	46
80	58	100	75
120	90	150	115
175	130	225	160
215	160	300	225
425	310	550	400
700	500	875	650
1050	750	1300	975

* "Lubricated" means coated with a lubricant such as engine oil, or fasteners with phosphate and oil coatings.

** "Dry" means plain or zinc plated without any lubrication.

Metric size

Thread size x pitch mm	N.m	ft-lbs
M6 X 1.0	10.8 ± 1.0	8.0 ± 0.5
M8 x 1.25	25.5 ± 2.9	19.0 ± 2.0
M10 x 1.5	49.0 ± 4.9	36.0 ± 4.0
M12 x 1.75	88.3 ± 9.8	65.0 ± 7.0
M14 x 1.5	137.0 ± 9.8	101.0 ± 7.0
M16 x 1.5	226.0 ± 9.8	167.0 ± 7.0

Apply 60% torque to bolts that are not listed.

Apply 80% torque when tightened to aluminum alloy.



M-500G

NOTES:

SECTION #VII

OEM Repair Information

GR PUMP INTRODUCTION

Read this manual carefully to learn how to safely install and operate your pump. Failure to do so could result in personal injury or damage to the pump.

This Operation, and Maintenance section is designed to help you achieve the best performance and longest life from your pump.

This pump is an 80 Series, semi-open impeller, self-priming centrifugal model with a suction check valve. The pump is designed for straight-in suction where the medium being pumped enters directly into the impeller eye. It is designed for handling most non-volatile, non-flammable liquids containing specified entrained solids. The basic material of construction for wetted parts is gray iron.

This manual cannot possibly provide detailed instructions and precautions for every aspect of each specific installation by the customer. Therefore, it is the responsibility of the owner/installer of the mixing unit to ensure that applications not addressed in this manual are performed **only** after establishing that neither operator safety nor pump integrity are compromised by the installation. Pumps and related equipment **must** be installed and operated according to all national, local and industry standards.

If there are any questions regarding the pump or its application, which are not covered in this manual or in other literature accompanying this unit, please contact Surface to Surface or your STS distributor.

Surface to Surface Inc 1-800-567-0978

The following are used to alert maintenance personnel to procedures which require special attention, to those which could damage equipment, and to those which could be dangerous to personnel:



Immediate hazards which WILL result in severe personal injury or death. These instructions describe the procedure required and the injury, which will result from failure to follow the procedure.



Hazards or unsafe practices, which COULD result in severe personal injury or death. These instructions describe the procedure required and the injury, which could result from failure to follow the procedure.



Hazards or unsafe practices, which COULD result in minor personal injury or product or property damage. These instructions describe the requirements and the possible damage, which could result from failure to follow the procedure.

NOTE

Instructions to aid in installation, operation, and maintenance, or which clarify a procedure.

SAFETY

This information applies to 80 Series basic pumps. The power source, which is used to drive the pump, may differ from unit to unit. Refer to the manual accompanying the power source before attempting to begin operation.



Make certain that the unit and all piping or hose connections are tight, properly supported and secure before operation.



Before attempting to open or service the pump:

1. Familiarize yourself with this manual.
2. Lock out or disconnect the power source to ensure that the pump will remain inoperative.
3. Allow the pump to completely cool if overheated.
4. Check the temperature before opening any covers, plates, or plugs.
5. Close any suction and discharge valves.
6. Vent the pump slowly and cautiously.
7. Drain the pump.



Do not operate the pump without the shields and/or guards in place over the drive shaft, belts, and/or couplings, or other rotating parts. Exposed rotating parts can catch clothing, fingers, or tools, causing severe injury to personnel.



Do not operate the pump against a closed discharge valve for long periods of time. If operated against a closed discharge valve, pump components will deteriorate, and the liquid could come to a boil, build pressure, and cause the pump casing to rupture or explode.



This pump is designed to handle most non-volatile, non-flammable liquids containing specified entrained solids. Do not attempt to pump liquids for which the pump, driver and/or controls have not been approved, or which may damage the pump or endanger personnel as a result of pump failure.



Use lifting and moving equipment in good repair and with adequate capacity to prevent injuries to personnel or damage to equipment. Suction and discharge hoses and piping must be removed from the pump before lifting.

SAFETY continued



Overheated pumps can cause severe burns and injuries. If overheating of the pump occurs:

1. Stop the pump immediately.
2. Ventilate the area.
3. Allow the pump to completely cool.
4. Check the temperature before opening any covers, plates, gauges, or plugs.
5. Vent the pump slowly and cautiously.
6. Refer to instructions in this manual before restarting the pump.



Do not remove plates, covers, gauges, pipe plugs, or fittings from an overheated pump. Vapor pressure within the pump can cause parts being disengaged to be ejected with great force. Allow the pump to completely cool before servicing.



Never run this pump backwards. Be certain that rotation is correct before fully engaging the pump.



Pumps and related equipment must be installed and operated according to all national, local and industry standards.

OPERATION

Review all SAFETY information in this manual. Follow the instructions on all tags, labels and decals attached to the pump.



This pump is designed to handle most non-volatile, non-flammable liquids containing specified entrained solids. Do not attempt to pump liquids for which the pump, driver and/or controls have not been approved, or which may damage the pump or endanger personnel as a result of pump failure.

PRIMING

Install the unit and hoses as described in this manual.

Make sure that the piping and hose connections are tight, and that the unit is securely mounted. Check that the pump is properly lubricated (see LUBRICATION and REPAIR).

This pump is self-priming, but the pump should never be operated unless there is liquid in the pump casing.



Never operate this pump unless there is liquid in the pump casing. The pump will not prime when dry. Extended operation of a dry pump will destroy the seal assembly.

Add liquid to the pump casing when:

1. The pump is being put into service for the first time.
2. The pump has not been used for a considerable length of time.
3. The liquid in the pump casing has evaporated.

Once the pump casing has been filled, the pump will prime and re-prime as necessary.



After filling the pump casing, reinstall and tighten the fill plug. Do not attempt to operate the pump unless all connecting piping and hoses are securely installed. Otherwise, liquid in the pump forced out under pressure could cause injury to personnel.

To fill the pump, remove the pump casing fill cover or fill plug in the top of the casing, and add clean liquid until the casing is filled. Replace the fill cover or fill plug before operating the pump.

TROUBLESHOOTING

Review all SAFETY information in Section A.



Before attempting to open or service the pump:

1. Familiarize yourself with this manual.
2. Lock out or disconnect the power source to ensure that the pump will remain inoperative.
3. Allow the pump to completely cool if overheated.
4. Check the temperature before opening any covers, plates, or plugs.
5. Close the suction and discharge valves.
6. Vent the pump slowly and cautiously.
7. Drain the pump.

TROUBLE	POSSIBLE CAUSE	PROBABLE REMEDY
<p>PUMP FAILS TO PRIME</p>	<p>Not enough liquid in casing. Suction check valve contaminated or damaged. Air leak in suction line. Leaking or worn seal or pump gasket.</p>	<p>Add liquid to casing. See PRIMING. Clean or replace check valve. Correct leak. Check pump vacuum. Replace leaking or worn seal or gasket.</p>
<p>PUMP STOPS OR FAILS TO DELIVER RATED FLOW OR PRESSURE</p>	<p>Air leak in suction line. Leaking or worn seal or pump gasket. Impeller or other wearing parts worn or damaged. Impeller clogged.</p>	<p>Correct leak. Check pump vacuum. Replace leaking or worn seal or gasket. Replace worn or damaged parts. Check that impeller is properly centered and rotates freely. Free impeller of debris.</p>

PREVENTIVE MAINTENANCE

Pump wear is directly affected by such things as the abrasive qualities, pressure and temperature of the liquid being pumped, this section is intended only to provide general recommendations and practices for preventive maintenance. Regardless of the application however, following a routine preventive maintenance schedule will help assure trouble-free performance and long life from your 80 series pump.

Record keeping is an essential component of a good preventive maintenance program. Changes in suction and discharge gauge readings (if so equipped) between regularly scheduled inspections can indicate problems that can be corrected before system damage or catastrophic failure occurs.

The appearance of wearing parts should also be documented at each inspection for comparison as well. Also, if records indicate that a certain part (such as the seal) fails at approximately the same duty cycle, the part can be checked and replaced before failure occurs, reducing unscheduled down time.

For new applications, a first inspection of wearing parts at 250 hours will give insight into the wear rate for your particular application. Subsequent inspections should be performed at the intervals shown on the chart below. Critical applications should be inspected more frequently.

Preventive Maintenance Schedule					
Item	Service Interval*				
	Daily	Weekly	Monthly	Semi-Annually	Annually
General Condition (Temperature, Unusual Noises or Vibrations, Cracks, Leaks, Loose Hardware, Etc.)	I				
Bearing Lubrication (if so Equipped)	I	I			R
Seal Lubrication (If So Equipped)	I	I			R
Front Impeller Clearance (Wear Plate)				I	
Rear Impeller Clearance (Seal Plate)				I	
Check Valve				I	
Pump and Driver Alignment				I	
Bearings				I	
Bearing Housing				I	
Piping				I	
Driver Lubrication - See Mfgr's Literature				I	

Legend:
I = Inspect, Clean, Adjust, Repair or Replace as Necessary
R = Replace

* Service interval based on an intermittent duty cycle equal to approximately 4000 hours annually
 Adjust schedule as required for lower or higher duty cycles or extreme operating conditions.

GR-83A2 ASSEMBLY PARTS LIST
(P/N #060-GR83A2-KIT)

REF #	DESCRIPTION	STS PART NUMBER	QTY REQ.
1	Grease Cup	060-S36	1
2	1/4" 45° Elbow	018-310-023077	1
3	1/4" NPT x3" Nipple	018-330-006008	1
4	3/8" Nut	060-GRD0615991	15
	3/8" L/W	076-33622	7
5	Seal Plate Assembly	060-GR427A 10010	1
6	Brass Seal Liner	060-GR8314080	1
7	Casing Gasket Set	060-GR229G 18000	1
8	Grease Seal assembly	060-GRGS1000	1
9	Shim Pack	060-GR2X17090	1
10	Impeller	060-GR6950 100105.5	1
11	Wear Plate	060-GR6951 15990	1
12	Pump Casing	060-GR46472-332	1
13	Pipe Plug	060-GR48271-067	1
14	Discharge Elbow	060-54310010	1
15	Discharge Elbow Gasket	060-GR543G 1800	1
16	Stud	060-C0607-15991	10
17	Stud	060-GRC0606-15991	4
18	Pipe Plug	060-GRP1215079	1
19	Hex Cap Screw	060-B061815991	1
	Fiber Washer	060-KF0618040	1
20	Suction Check Valve Assembly	060-GR544A	1
21	HD Machine Screw	060-X040317090	1
	L/W	060-GRJ0417090	1
22	Large Valve Weight	060-136410010	1
23	Check Valve Gasket	060-544G19070	1
24	Small Valve Weight	060-1810010	1
25	Suction Flange	060-294610010	1
26	Pipe Plug	060-P0415079	2

Remote mounted grease cup included in power units

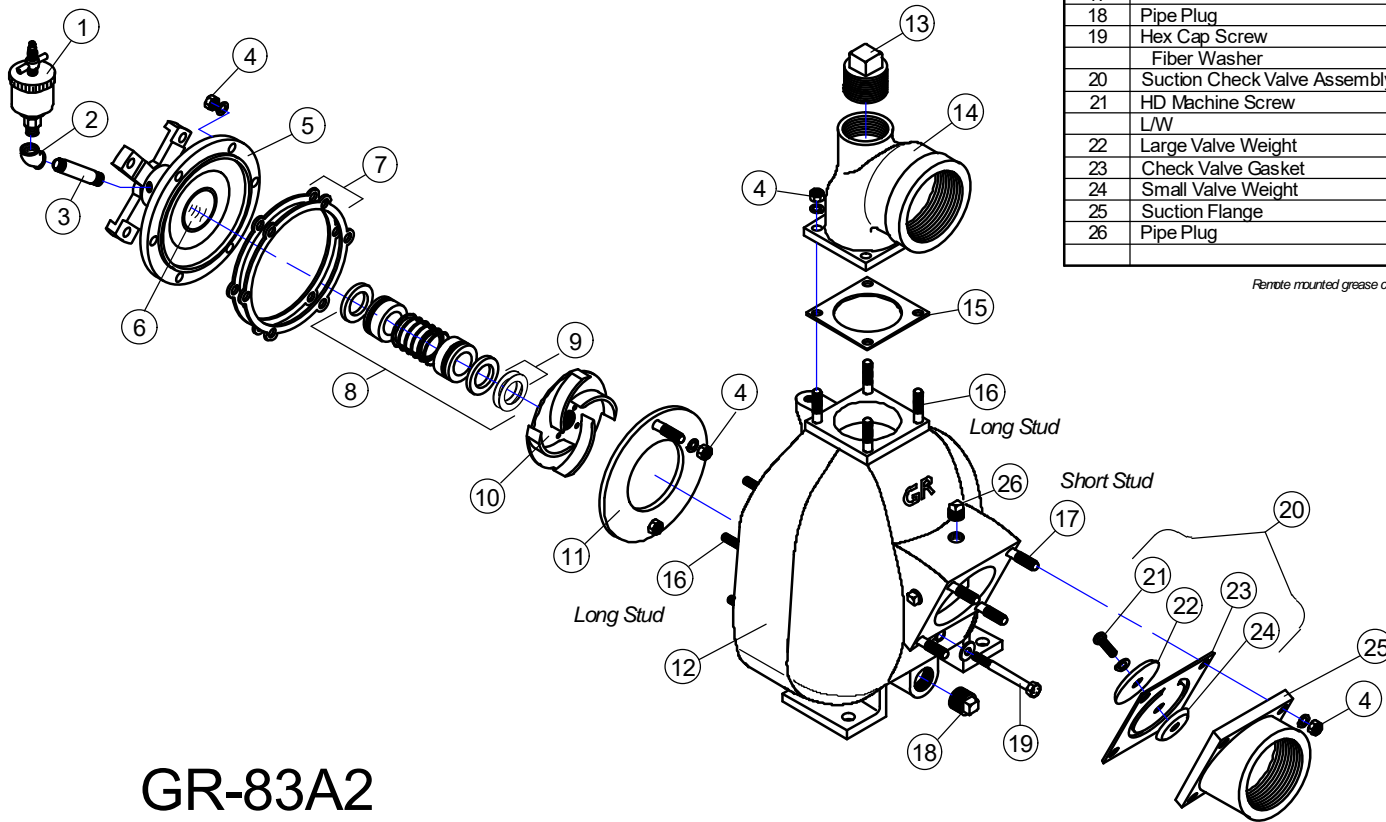

GR-83A2

PUMP AND SEAL DISASSEMBLY AND REASSEMBLY

Review all SAFETY information in Section A.

Follow the instructions on all tags, label and decals attached to the pump.

This pump requires little service due to its rugged, minimum-maintenance design. However, if it becomes necessary to inspect or replace the wearing parts, follow these instructions, which are keyed to the sectional view (see Figure 1) and the accompanying parts list.

This manual will alert personnel to known procedures which require special attention, to those, which could damage equipment, and to those, which could be dangerous to personnel. However, this manual cannot possibly anticipate and provide detailed precautions for every situation that might occur during maintenance of the unit. Therefore, it is the responsibility of the owner/maintenance personnel to ensure that **only** safe, established maintenance procedures are used, and that any procedures not addressed in this manual are performed **only** after establishing that neither personal safety nor pump integrity are compromised by such practices.

Before attempting to service the pump, lock out or disconnect the power source to ensure that it will remain inoperative. Close all valves in the suction and discharge lines.

For power source disassembly and repair, consult the literature supplied with the power source, or contact your local power source representative.



Before attempting to open or service the pump:

1. Familiarize yourself with this manual.
2. Lock out or disconnect the power source to ensure that the pump will remain inoperative.
3. Allow the pump to completely cool if overheated.

4. Check the temperature before opening any covers, plates, or plugs.
5. Close any suction and discharge valves.
6. Vent the pump slowly and cautiously.
7. Drain the pump.



Use lifting and moving equipment in good repair and with adequate capacity to prevent injuries to personnel or damage to equipment. Suction and discharge hoses and piping must be removed from the pump before lifting.

Suction Check Valve Disassembly

Before attempting to service the pump, remove the pump casing drain plug (18) and drain the pump. Clean and reinstall the drain plug.

For access to the check valve, remove the suction hose. Remove the nuts (4) and separate the suction flange (24) and check valve (20) from the pump casing (12).

Inspect the check valve parts for wear or damage. If replacement is required, remove the hardware (21, 22, 23, 24) and separate the check valve gasket and weights.

Pump Casing and Wear Plate Removal

To service the wear plate (11), remove the nuts & lock washers (4), securing the pump casing to the seal plate (5) and engine. Separate the pump casing and remove the gasket set (7).

Inspect the wear plate for scoring or excessive wear.

To remove the wear plate, disengage the hardware (4 & 19). Pull the wear plate out of the pump casing.

PUMP AND SEAL DISASSEMBLY AND REASSEMBLY

Impeller Removal

Before removing the impeller, screw the cross arm on the automatic lubricating grease cup (1) clockwise until it rests against the cover (see Figure 4) to prevent the grease in the cup from escaping. Remove the grease cup and piping (1, 2, & 3).

Using a hardwood block of wood positioned against the impeller vane, strike the hardwood block with a hammer, in a counter clockwise rotation (viewed from the impeller end).

Loosening the impeller is the same rotation as loosening a standard nut and bolt.

Inspect the impeller and replace it if cracked or badly worn. Slide the impeller adjusting shims (9) off the impeller shaft. Tie and tag the shims, or measure and record their thickness for ease of reassembly.

Seal Removal and Disassembly

Remove the outer rotating element, shaft sleeve, and remaining seal parts off the shaft as a unit. Carefully remove the stationary and rotating seal elements, packing rings and washers, seal spring and spacer sleeve from the seal plate.

Inspect the seal plate and replace it if cracked or badly worn. To remove the seal plate (5) from the engine, remove the bolts and lock washers, or nuts and lock washers from the studs. Inspect the seal liner (6) for wear or grooves that could cause leakage or damage to the seal packing rings. The seal liner is a press fit into the seal plate and does not normally require replacement.

If the seal liner requires replacement, remove the seal plate assembly as described above, and position it on the bed of an arbor (or hydraulic) press. Use a new sleeve to force the old one out. After the new liner is properly installed, a 3/8-inch (9.5mm) diameter hole must be drilled through it to permit the flow of lubricant to the seal assembly. Be careful to center the drill in the threaded grease piping hole and not damage the threads. Deburr the hole from the inside of the seal liner after drilling.

Seal Reassembly and Installation

(Figures 1 and 3)

Clean the seal cavity and shaft with a cloth soaked in fresh cleaning solvent.



WARNING!

Most cleaning solvents are toxic and flammable. Use them only in a well ventilated area free from excessive heat, sparks, and flame. Read and follow all precautions printed on solvent containers.

The seal is not normally reused because wear patterns on the finished faces cannot be realigned during reassembly. This could result in premature failure. If necessary to reuse an old seal in an emergency, carefully wash all metallic parts in fresh cleaning solvent and allow to dry thoroughly.

Handle the seal parts with extreme care to prevent damage. Be careful not to contaminate precision finished faces; even fingerprints on the faces can shorten seal life. If necessary, clean the faces with a non-oil based solvent and a clean, lint-free tissue. Wipe lightly in a concentric pattern to avoid scratching the faces.

Inspect the seal components for wear, scoring, grooves, and other damage that might cause leakage.

Clean and polish the shaft sleeve, or replace it if there are nicks or cuts on either end. If any components are worn, replace the complete seal.

Never mix old and new seal parts.

If a replacement seal is being used, remove it from the container and inspect the precision finished faces to ensure that they are free of any foreign matter.

To ease installation of the seal, lubricate the seal liner (6) with water or a very small amount of oil, and apply a drop of light lubricating oil on the finished faces. Assemble the seal as follows, (see Figure 3).

Slide the seal plate assembly over the impeller shaft and secure the seal plate to the engine using the bolts and lock washers or nuts and lock washers on studs.

Slide the inboard rotating element into the lubricated seal liner with the chamfered side toward the shaft shoulder.

PUMP AND SEAL DISASSEMBLY AND REASSEMBLY

Seal Reassembly and Installation *continued* (Figures 1 and 3)

Sub assemble the inboard stationary seat, packing ring and stationary washer. Press this unit into the lubricated seal liner until the seal faces contact.

A push tube cut from a length of plastic pipe or deep socket would aid in this installation. The I.D. of the tube or socket should be approximately the same size as the I.D. of the seal spring.

Slide the spacer sleeve onto the shaft until it seats against the inboard rotating element and install the seal spring.

Sub assemble the outboard stationary seat, packing ring and stationary washer. Press this unit into the lubricated seal liner. Install the outboard rotating element with the chamfered side toward the impeller. Lubricate the seal assembly as indicated in LUBRICATION *after the impeller has been installed.*

Impeller Installation

Inspect the impeller and replace it if cracked or badly worn.



The shaft and impeller threads must be completely clean before reinstalling the impeller. Even the slightest amount of dirt on the threads can cause the impeller to seize to the shaft, making future removal difficult or impossible without damage to the impeller or shaft.

Install the same thickness of impeller shims (9) as previously removed and screw the impeller onto the shaft until tight. Bump the impeller tight with a wood block or soft mallet.

The clearance between the back of the impeller and the seal plate should be between 0.010 and 0.020 inch (0,25 to 0,51 mm).

Measure this clearance and add or remove shims from the impeller adjusting shim set until the correct clearance is achieved.

Pump Casing and Wear Plate Installation

If the wear plate assembly (11) was removed, install the new wear plate in the pump casing and secure it with the hardware (4 & 19).

Install a new set of casing gaskets (7) and slide the pump casing over the impeller and against the gaskets.

The clearance between the face of the impeller and the wear plate should be between .010 and .020 inch (0,25 to 0,51 mm).

Remove gaskets from the gasket set until the correct clearance is achieved. Secure the pump casing to the seal plate with nuts & lock washers (4).

Suction Check Valve Installation

Inspect the check valve components and replace them as required. Sub assemble the check valve weights and gasket using the attaching hardware (21, 22, 23, 24).

Install the check valve assembly (20) on to the studs (17).

Replace the suction flange onto the studs (17), and secure with the nuts (4).

Check the operation of the check valve to ensure proper seating and free movement.

Final Pump Reassembly

Be sure all hardware and drain plugs are tight, and that the pump is secure to the base and power source.

Install the suction and discharge lines / hoses and open all valves. Make certain that all piping connections are tight, and that the weight of the hose is independently supported and secure.

Before starting the pump, fill the pump casing with clean liquid.

Apply Pipe Sealant or equivalent compound to the fill plug (13). Reinstall and tighten the fill plug.

Refer back to OPERATION, before putting the pump back into service.

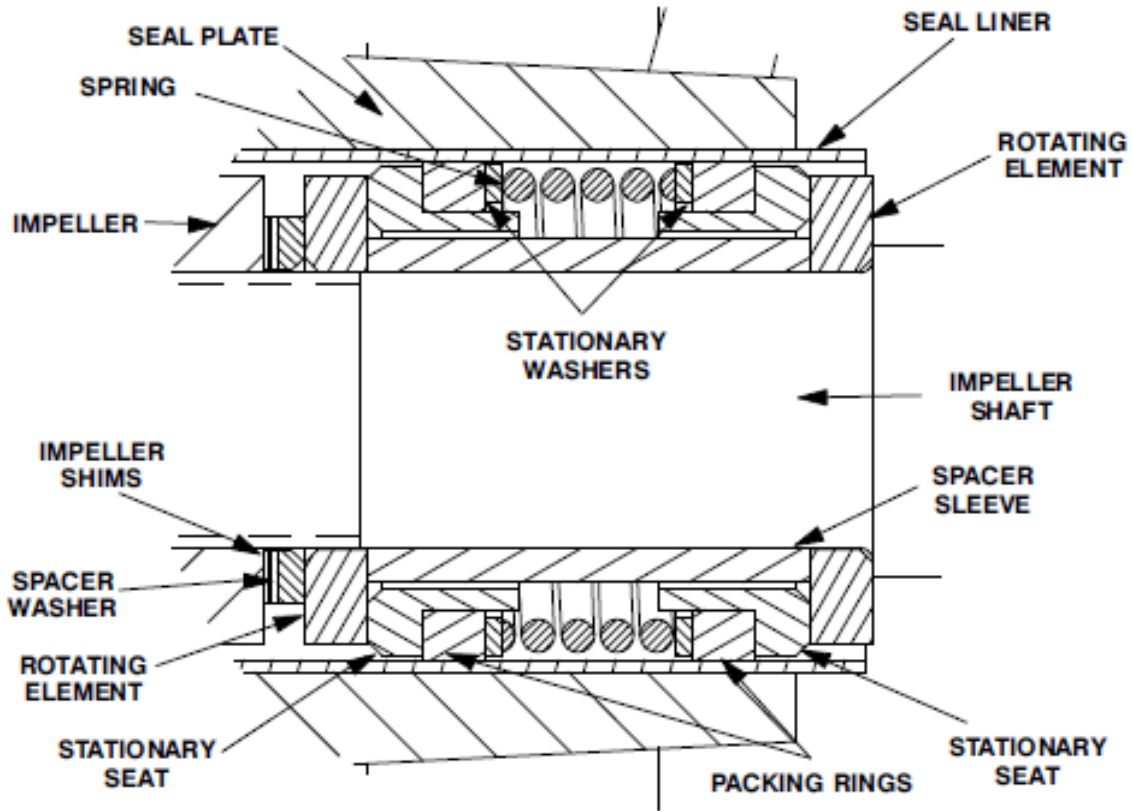

Figure 3. Seal Assembly

LUBRICATION

Fill the grease cup (11) through the grease fitting with No. 2 lithium base grease until grease escapes from the relief hole. Turn the grease cup arm counterclockwise until it is at the top of the stem; this will release the spring to apply grease to the seal (see Figure 4).

NOTE:

Some smoking and leakage may occur after installing a new seal assembly. This should stop after the pump has run a while and the lapped seal faces have seated in

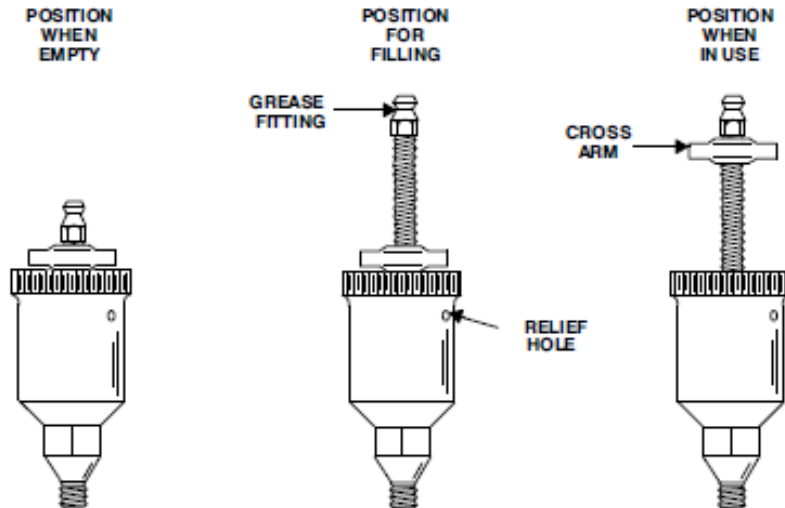

Figure 4. Automatic Lubricating Grease Cup

Grease Seal Installation Instructions Centrifugal Pump Application

When replacing the sea, never mix old and new parts. Wear patterns on the old seal faces cannot be realigned during reassembly, and use of old parts can result in premature failure of the new seal.

Before installing the seal, inspect the bore of the seal liner for excessive wear or grooves that might cause leakage or damage to the seal packing rings. If the seal liner must be replaced, use the new seal liner and arbor (or hydraulic) press to force the old one out. After the liner is installed, drill a 3/8" diameter hole through it to permit the flow of lubricant to the seal liner. Be Careful to center the drill in the threaded lubrication hole so not to damage the threads. Deburr the hole from the inside of the seal liner after drilling.

Clean the seal cavity and shaft with a cloth soaked in fresh cleaning solvent. Be sure to follow all safety precautions described on the solvent container.

Remove the new seal and inspect the precision finished faces to ensure that they are free of any foreign matter. To ease installation of the seal, lubricate the packing rings, spacer sleeve, and seal liner with water or a very small amount of oil and apply a drop of light lubrication oil on the precision finished faces. Refer to the illustration, and assemble the seal as follows.

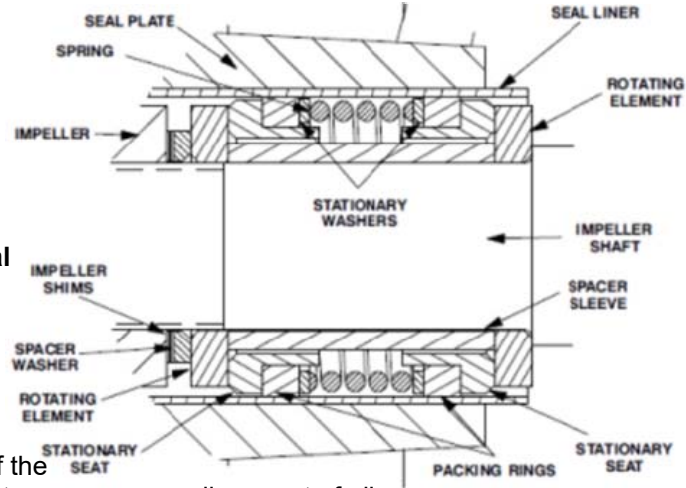

Installation of the inboard rotating element is dictated by the configuration of the shaft shoulder. If there is a radius at the shaft shoulder, the larger chamfer on the I.D. of the inboard rotating element must be positioned toward the shaft shoulder. If there is an undercut at the shaft shoulder, the larger chamfer must be positioned away from the shaft shoulder. Determine the correct position for the rotating element and slide it onto the shaft.

Sub assemble the inboard stationary element, packing ring and spring washer, and press this subassembly into the lubricated seal liner. A push tube cut from a length of plastic pipe or a properly sized deep socket will aid seal installation. The O.D. of the tube should be about the same size as the O.D. of the seal spring.

Install the spacer sleeve and spring.

Sub assemble the outboard stationary element, packing ring and spring washer. Press this subassembly into the lubricated seal liner. If the outboard rotating element has a chamfered side, install it with the chamfer facing the impeller end of the shaft.

If your pump requires a spacer washer, install the spacer washer with the chamfer on the I.D. positioned toward the seal.

Install the impeller adjusting shims and impeller (consult the operator's manual for impeller clearance and installation instructions).

**Before starting the pump, reinstall the automatic lubricating grease cup and piping (if removed for seal liner replacement).
Lubricate the seal as indicated below.**

LUBRICATION

Fill the grease cup through the grease fitting with No. 2 lithium base grease until grease escapes from the relief hole. Turn the grease cup arm counterclockwise until it is at the top of the stem; this will release the spring to apply grease to the seal.

NOTE:

Some smoking and leakage may occur after installing a new seal assembly. This should stop after the pump has run a while and the lapped seal faces have seated in.

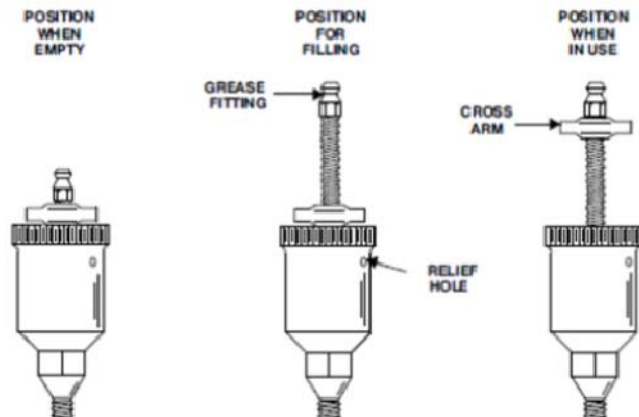

FOR ENGINE SERVICE GO TO:

www.briggsandstratton.com



Pick which service you require on the bottom
And follow prompts to find what you are looking for.

Surface to Surface has a limited engine parts inventory. Parts not in stock will have to be ordered.

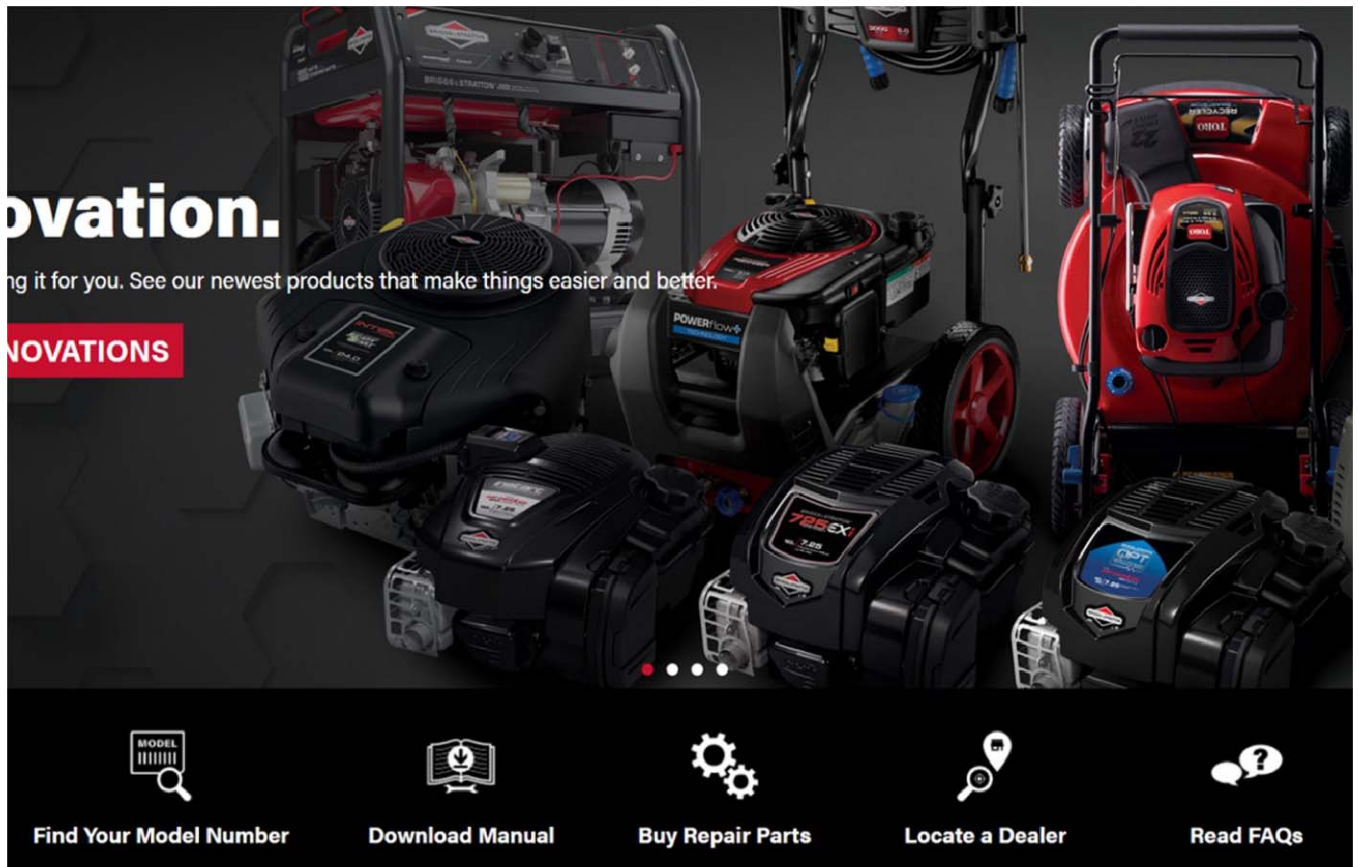

<https://www.briggsandstratton.com>

COUPLING INSTALLATION & ASSEMBLY

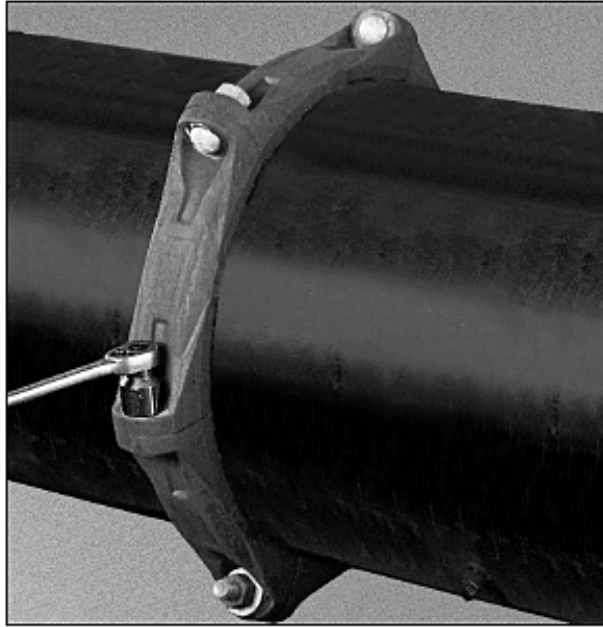

The instructions are based on pipe grooved in accordance with GUVLOK® grooving specifications. Check pipe ends for proper groove dimensions and to assure that the pipe ends are free of indentations and projections which would prevent proper sealing.

ALWAYS USE A GRUVLOK® LUBRICANT FOR PROPER COUPLING ASSEMBLY. Thorough lubrication of the external surface of the gasket is essential to prevent pinching and possible damage to the gasket. For temperatures above 150° F (65.6° C) use GUVLOK Xtreme™ Lubricant and lubricate all gasket surfaces, internal and external. See GUVLOK Lubricants in the Technical Data section of the GUVLOK catalog for additional important information.

SPECIFIED BOLT TORQUE

Specified bolt torque is for the oval neck track bolts used on GUVLOK® couplings and flanges. The nuts must be tightened alternately and evenly until fully tightened. Caution: Use of an impact wrench is not recommended because the torque output can vary significantly due to many variables including air pressure supply, battery strength and operational variations.

CAUTION: Proper torquing of coupling bolts is required to obtain specified performance. Over torquing the bolts may result in damage to the bolt and/or casting which could result in pipe joint separation. Under torquing the bolts may result in lower pressure retention capabilities, lower bend load capabilities, joint leakage and pipe joint separation. Pipe joint separation may result in significant property damage and serious injury.

ANSI SPECIFIED BOLT TORQUE		
Bolt Size	Wrench Size	Specified Bolt Torque *
In.	In.	Ft.-Lbs
3/8	11/16	30-45
1/2	3/4	80-100
5/8	1 1/16	100-130
3/4	1 1/4	130-180
7/8	1 3/8	180-220
1	1 5/8	200-250
1 1/8	1 7/8	225-275
1 1/4	2	250-300

* Non-lubricated bolt torques.

METRIC SPECIFIED BOLT TORQUE		
Bolt Size	Wrench Size	Specified Bolt Torque *
mm	mm	N-m
M10	16	40-60
M12	22	110-150
M16	24	135-175
M20	30	175-245
M22	34	245-300
M24	36	270-340

* Non-lubricated bolt torques.

NOTE: Specified torques are to be used unless otherwise noted on Product Installation Instructions.

FIG. 7000

Lightweight Flexible Coupling



1 CHECK & LUBRICATE GASKET— Check gasket to be sure it is compatible for the intended service. Apply a thin coating of Gruvlok lubricant to outside and sealing lips of the gasket. Be careful that foreign particles do not adhere to lubricated surfaces.



2 GASKET INSTALLATION— Slip the gasket over the pipe end, making sure the gasket lip does not overhang the pipe end.



3 ALIGNMENT— After aligning the two pipe ends together, pull the gasket into position, centering it between the grooves on each pipe. Gasket should not extend into the groove on either pipe.

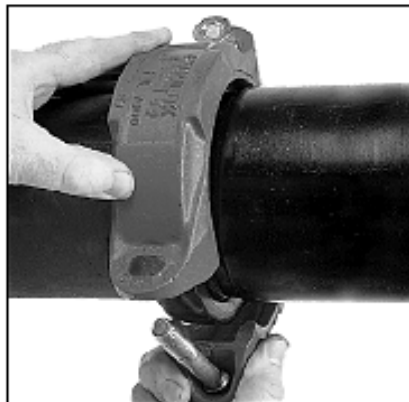

4 HOUSINGS— With one nut unthreaded to the end of the bolt, unthread the other nut completely and swing the coupling housing halves over the gasket, making sure the housing keys engage the grooves. Insert the bolt and turn the nuts finger tight.

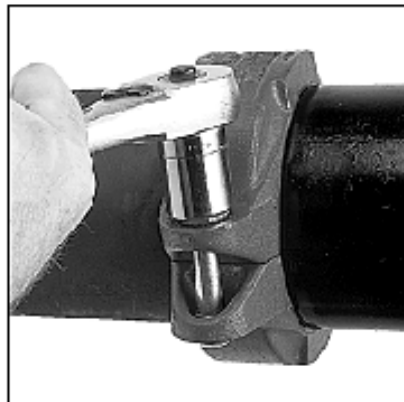

5 TIGHTEN NUTS— Tighten the nuts alternately and equally to the specified bolt torque. The housing bolt pads must make metal-to-metal contact.

CAUTION: Uneven tightening may cause the gasket to pinch.

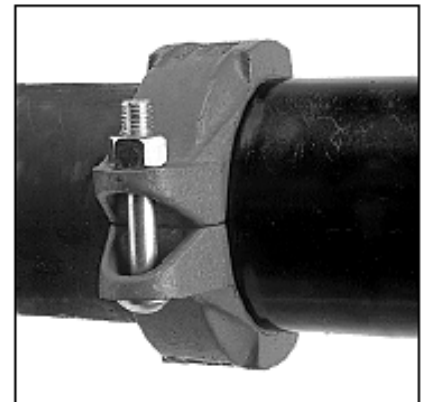

6 ASSEMBLY IS COMPLETE— Visually inspect the pipe joint to assure the coupling keys are fully engaged in the pipe grooves and the bolt pads are in firm even metal-to-metal contact on both sides of the coupling.

CAUTION: Use of an impact wrench is not recommended because the torque output can vary significantly due to many variables including air pressure supply, battery strength and operational variations.

CAUTION: Proper torquing of coupling bolts is required to obtain specified performance. Over torquing the bolt may result in damage to the bolt and/or casting which could result in pipe joint separation. Under torquing the bolts may result in lower pressure retention capabilities, lower bend load capabilities, joint leakage and pipe joint separation. Pipe joint separation may result in significant property damage and serious injury.

NOTE: VdS - Roll Grooving Approval Specifications, see the Technical Data/Installation Instructions section on Anvil's web site - www.anvilintl.com

FIG. 7003

Hingelok™ Coupling

NOTE: Remove locking pin from handle before opening coupling.



1 CHECK & LUBRICATE GASKET— Check gasket to be sure it's compatible for the intended service. Apply a thin coating of GUVLOK lubricant to outside and sealing lips of the gasket. Be careful that foreign particles do not adhere to lubricated surfaces.



2 GASKET INSTALLATION— Slip the gasket over the pipe end making sure the gasket lip does not overhang the pipe end.



3 ALIGNMENT— After aligning the two pipe ends, pull the gasket into position centering it between the grooves on each pipe. Gasket should not extend into the groove on either pipe.



4 HOUSINGS— Put one half of the open coupling over the gasket as the coupling keys fit firmly into the grooves on each pipe end. Swing the other half of the coupling into position around the gasket and into the grooves.

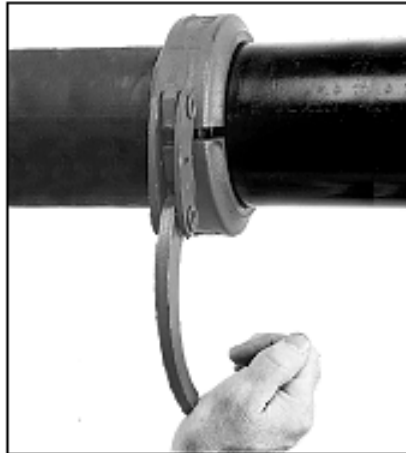

5 LOCK COUPLING— Fit the nose of the locking handle in the notch of the opposite housing. Press firmly down on the handle until it makes contact with the coupling housing. Insert locking pin into handle linkage to secure handle in closed position. (See Caution.)



6 ASSEMBLY IS COMPLETE— Visually inspect the pipe joint to assure the coupling keys are fully engaged in the pipe grooves and the bolt pads are in firm even metal-to-metal contact on both sides of the coupling.

CAUTION:

- 1) Hammering or banging on the handle or coupling housing could cause serious damage to the locking device and coupling assembly. The result may be an unsuitable pipe joint and unusable coupling assembly.
- 2) Care needs to be taken so that fingers do not get caught or pinched when handle is placed in locked position as a result of cam action of handle assembly.
- 3) When re-using coupling and gasket, always inspect gasket for damage and hinge/handle assembly for looseness, distortion or any other damage.

SECTION #VIII

(Parts Manual)

PU-G3 ASSEMBLY PARTS LIST

(#PU-G3)

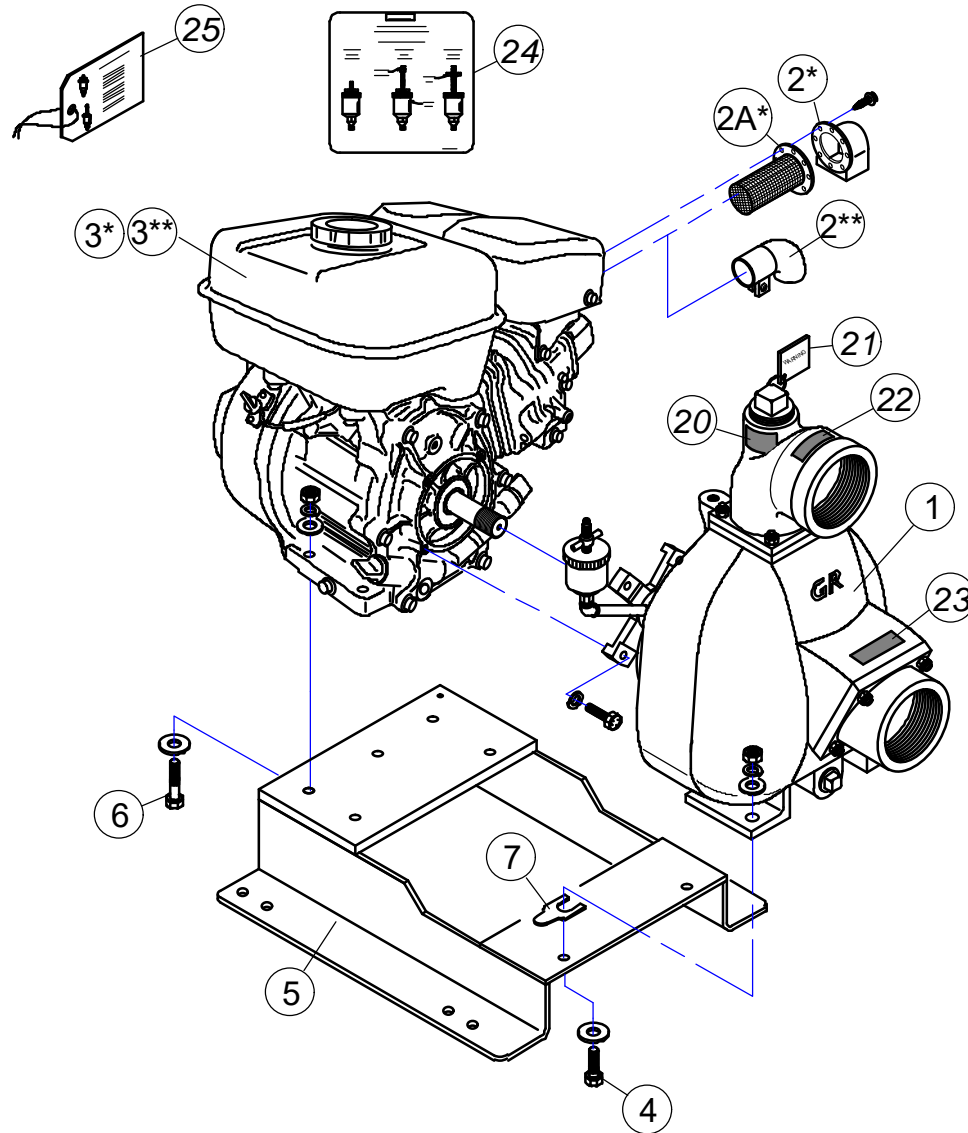

REF #	DESCRIPTION	STS P/N	QTY REQ.
1	Gorman-Rupp 3" Pump	060-GR83A2-KIT	1
2*	Exhaust Deflector	033-796-956	1
2A*	Exhaust Spark Arrestor	033-796-399	1
2**	Exhaust Deflector	033-697816	1
3*	B&S Vanguard Gasoline Engine	033-19L232-0120-F1	1
3**	B&S Intek Gasoline Engine	033-20T232-0125-F1	1
4	3/8" x 1 1/4" Bolt	076-13107	2
	3/8" F/W	076-33008	4
	3/8" L/W	076-33622	2
	3/8" Nut	076-36306	2
5	Engine / Pump Mount Base	JR-3022-V2	1
6	5/16" x 2" Bolt	076-13061	4
	5/16" F/W	076-33006	4
	5/16" L/W	076-33620	4
	5/16" Nut	076-36304	4
7	Motor Shim S/S	034-QA SHIM PACK	2
8	3/8" x 1 1/2" Bolt & L/W	included with pump kit #1	4
20	"PRIME" Decal	060-GR6588AH	1
21	Pressure Warning Tag	060-GR6588BG	1
21A	Security Wire	090-CIPG-SA948	1
22	"DISCHARGE" Decal	060-GR6588BJ	1
23	"SUCTION" Decal	060-GR6588AG	1
24	"Grease Cup Instructions" Decal	060-GR6588BD	1
25	"Grease Cup Instructions" Tag	060-GR38816-301	1
	10w30 engine motor oil	074-1030DURON	1.6L

*B&S Vanguard Gasoline Engine
 **B&S Intek Gasoline Engine

Surface to Surface Inc.®

DWR. NUM. PU-G3	DATE. 08 / 05 / 22
	REV. 09 / 21 / 23

GR-83A2 ASSEMBLY PARTS LIST

(P/N #060-GR83A2-KIT)

REF #	DESCRIPTION	STS PART NUMBER	QTY REQ.
1	Grease Cup	060-S36	1
2	1/4" 45° Elbow	018-310-023077	1
3	1/4" NPT x3" Nipple	018-330-006008	1
4	3/8" Nut	060-GRD0615991	15
	3/8" L/W	076-33622	7
5	Seal Plate Assembly	060-GR427A 10010	1
6	Brass Seal Liner	060-GR8314080	1
7	Casing Gasket Set	060-GR229G 18000	1
8	Grease Seal assembly	060-GRGS 1000	1
9	Shim Pack <i>Included with Seal kit #8</i>	060-GR2X17090	1
10**	Impeller (60 Hz.)	060-GR6950 100105.5	1
	Impeller (50 Hz.)	060-GR6950 10010	1
11	Wear Plate	060-GR6951 15990	1
12	Pump Casing <i>c/w studs&plugs</i>	060-GR46472-332	1
13	Pipe Plug	060-GR48271-067	1
14	Discharge Elbow	060-54310010	1
15	Discharge Elbow Gasket	060-GR543G 1800	1
16	3/8" NC Stud	060-C0607-15991	10
17	3/8" NC Stud	060-GRC0606-15991	4
18	Pipe Plug	060-GRP1215079	1
19	Hex Cap Screw	060-B061815991	1
	Fiber Washer	060-GRKF06 18040	1
20	Suction Check Valve Assembly	060-GR544A	1
21	HD Machine Screw	060-GRX040317090	1
	L/W	060-GRJ0417090	1
22	Large Valve Weight	060-136410010	1
23	Check Valve Gasket	060-GR544G19070	1
24	Small Valve Weight	060-1810010	1
25	Suction Flange	060-294610010	1
26	Pipe Plug	060-GRP04 15079	2
30	"Pressure Warning" Tag	060-GR6588BG	1
31	"PRIME" Decal	060-GR6588AH	1
32	"DISCHARGE" Decal	060-GR6588BJ	1
33	"SUCTION" Decal	060-GR6588AG	1
34	"Grease Cup Instructions" Decal	060-GR6588BD	1
35	"Grease Cup Instructions" Tag	060-GR38816-301	1

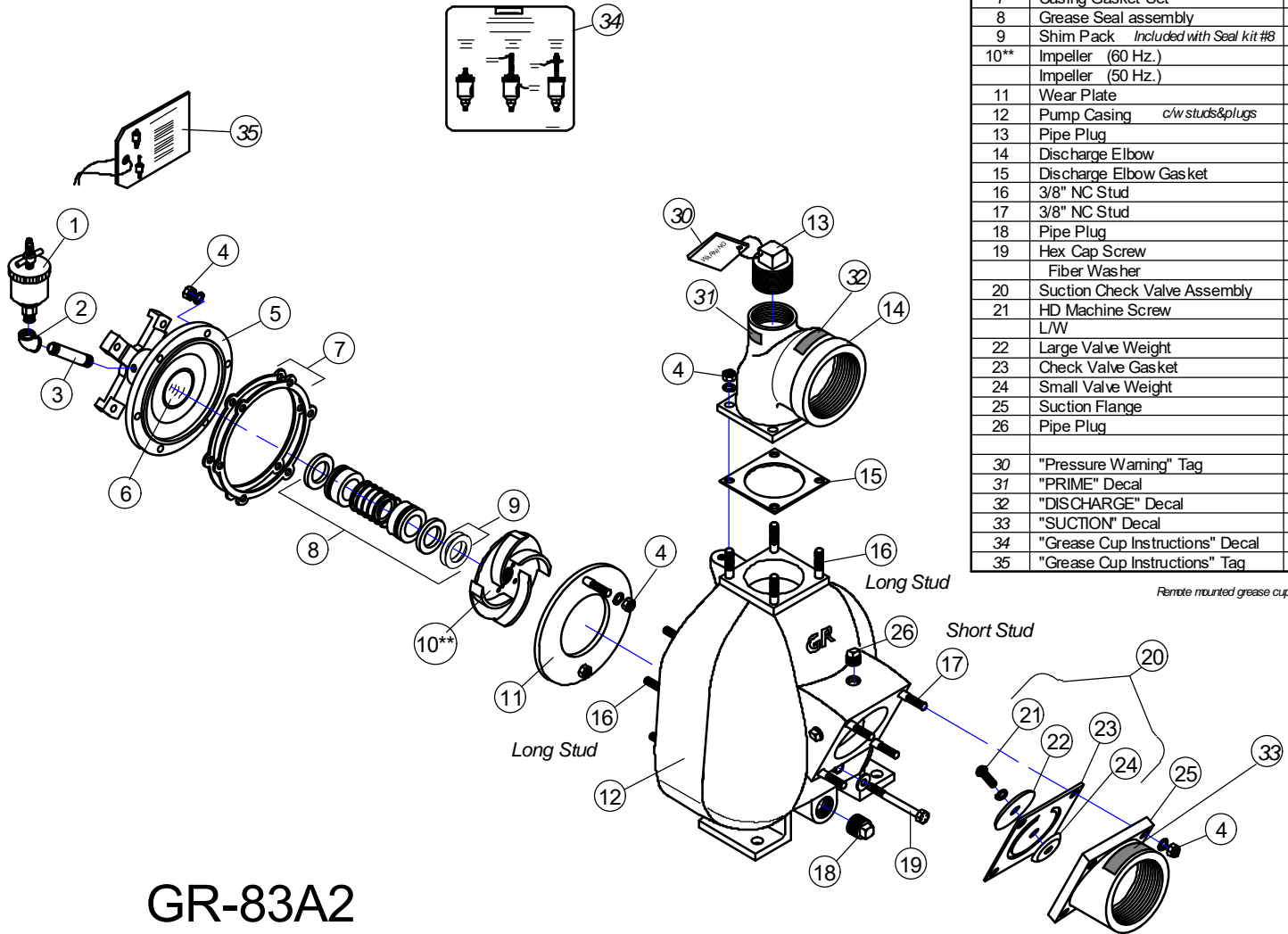

Remote mounted grease cup included in power units

GR-83A2

BU-500 ASSEMBLY PARTS LIST
(P/N #BU-500)

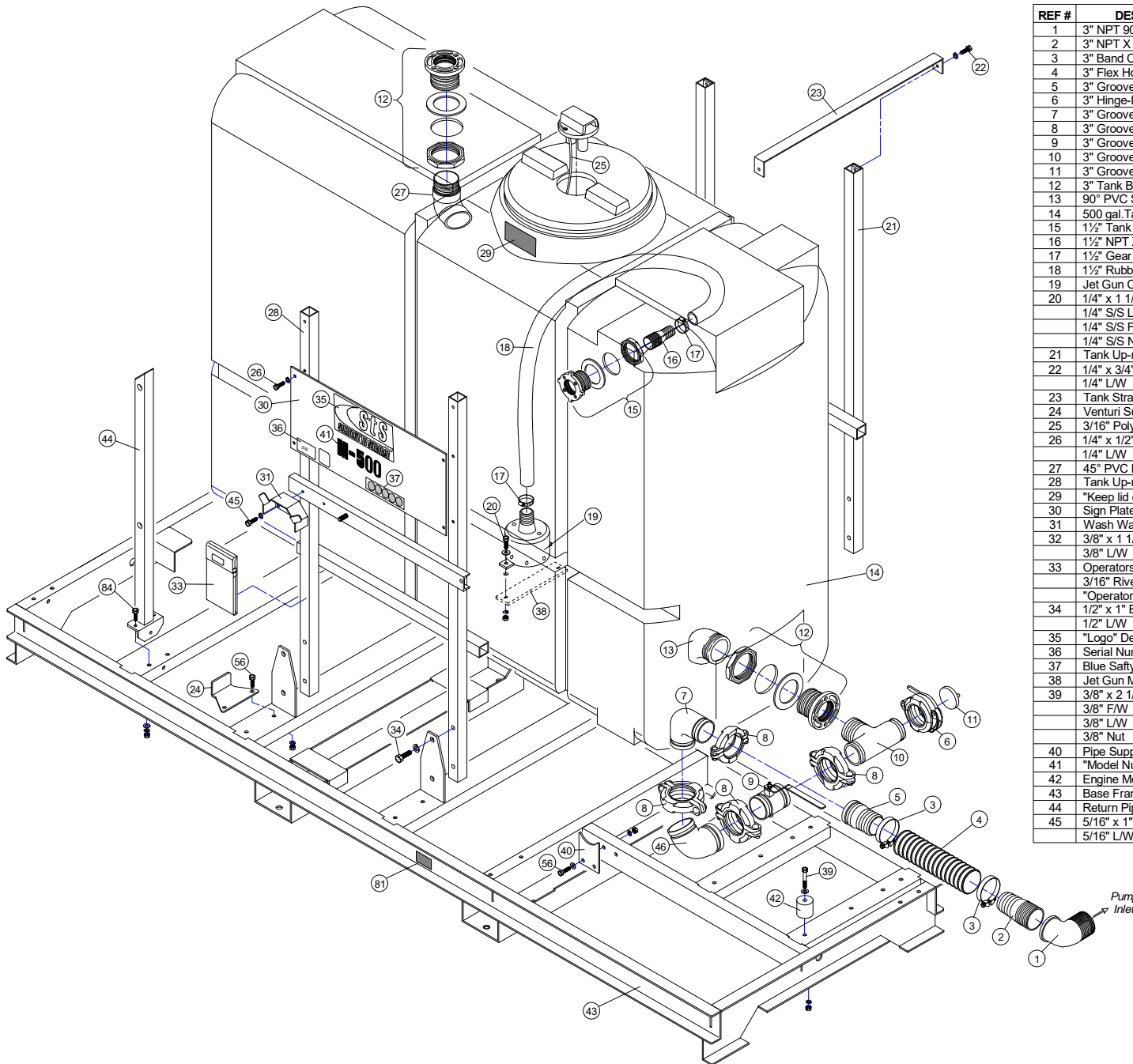

REF #	DESCRIPTION	STS PART NUMBER	QTY REQ.	
1	3" NPT 90° Street Elbow	018-310-01760-3	2	B
2	3" NPT X Hose Barb	018-1661268258	3	B
3	3" Band Clamp	025-MIK-85-91	6	
4	3" Flex Hose	JR-3019-C	1	
5	3" Groove x Hose Barb	020-1661-268282	2	B
6	3" Hinge-Loc Coupler	020-390-20006-1	2	B
7	3" Grooved 90° Elbow	020-390-01426-4	2	B
8	3" Groove-Loc Coupler	020-390-00030-5	9	B
9	3" Grooved Butterfly Valve	023-7005-01139	2	
10	3" Grooved x NPT Suction Tee	JR-3025	1	B
11	3" Grooved End Cap	020-390-03018-7	1	B
12	3" Tank Bung	086-3" TANK BUNG	2	
13	90° PVC Suction Elbow	JR-3021-B	1	
14	500 gal. Tank	JR-5020	1	
15	1½" Tank Bung	086-1.5 BUNG	1	
16	1½" NPT X Hose Barb	018-1661268233	3	B
17	1½" Gear Clamp	025-HS 28	4	
18	1½" Rubber Hose	JR-3019-B	1	
19	Jet Gun Casting	SR-75048	1	B
20	1/4" x 1 1/2" S/S Bolt	076-70009	2	
	1/4" S/S L/W	076-0173192	2	
	1/4" S/S F/W	076-11545141	2	
	1/4" S/S Nut	076-70710	2	
21	Tank Up-rite (back side)	JR-3013-V2	1	O
22	1/4" x 3/4" Bolt	076-13003	4	
	1/4" L/W	076-33618	4	
23	Tank Straps	JR-3017-V2	2	O
24	Venturi Support	JR-3007-B	1	O
25	3/16" Poly Nylon Rope	084-3/16 ROPE	24"	
26	1/4" x 1/2" Bolt	076-13001	4	
	1/4" L/W	076-33618	4	
27	45° PVC Return Elbow	JR-3021-A	1	
28	Tank Up-rite (hopper side)	JR-3012-V2	1	O
29	"Keep lid closed" Decal	070-STS-30-B	1	
30	Sign Plate	JR-3047-V2	1	W
31	Wash Wand Holder	SR-75017	1	O
32	3/8" x 1 1/4" Bolt	076-13107	2	
	3/8" L/W	076-33622	2	
33	Operators Manual Holder	084-9000-07	1	
	3/16" Rivet	076-41228	2	
	"Operators Manual" Decal	070-STS-036	1	
34	1/2" x 1" Bolt	076-13205	8	
	1/2" L/W	076-33626	8	
35	"Logo" Decal	070-STS-026W	1	
36	Serial Number Plate	071-STS-001-BNK	1	
37	Blue Safty Decal	070-STS-038	1	
38	Jet Gun Mounting Bar	SR-75049	1	B
39	3/8" x 2 1/2" Bolt	076-13113	4	
	3/8" F/W	076-33008	4	
	3/8" L/W	076-33622	4	
	3/8" Nut	076-36306	4	
40	Pipe Support	SR-75001-J	1	B
41	"Model Number" Decal	070-STS-028-E	1	
42	Engine Mount Spacers	SR-75016	4	B
43	Base Frame	JR-5010	1	O
44	Return Pipe Post	JR-309	1	O
45	5/16" x 1" Bolt	076-13055	2	
	5/16" L/W	076-33620	2	

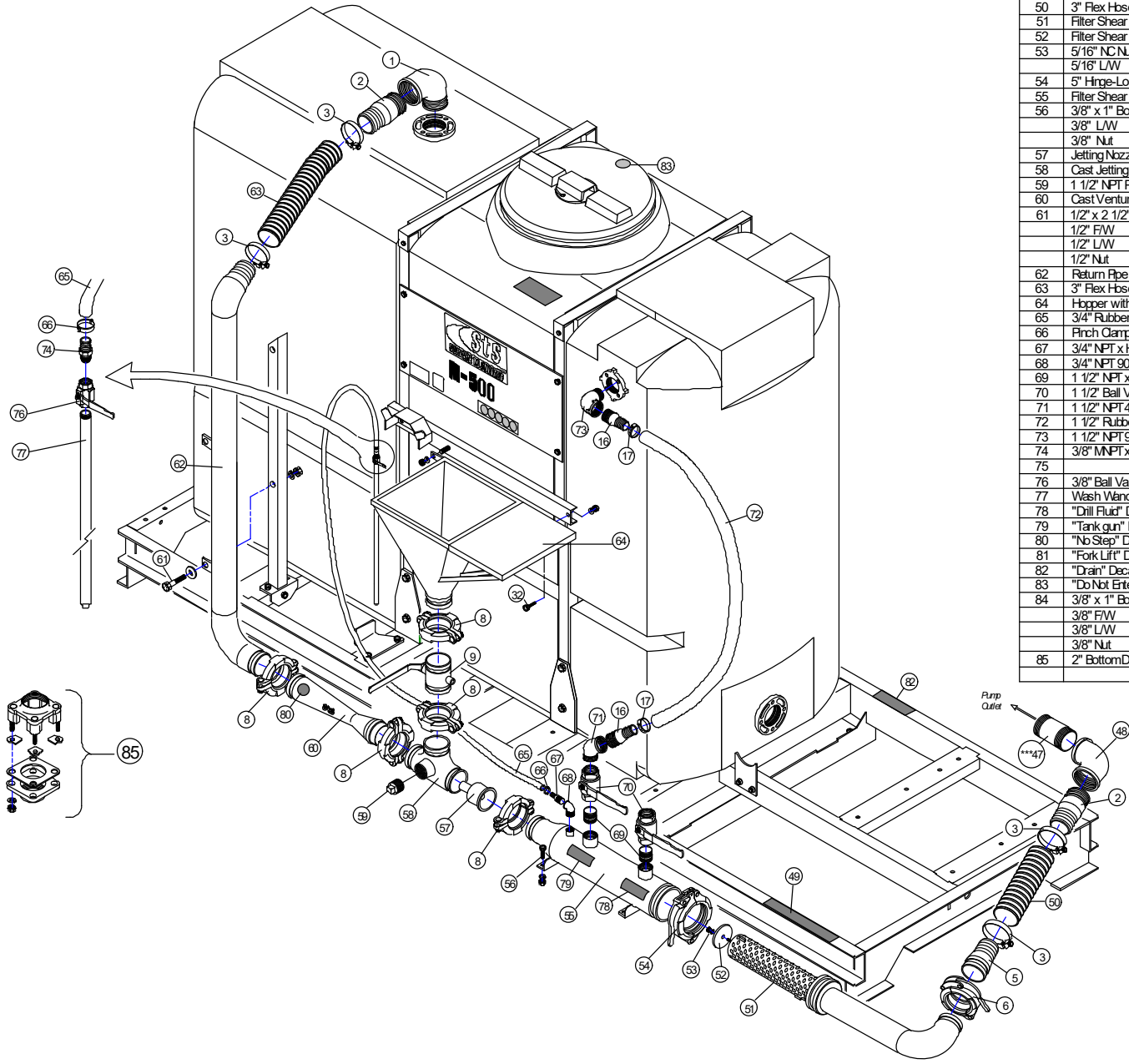

46	3" Grooved 45° Elbow	020-390-01482-7	1	B
***47	3" NPT x 3 1/2" Nipple (Gas, Hyd.)	018-330-04560-4	1	B
	3" NPT x 4" Nipple (Diesel)	018-330-0452010	1	B
48	3" NPT 90° Elbow	018-310-00220-9	1	B
49	"Clean Filter" Decal	070-ST5-027-A	1	
50	3" Flex Hose	JR-3019-F	1	
51	Filter Shear Carriage	JR-3026	1	O
52	Filter Shear Carriage End Cap	JR-3028-3	1	O
53	5/16" NC Nut	076-36304	1	
	5/16" LW	076-33620	1	
54	5" Hinge-Loc Coupler	020-390-20012-9	1	B
55	Filter Shear Housing	JR-3030	1	O
56	3/8" x 1" Bolt	076-13105	8	
	3/8" LW	076-33622	8	
	3/8" Nut	076-36306	8	
57	Jetting Nozzel	JR-3032-NE	1	O
58	Cast Jetting Tee	JR-3039	1	O
59	1 1/2" NPT Pipe Plug	018-318-90252-5	1	O
60	Cast Venturi Tube	JR-3038	1	O
61	1/2" x 2 1/2" Bolt	076-13213	2	
	1/2" FW	076-33012	2	
	1/2" LW	076-33626	2	
	1/2" Nut	076-36310	2	
62	Return Pipe	JR-3040-V2	1	O
63	3" Flex Hose	JR-3019-E	1	
64	Hopper with Table	JR-3033	1	O
65	3/4" Rubber Hose	SR-75074-H	1	
66	Pinch Clamp	025-2731	2	
67	3/4" NPT x Hose Barb	018-1661268225	1	B
68	3/4" NPT 90° Street Elbow	018-310-01640-7	1	B
69	1 1/2" NPT x Close Nipple	018-330-03260-8	2	B
70	1 1/2" Ball Valve	022-423-00012-4	2	
71	1 1/2" NPT 45° Street Elbow	018-310-02800-6	1	B
72	1 1/2" Rubber Hose	JR-3019-A	1	
73	1 1/2" NPT 90° Street Elbow	018-310-01700-9	1	B
74	3/8" MNPT x 3/4" Hose Barb	018-125-12C	1	
75				
76	3/8" Ball Valve	022-423-00002-5	1	
77	Wash Wand	SR-75047	1	R
78	"Drill Fluid" Decal	070-ST5-027-D	1	
79	"Tank gun" Decal	070-ST5-027-B	1	
80	"No Step" Decal	070-15080-B	1	
81	"Fork Lift" Decal	070-16072-B	2	
82	"Drain" Decal	070-ST5-027-C	1	
83	"Do Not Enter" Decal	070-16051-B	1	
84	3/8" x 1" Bolt	076-13105	3	
	3/8" FW	076-33008	3	
	3/8" LW	076-33622	3	
	3/8" Nut	076-36306	3	
85	2" Bottom Drain Bung	086-BF220BD	1	

Paint Color

- B = Black
- O = Orange
- W = White