

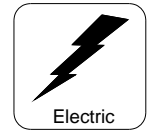

# Bentonite Mud Mixer Model M-375E

**Surface to Surface Inc.**



**Features and Benefits      M-375E Mixer**

The M-375E was the original Sam-Series Mixer, designed and manufactured primarily for the mini size drill rigs as an alternative to using plain water. Powered by a 10HP Teco/Westinghouse electric motor, driving a 3" centrifugal pump makes effective use of the proprietary StS mixing system. This Bentonite mud mixer is capable of providing 375 gallons of full yield mud to your drill rig in less than 5 mins. The compact unit can be transported to the job site in a standard 8' pickup box.

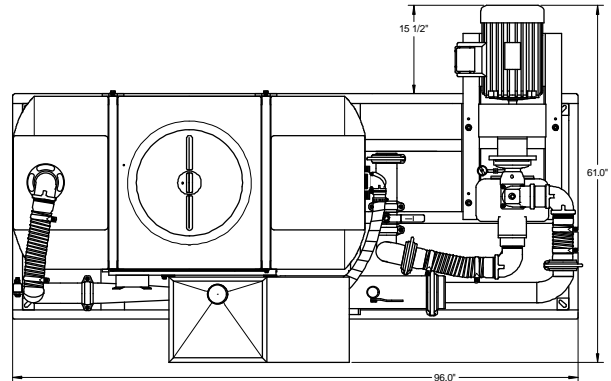

**Specifications**

**M-375 Mixer**

Dimensions	61" W x 96" L x 65" H
Weight	1300 Lbs
Hopper Height	37 1/2" High
Mixing System	3" Proprietary StS Mixing System
Mixing Tank	375 gal Polyethylene
Skid Frame	4" Steel channel, welded
Motor	10 HP Teco 360V/460V
Pump	3" Cast iron centrifugal trash pump
Pump / Motor Connection	Bearing Block to Lovejoy® Coupler
Drill Fluid Outlet	1 1/2" NPT with Full Flow Ball Valve
Pipe Couplers	Bolt & Snap-groove type
Pressure Wand	Hopper maintenance wand
Tank Drain	Bottom tank drain supplied

**Benefits**

- Small space saving footprint.
- Light weight for easy transportation.
- Waist high hopper reduces back strain.
- Fast & efficient ( 5 min. mixing ).
- Minimal maintenance required.
- Built tough for the construction trade.
- Industrial rated for longer service life.
- Rugged & repairable for extended service life.
- Large bearings & oversized coupler (service life)
- Large volume discharge
- Fast cold weather draining of system.
- Removal of blockages caused by additive.
- Fast cold weather draining.

Optional bolt on lifting bale available

Also available in Gasoline (M-375), Hydraulic (M-375H), and Diesel (M-375D) models.

\*\*\* All Specifications Subject to Change Without Notice \*\*\*

Check our website for the latest products and specifications  
**[www.stsmixers.com](http://www.stsmixers.com)**

**Surface to Surface Inc.**

5150 Forest Road, R.R.#3, Watford, Ontario, N0M 2S0  
Tel: 1-800-567-0978

11/04/11