



Bentonite Mud Mixer Model M-375D

Surface to Surface Inc.



Features and Benefits M-375D Mixer

The M-375D was the original Sam-Series Mixer, designed and manufactured primarily for the mini size drill rigs as an alternative to using plain water. Powered by a 9 hp air-cooled diesel engine, driving a 3" centrifugal pump makes effective use of the proprietary StS mixing system. This Bentonite mud mixer is capable of providing 375 gallons of full yield mud to your drill rig in less than 5 mins. The compact unit can be transported to the job site with ease.

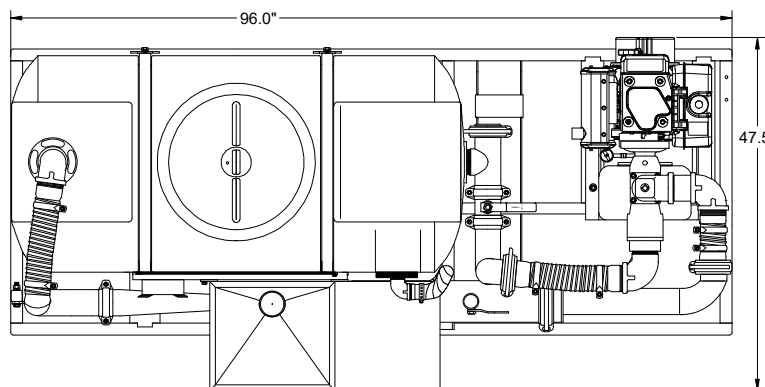

Specifications

- Dimensions
- Weight
- Hopper Height
- Mixing System
- Mixing Tank
- Skid Frame
- Engine
- Pump
- Pump Coupling
- Drill Fluid Outlet
- Pipe Couplers
- Pressure Wand

M-375D Mixer

- 47.5" W x 96" L x 70" H
- 1000 Lbs
- 38" High
- 3" Proprietary StS Mixing System
- 375 us gal Polyethylene
- Formed 3/16" Welded Steel
- 9.0 hp air-cooled, manual / 12V start
- 3" Cast iron centrifugal trash pump
- Direct coupled engine & pump
- 1 1/2" NPT with Full Flow Ball Valve
- Bolt & Snap-groove type
- Hopper maintenance wand

Benefits

- Small space saving footprint.
- Light weight for easy transportation.
- Waist high hopper reduces back strain.
- Fast & efficient (5 min. mixing).
- Minimal maintenance required.
- Built tough for the construction trade.
- Industrial rated for longer service life.
- Rugged & repairable for extended service life.
- No expensive couplers or inserts to replace.
- Large volume discharge
- Fast cold weather draining of system.
- Removal of blockages caused by additive.

Optional bolt on lifting bale (empty) available
Also available in Gasoline (M-375G) Electric (M-375E) Hydraulic (M-375H) models.

*** All Specifications Subject to Change Without Notice ***
Check our website for the latest products and specifications
www.stsmixers.com

Surface to Surface Inc.
5150 Forest Road, R.R.#3, Watford, Ontario, N0M 2S0
Tel: 1-800-567-0978

03/24/22