



Bentonite Mud Mixer Model M-500

Surface to Surface Inc.



Features and Benefits M-500 Mixer

The M-500 is designed and manufactured primarily for the HDD mini size drill rigs and tunnelers, as an alternative to using plain water. Powered by a 10 hp air-cooled gasoline engine, driving a 3" centrifugal pump that makes effective use of the proprietary 4 point mixing system, making it fast and powerful. This Bentonite mud mixer is capable of providing 500 gallons of full yield mud to your drill rig in less time than the competition. This compact unit can be mounted in a truck or on a trailer and transported to the job site with ease.

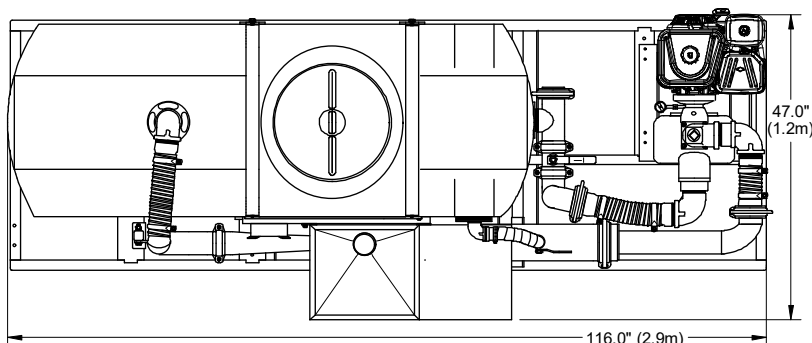

Specifications

Dimensions
Weight
Hopper Height
Mixing System
Mixing Tank
Skid Frame
Engine
Pump
Pump Coupling
Drill Fluid Outlet
Pipe Couplers
Pressure Wand
Tank Drain

M-500Mixer

47" W x 116" L x 70" H
1020 Lbs.
37" High
3" Proprietary StS Mixing System
500us gal Polyethylene
Formed steel, welded
10 hp air-cooled, manual start
3" Cast iron centrifugal trash pump
Direct coupled engine & pump
1 1/2" NPT with Full Flow Ball Valve
Bolt & Snap-groove type
Hopper maintenance wand
Bottom tank drain supplied

Benefits

Small space saving footprint.
Light weight for easy transportation.
Waist high hopper reduces back strain.
Fast & efficient .
Minimal maintenance required.
Built tough for the construction trade.
Industrial rated for longer service life.
Rugged & repairable for extended service life.
No expensive couplers or inserts to replace.
Large volume discharge
Fast cold weather draining of system.
Removal of blockages caused by additive.
Fast cold weather draining.Customer Installed

Also available in Electric (M-500E) Hydraulic (M-500H) Diesel (M-500D) models.

*** All Specifications Subject to Change Without Notice ***

Check our website for the latest products and specifications
www.stsmixers.com

Surface to Surface Inc.

5150 Forest Road, R.R.#3, Watford, Ontario, N0M 2S0
Tel: 1-800-567-0978

11/03/23