



Universal 4" Mixer Model M4-E

Surface to Surface Inc.



Features and Benefits M4-E Mixer

The M4-E universal mixer is designed around the time proven M series mixers of STS. Powered by a 20 hp Teco/Westinghouse electric motor, driving a 4" centrifugal pump, it makes effective use of the proprietary 4 point mixing system. The M4-E can be used as a new installation or retrofitted into an existing system of tank(s). Since the unit is connected by hose and not hard pipe, the placement of the mixer versus the tank(s) is less restricted and a configuration to suit the needs of the contractor are easier to achieve. The small size also makes it a portable, independent unit that is easier to transport from site to site.

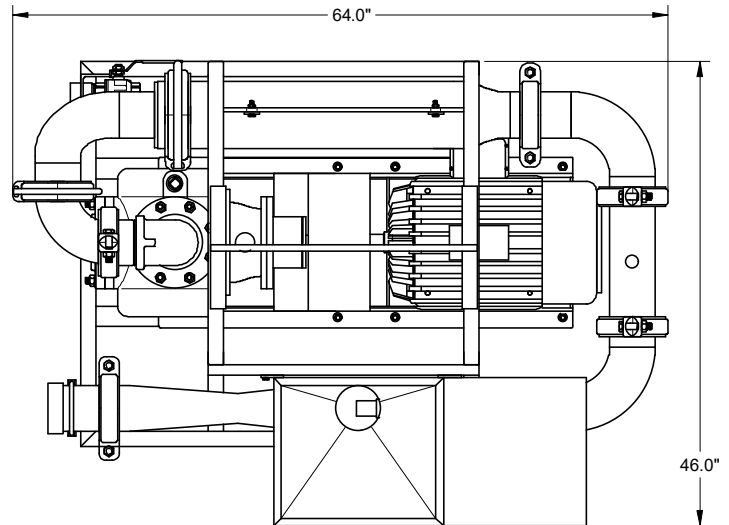

Specifications

M4-E Mixer

Dimensions	46" W x 64" L x 49" H
Weight	1275 Lbs
Hopper Height	38" High
Mixing System	4" Proprietary StS Mixing System
Flow Valves	Brass and Steel construction
Skid Frame	1½" steel tube with Lifting bale
Electric Motor	20 HP Teco / Westinghouse 230V/460V
Pump	4" Cast iron centrifugal trash pump
Pump Coupling	Bearing Block to Lovejoy® Coupler
Vacuum Port	2" NPT Inlet
Pipe Couplers	Bolt & Snap-groove type
Pressure Wand	Hopper maintenance wand
Internal Tank Jets	TurboMix™ Eductor Nozzles

Benefits

- Small space saving footprint.
- Light weight for easy transportation.
- Waist high hopper reduces back strain.
- Fast & efficient with high shearing ability.
- Withstand the abuse of daily operations
- Built tough for the construction trade.
- Industrial rated for longer service life.
- Rugged & repairable for extended service life.
- Large bearings & oversized coupler (service life)
- Draw Fluid into system without additional pump.
- Fast cold weather draining of system.
- Removal of blockages caused by additive.
- Fast and effective rolling and mixing action.

Also available in Diesel (M4-D), Gasoline (M4-G) or Hydraulic (M4-H) models.

*** All Specifications Subject to Change Without Notice ***

Check our website for the latest products and specifications

www.stsmixers.com

Surface to Surface Inc.

5150 Forest Road, R.R.#3, Watford, Ontario, N0M 2S0
Tel: 1-800-567-0978

03/03/11