

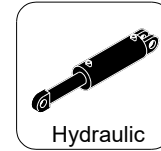

# Universal 3" Mixer Model M3-H

*Surface to Surface Inc.*



## Features and Benefits M3-H Mixer

The M3-H universal mixer is designed around the time proven M series mixers of STS. Powered by the customer's own power source. A 10gpm. hydraulic motor drives a 3" centrifugal pump, making effective use of the proprietary 4 point mixing system. The M3-H can be used as a new installation or retrofitted into an existing system of tank(s). Since the unit is connected by hoses and not hard pipe, the placement of the mixer versus the tank(s) is less restricted and a configuration to suit the needs of the contractor is easier to achieve. The small size also makes it a portable, independent unit that is easier to transport from site to site.

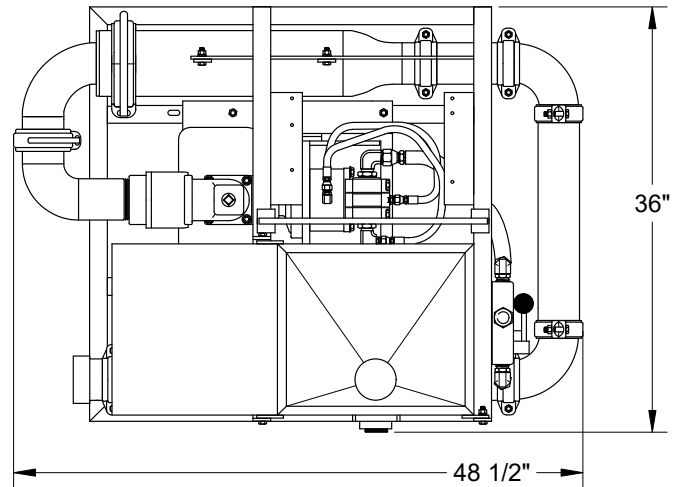

## Specifications

## M3-H Mixer

Dimensions	36" W x 48 1/2" L x 35 1/2" H
Weight	490 Lbs
Hopper Height	35-1/2" High
Mixing System	3" Proprietary StS Mixing System
Flow Valves	Brass and Steel construction
Skid Frame	1 1/2" steel tube with fork pockets
Hydraulic gear motor	Requires 10gpm. @ 1800psi
Hydraulic valve	Variable speed controler
Hydraulic system	Open loop circuit
Pump	3" Cast iron centrifugal trash pump
Pump Coupling	Hyd. Motor direct to Bearing Block
Vacuum Port	1 1/2" NPT Inlet
Pipe Couplers	Bolt & Snap-groove type
Pressure Wand	Hopper maintenance wand
Internal Jet Guns	TurboMix™ Eductor Nozzles

## Benefits

- Small space saving footprint.
- Light weight for easy transportation.
- Waist high hopper reduces back strain.
- Fast & efficient with high shearing ability.
- Withstand the abuse of daily operations
- Built tough for the construction trade.
- Use your own power source, no fumes in truck body
- Allow mixing at various speeds.
- Simple, field repairable, less maintenance
- Rugged & repairable for extended service life.
- No expensive couplers or inserts to replace.
- Draw Fluid into system without additional pump.
- Fast cold weather draining of system.
- Removal of blockages caused by additive.
- Fast and effective rolling and mixing action.

Also available in Gas (M3-G), Diesel (M3-D) or Electric (M3-E) models.

Check our website for the latest products and specifications  
[www.stsmixers.com](http://www.stsmixers.com)

**Surface to Surface Inc.**

5150 Forest Road, R.R.#3, Watford, Ontario, N0M 2S0  
 Tel: 1-800-567-0978

06/08/09