



Bentonite Mud Mixer Model M-1500

Surface to Surface Inc.



Features and Benefits M-1500 Mixer

The M-1500 was designed and manufactured as a dual tank system that allows the HDD contractor two methods of mixing their bentonite mud requirements. This system allows the operator to mix 750 gallons of full yield mud in less than eight (8) minutes, while holding 750 gallons of water reserve in the second tank for the next mix, or mix 1500 gallons of full yield mud in less than sixteen (16) minutes, in one large batch. The operator controls the two methods of mixing by changing the direction of flows through the piping connections using the manual operated full flow valves. The vacuum port located in the mixing tee has the ability to draw water from the second tank when being used as a reservoir and the drill fluid can then be sent to your drilling rig with-out the use of a second pump. This model has been a popular choice of HDD Contactors due to its small space saving footprint relative to its capacity. Other power drives available.

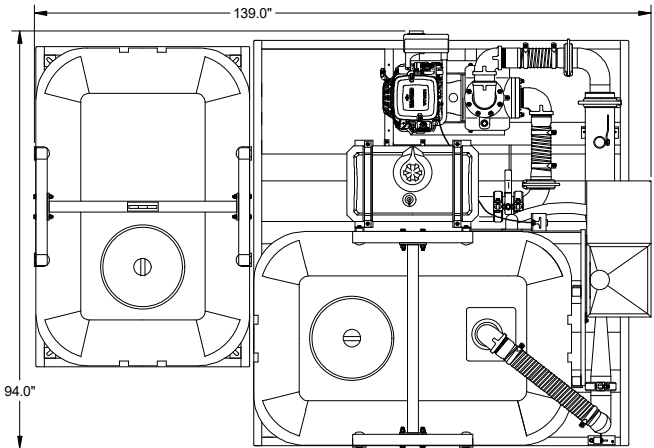

Specifications

Dimensions	M-1500 Mixer 94"W x 140"L x 77"H
Approx. Weight	2625 lbs
Hopper Height	39 inches high
Mixing System	4" Proprietary StS Mixing System
Mixing Tank (2)	750 gallon Roto-Mold Polyethylene
Skid frame (2)	5" Steel Channel, Welded
Gasoline Engine	18-23 hp Air Cooled Electric Start
Pump	4" Cast Iron Centrifugal Trash Pump
Pump Drive	Direct Coupled Engine to Pump
Fuel Tank	15 gal. Plastic Tank
Pipe Couplers	Bolt and Snap -Groove Type
Pressure Wand	Hopper Maintenance Wand
Tank Drain (2)	Bottom Tank Drains Supplied

Benefits

- Space saving design for its capacity.
- Excellent weight distribution
- Waist high hopper reduces back strain.
- Fast, efficient mixing time.
- Minimal maintenance required.
- Built for the rigors of the construction trade.
- Industrial rated for long service life.
- Rugged & Repairable for extended service life.
- No expensive couplers or inserts to replace.
- Provides a full day running on a fill up.
- Provide fast cold weather draining of system.
- Removal of blockages caused by additives.
- Provides fast cold weather tank drainage.

Also available in Diesel (M-1500D) - Hydraulic (M-1500H) – Electric (M-1500E) models.

*** All Specifications Subject to Change Without Notice ***

Check our website for the latest products and specifications
www.stsmixers.com

Surface to Surface Inc.

5150 Forest Road, R.R.#3, Watford, Ontario, N0M 2S0
Tel: 1-800-567-0978

03/29/22