

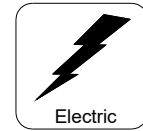

Surface to Surface Inc.
Dependable & efficient mixers

**Semi-Solids Solidification Unit
Model FL243-11-6E**



Surface to Surface Inc.

Features and Benefits: FL243-11-6E

The FL243 series processing unit (Patent #US10507443) was designed to efficiently mix a high slump material (slurry) with a minimal amount of a dry product, to create a by-product that has a low slump discharge. This by-product can now be handled as a "solid" material. Depending on the dry product used, characteristics of the "solid" by-product may lead to a secondary use or ease of disposal. The FL243 unit operates on a continuous process, not on a batch type process. This allows for larger output at days end. The unit is able to process approximately 86 -100 gpm., depending on the material characteristics.

The FL243 was designed for ease of set-up / teardown and can be operated by a single competent operator.

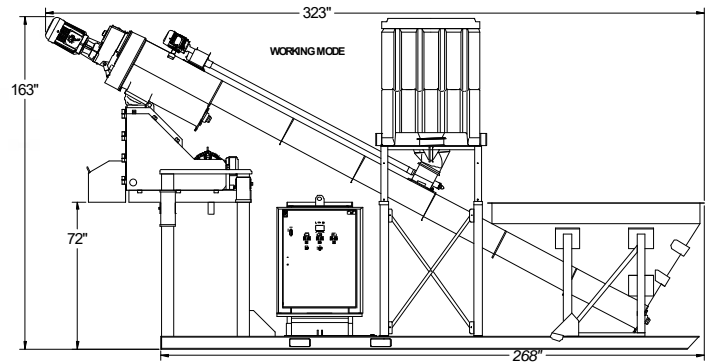

Specifications

FL243-11-6E Mixer

Dimensions	Transport Mode
Approx. Weight	Working Mode
Wet Feed Hopper Height	11135lbs. (5051Kg.)
Wet Feed Auger & Trough Skid Frame	72" (3m ³)
Electric Motors	11" OD x 3/8" Alloy Flighting & Trough
Dry Product Auger	6" Steel Beam, Welded
Flexible Rotary Mixing	Oversized, Fan Cooled Cast Iron
Rigid Sealed Tote	360V/460V
Single Belt Drive	2 5/8" OD Flighting, Closed Tube Auger
Ground Level Operation	Hardened Steel Flailing Chains
	Sloped Bottom Tote with Knife Valve
	Industrial Grade Double Sided Cogged Belt
	Control Panel & Daily Greasing Ground Level

Benefits

- 104" H x 336" L x 76" W
- 163" H x 323" L x 76" W
- Small sized equipment to load wet hopper.
- Large solids pass thru & extended wear.
- Built for the rigors of the construction trade.
- Industrial rated for longer service life.
- Able to handle a multitude of dry products.
- No prescreening of Sludge/Slurry required.
- Weatherproof storage /discharge of dry product.
- Positive drive, no slip, longer wear life.
- No Climbing to operate or maintain the unit.

*** All Specifications Subject to Change Without Notice***

Check our website for the latest products and specifications
www.stsmixers.com

Surface to Surface Inc.

5150 Forest Road, R.R.#3, Watford, Ontario, N0M 2S0
Tel: 1-800-567-0978

08/23/21