



Surface to Surface Inc.
Dependable & efficient mixers

Semi-Solids Solidification Unit Model FL243-11-6E

Surface to Surface Inc.

Features and Benefits: FL243-11-6E

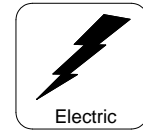

The FL243 series processing unit (Patent #US10507443) was designed to efficiently mix a high slump material (slurry) with a minimal amount of a dry product, to create a by-product that has a low slump discharge. This by-product can now be handled as a "solid" material. Depending on the dry product used, characteristics of the "solid" by-product may lend to a secondary use or ease of disposal. The FL243 unit operates on a continuous process and not on a batch type process. This allows for larger output at days end. The unit is able to process approximately 86 -100 gpm., depending on the material characteristics.

The FL243 was designed for ease of set-up / teardown and can be operated by a single competent operator.

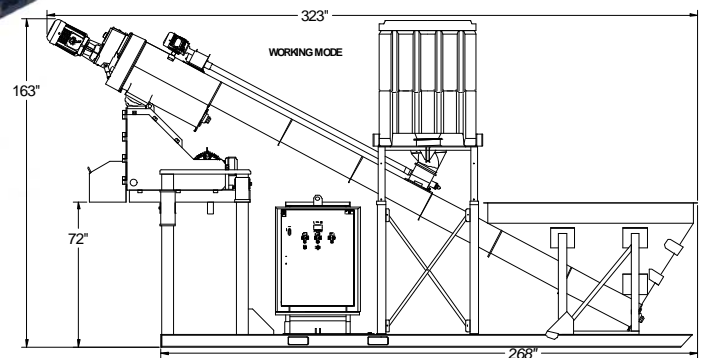

Specifications

FL243-11-6E Mixer

Benefits

Dimensions	Transport Mode	104" H x 336" L x 76" W
	Working Mode	163" H x 323" L x 76" W
Approx. Weight		
Wet Feed Hopper Height	7300lbs. (3311Kg.)	
Wet Feed Auger	72" (holds 3m ³)	
Skid Frame	11" OD x 3/8" AR400 Flighting	
Electric Motors	6" Steel Beam, Welded	
Dry Product Auger	Oversized, Fan Cooled Cast Iron 460V	
Flexible Rotary Mixing	2 5/8" OD Flighting, Closed Tube Auger	
Rigid Sealed Tote	Hardened Steel Flailing Chains	
Single Belt Drive	Sloped Bottom Tote with Knife Valve	
Ground Level Operation	Industrial Grade Double Sided Cogged Belt	
Options:	Control Panel & Daily Greasing Ground Level	

- Small sized equipment to load wet hopper.
- Large solids pass thru & extended wear.
- Built for the rigors of the construction trade.
- Industrial rated for longer service life.
- Able to handle a multitude of dry products.
- No prescreening of Sludge/Slurry required.
- Weatherproof storage /discharge of dry product.
- Positive drive, no slip, longer wear life.
- No Climbing to operate or maintain the unit.

- 4" OD Dry Product Auger (Allows for a larger volume of a dry product to be added)
- Vibrating Hopper Debris Screen "Grizzly Bars" (Stops rocks / debris from entering the hopper)
- 6" Pipe Hopper Inlet (allows for a secure hose connection from a pumping device)

Also available in Diesel / Hydraulic (FL243-11-6H) model.

*** All Specifications Subject to Change Without Notice ***

Check our website for the latest products and specifications
www.stsmixers.com

Surface to Surface Inc.

5150 Forest Road, R.R.#3, Watford, Ontario, N0M 2S0
Tel: 1-800-567-0978

05/08/20