



Universal 2" Mixer Model M2-G

Surface to Surface Inc.



Features and Benefits M2-G Mixer

The M2-G universal mixer is designed around the time proven M series mixers of STS. Powered by an 9 hp air-cooled gasoline engine, driving a 2" centrifugal pump, making effective use of the proprietary 4 point mixing system. The M2-G can be used as a new installation or retro fitted into an existing tank. Since the unit is connected by hoses and not hard pipes, the placement of the mixer to the tank is less restricted and a configuration to suit the needs of the contractor and available space, are easier to achieve. The small size also makes it a portable, independent unit that is easier to transport from site to site.

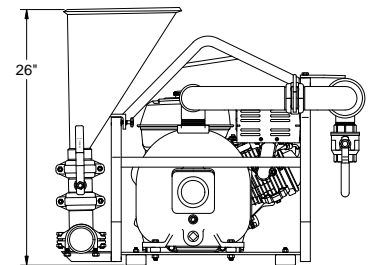
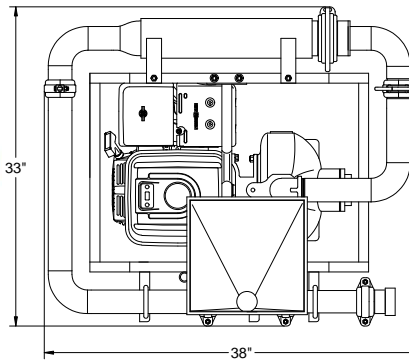

Specifications

- Dimensions
- Weight
- Hopper Height & Size
- Mixing System
- Flow Valves
- Skid Frame
- Engine
- Pump
- Pump Coupling
- Pipe Couplers
- Pressure Wand
- Internal Tank Jets(supplied)
- Mechanical Seal
- Replaceable Wear Plate

M2-G Mixer

- 33" W x 38" L x 26" H
- 260 Lbs
- 26" High Holds 1/2 of a bag
- 2" Proprietary StS Mixing System
- Brass and Steel construction
- 1 1/2" steel tube with lifting bale
- 9.0 hp air-cooled, manual start
- 2" Cast iron centrifugal trash pump
- Direct coupled engine & pump
- Bolt & Snap-groove type
- Hopper maintenance wand
- Eductor Nozzles (5-1 fluid output)
- Self Pressurizing Grease Seal
- Hardened plate ahead of Impeller

Benefits

- Small space saving footprint.
- Light weight for easy transportation.
- Low hopper height reduces back strain.
- Fast & efficient with high shearing ability.
- Withstand the abuse of daily operations
- Built tough for the construction trade.
- Robin / Subaru EX27 9HP for higher visc. drill fluids
- Gorman-Rupp 80 series
- No expensive couplers or inserts to replace.
- Fast cold weather draining of system.
- Removal of build-up caused by additive.
- Fast and effective rolling and mixing action.
- Greaseable seal for more rugged working conditions
- Less wear on internal pump parts and is replaceable.

With a 40 second viscosity, the M2 produces 90 gpm @ 36psi through the nozzle and 52 gpm @ 36psi to the tank internal jets (5-1 mixing equals 260 gpm of mixing / rolling action in tank) and a discharge rate of 80 gpm @ 36psi

Also available in Electric (M2-E) , Hydraulic (M2-H) or Diesel (M2-D) models.

Check our website for the latest products and specifications
www.stsmixers.com

Surface to Surface Inc.

5150 Forest Road, R.R.#3, Watford, Ontario, N0M 2S0
Tel: 1-800-567-0978

05/12/10