



Universal 2" Mixer Model M2-D

Surface to Surface Inc.



Features and Benefits M2-D Mixer

The M2-D universal mixer is designed around the time proven M series mixers of STS. Powered by a 9 hp air-cooled diesel engine, driving a 2" centrifugal pump, making effective use of the proprietary 4 point mixing system. The M2-D can be used as a new installation or retro fitted into an existing tank. Since the unit is connected by hoses and not hard pipes, the placement of the mixer to the tank is less restricted and a configuration to suit the needs of the contractor and available space, are easier to achieve. The small size also makes it a portable, independent unit that is easier to transport from site to site.

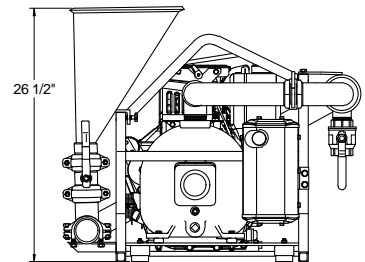
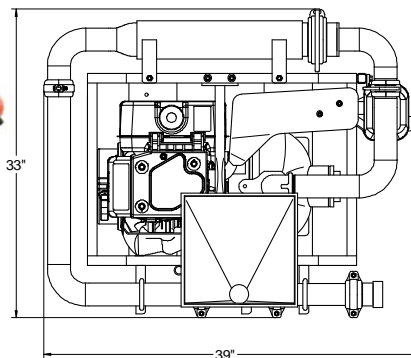

Specifications

Dimensions
 Weight
 Hopper Height & Size
 Mixing System
 Flow Valves
 Skid Frame
 Engine
 Pump
 Pump Coupling
 Pipe Couplers
 Pressure Wand
 Internal Tank Jets(supplied)
 Mechanical Seal
 Replaceable Wear Plate

M2-D Mixer

33" W x 39" L x 26 1/2" H
 350 Lbs
 26 1/2" High Holds 1/2 of a bag
 2" Proprietary StS Mixing System
 Brass and Steel construction
 1 1/2" steel tube with lifting bale
 9.0 hp air-cooled, man/ elect start
 2" Cast iron centrifugal trash pump
 Direct coupled engine & pump
 Bolt & Snap-groove type
 Hopper maintenance wand
 Eductor Nozzles (5-1 fluid output)
 Self-Pressurizing Grease Seal
 Hardened plate ahead of Impeller

Benefits

Small space saving footprint.
 Light weight for easy transportation.
 Low hopper height reduces back strain.
 Fast & efficient with high shearing ability.
 Withstand the abuse of daily operations
 Built tough for the construction trade.
 Industrial rated for longer service life
 Gorman-Rupp 80 series
 No expensive couplers or inserts to replace.
 Fast cold weather draining of system.
 Removal of build-up caused by additive.
 Fast and effective rolling and mixing action.
 Greaseable seal for more rugged working conditions
 Less wear on internal pump parts and is replaceable.

With a 40 second viscosity, the M2 produces 90 gpm @ 36psi through the nozzle and 52 gpm @ 36psi to the tank internal jets (5-1 mixing equals 260 gpm of mixing / rolling action in tank) and a discharge rate of 80 gpm @ 36psi

Also available in Electric (M2-E) , Hydraulic (M2-H) or Gasoline (M2-G) models.

Check our website for the latest products and specifications
www.stsmixers.com

Surface to Surface Inc.

5150 Forest Road, R.R.#3, Watford, Ontario, N0M 2S0
Tel: 1-800-567-0978

03/06/12