

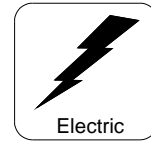

Universal 3" Mixer Model M3-E

Surface to Surface Inc.



Features and Benefits M3-E Mixer

The M3-E universal mixer is designed around the time proven M series mixers of STS. Powered by a 10HP Teco/Westinghouse electric motor, driving a 3" centrifugal pump, making effective use of the patented 4 point mixing system. The M3-E can be used as a new installation or retrofitted into an existing system of tank(s). Since the unit is connected by hoses and not hard pipe, the placement of the mixer verses the tank(s) is less restricted and a configuration to suit the needs of the contractor is easier to achieve. The small size also makes it a portable, independent unit that is easier to transport from site to site.

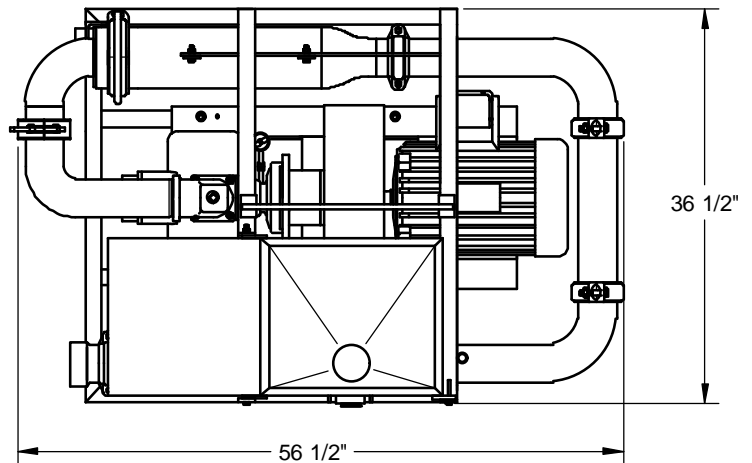

Specifications

M3-E Mixer

Dimensions	361/2" W x 561/2" L x 351/2" H
Weight	700 Lbs
Hopper Height	43 1/2" High
Mixing System	3" Patented StS Mixing System
Flow Valves	Brass and Steel construction
Skid Frame	1 1/2" steel tube with fork pockets
Motor	10 HP Teco 230V/460V 60Hz
Pump	3" Cast iron centrifugal trash pump
Pump / Motor Connection	Bearing Block to Lovejoy® Coupler
Vacuum Port	1 1/2" NPT Inlet
Pipe Couplers	Bolt & Snap-groove type
Pressure Wand	Hopper maintenance wand
Internal Jet Guns	TurboMix™ Eductor Nozzles

Benefits

- Small space saving footprint.
- Light weight for easy transportation.
- Waist high hopper reduces back strain.
- Fast & efficient with high shearing ability.
- Withstand the abuse of daily operations
- Built tough for the construction trade.
- Industrial rated for longer service life.
- Rugged & repairable for extended service life.
- Large bearings & oversized coupler (service life)
- Draw Fluid into system without additional pump.
- Fast cold weather draining of system.
- Removal of blockages caused by additive.
- Fast and effective rolling and mixing action.

Also available in Gas (M3-G), Diesel (M3-D) or Hydraulic (M3-H) models.

*** All Specifications Subject to Change Without Notice ***

Check our website for the latest products and specifications
www.stsmixers.com

Surface to Surface Inc.

5150 Forest Road, R.R.#3, Watford, Ontario, N0M 2S0
Tel: 1-800-567-0978

05/03/12