



Bentonite Mud Mixer Model M-300D

Surface to Surface Inc.



Features and Benefits M-300D Mixer

The M-300D was the original Sam-Series Mixer, designed and manufactured primarily for the mini size drill rigs as an alternative to using plain water. Powered by a 9 hp air-cooled diesel engine, driving a 3" centrifugal pump makes effective use of the patented StS mixing system. This Bentonite mud mixer is capable of providing 300 gallons of full yield mud to your drill rig in less than 5 mins. The compact unit can be transported to the job site in a standard 8'

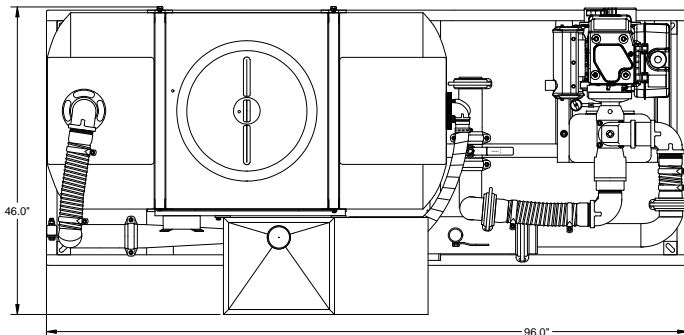

Specifications

Dimensions
Weight
Hopper Height
Mixing System
Mixing Tank
Skid Frame
Engine
Pump
Pump Coupling
Drill Fluid Outlet
Pipe Couplers
Pressure Wand
Tank Drain

M-300D Mixer

46" W x 96" L x 61" H
1124 Lbs
34-1/2" High
3" Patented StS Mixing System
300 gal Polyethylene
4" Steel channel, welded
9.0 hp air-cooled, manual start
3" Cast iron centrifugal trash pump
Direct coupled engine & pump
1 1/2" NPT with Full Flow Ball Valve
Bolt & Snap-groove type
Hopper maintenance wand
Bottom tank drain supplied

Benefits

Small space saving footprint.
Light weight for easy transportation.
Waist high hopper reduces back strain.
Fast & efficient (5 min. mixing).
Minimal maintenance required.
Built tough for the construction trade.
Industrial rated for longer service life.
Rugged & repairable for extended service life.
No expensive couplers or inserts to replace.
Large volume discharge
Fast cold weather draining of system.
Removal of blockages caused by additive.
Fast cold weather draining.

Optional bolt on lifting bale available

Also available in Gasoline (M-300G) Electric (M-300E) Hydraulic (M-300H) models.

*** All Specifications Subject to Change Without Notice ***

Check our website for the latest products and specifications
www.stsmixers.com

Surface to Surface Inc.

5150 Forest Road, R.R.#3, Watford, Ontario, N0M 2S0
Tel: 1-800-567-0978

12/21/09